



2000Xc Series Actuator

Operating Manual

Branson Ultrasonics Corp.
120 Park Ridge Road
Brookfield, CT 06804
(203) 796-0400
<http://www.bransonultrasonics.com>

BRANSON

Manual Change Information

At Branson, we strive to maintain our position as the leader in ultrasonics plastics joining, metal welding, cleaning and related technologies by continually improving our circuits and components in our equipment. These improvements are incorporated as soon as they are developed and thoroughly tested.

Information concerning any improvements will be added to the appropriate technical documentation at its next revision and printing. Therefore, when requesting service assistance for specific units, note the Revision information found on this document, and refer to the printing date which appears in this page.

Copyright and Trademark Notice

Copyright © 2025 Branson Ultrasonics Corporation. All rights reserved. Contents of this publication may not be reproduced in any form without the written permission of Branson Ultrasonics Corporation.

Mylar is a registered trademark of DuPont Teijin Films.

Loctite is a registered trademark of Loctite Corporation.

WD-40 is a registered trademark of WD-40 Company.

Windows 7, Windows Vista, and Windows XP are registered trademarks of Microsoft Corporation

Other trademarks and service marks mentioned herein are held by their respective owners.

Foreword

Congratulations on your choice of a Branson Ultrasonics Corporation system!

The Branson 2000Xc Series system is process equipment for the joining of plastic parts using ultrasonic energy. It is the newest generation of product using this sophisticated technology for a variety of customer applications. This Operating Manual is part of the documentation set for this system, and should be kept with the equipment.

Thank you for choosing Branson!

Introduction

This manual is arranged into several structured chapters which will help you find the information you may need to know to safely handle, install, set up, program, operate, and/or maintain this product. Please refer to the [Table of Contents](#) and/or the [Index](#) of this manual to find the information you may be looking for. In the event you require additional assistance or information, please contact our Product Support department (see [1.4 How to Contact Branson](#) for information on how to contact them) or your local Branson representative.

Table of Contents

Chapter 1: Safety and Support

1.1	Safety Requirements and Warnings	2
1.2	General Precautions	5
1.3	Warranty	7
1.4	How to Contact Branson	8
1.5	Returning Equipment for Repair	9
1.6	Obtaining Replacement Parts	12

Chapter 2: Introduction

2.1	Models Covered	14
2.2	Compatibility with Branson Products	19
2.3	Features of the System	20
2.4	Power Supply Front Panel Controls	23
2.5	Actuator Controls and Indicators	24
2.6	Glossary	25
2.7	21 CFR Part 11 Capability	34

Chapter 3: Delivery and Handling

3.1	Shipping and Handling	36
3.2	Receiving	37
3.3	Unpacking	38
3.4	Returning Equipment	39

Chapter 4: Technical Specifications

4.1	Technical Specifications	42
4.2	Physical Description	45

Chapter 5: Installation and Setup

5.1	About Installation	50
5.2	Handling and Unpacking	51
5.3	Take Inventory of Small Parts	54
5.4	Installation Requirements	56
5.5	Installation Steps	66
5.6	Guards and Safety Equipment	81
5.7	Rack Mount Installation	82
5.8	Assemble the Acoustic Stack	84
5.9	Mounting the Fixture on the Base Hardware and mounting holes	92
5.10	Testing the Installation	94
5.11	Still Need Help?	95

Chapter 6: Actuator Operation

6.1	Actuator Controls	98
6.2	Initial Actuator Settings	99
6.3	Operating the Actuator	104
6.4	Safety Circuit Alarms	105

Chapter 7: Maintenance

7.1	Calibration	108
7.2	Periodic and Preventive Maintenance.	109
7.3	Parts Lists	114

Appendix A: Manual Revisions

A.1	Manual Revisions	120
-----	----------------------------	-----

List of Figures

Chapter 1: Safety and Support

Figure 1.1	Safety label on the rear of the 2000Xc Power Supply	3
Figure 1.2	Caution label on the 2000Xc Series Actuator for the factory air supply	3
Figure 1.3	Safety label shown on the rear of the 2000Xc Series Actuator	3
Figure 1.4	Connector label on the 2000Xc Series Actuator	3
Figure 1.5	Safety Labels on front of the 2000Xc Series Actuator	4

Chapter 2: Introduction

Figure 2.1	Left Side View of the 2000Xc Series Actuator.	14
Figure 2.2	Left Side View of the 2000Xc Micro Actuator	15
Figure 2.3	2000Xc Power Supply Front Panel Display after Power-Up.	23

Chapter 3: Delivery and Handling

Chapter 4: Technical Specifications

Figure 4.1	2000Xc Series Actuator Pneumatic System	47
------------	---	----

Chapter 5: Installation and Setup

Figure 5.1	Linear Encoder.	51
Figure 5.2	Unpacking the Stand (Actuator on a Base)	52
Figure 5.3	Ultrasonic Converter (J-Type for Stand-Alone Use) and Booster.	53
Figure 5.4	Power Supply Dimensional Drawing	57
Figure 5.5	2000Xc Series Actuator Dimensional Drawing Hub	58
Figure 5.6	Block Wiring Diagram	62
Figure 5.7	Base Mounting Centers	67
Figure 5.8	Rear view of Actuator, showing Mounting Surface, Bolt and Guide Pin locations.	69
Figure 5.9	Electrical Connections from Power Supply to a 2000Xc Series Actuator.	72
Figure 5.10	Start Switch Connection Codes (CE Actuator)	74
Figure 5.11	User I/O Cable Identification and Wire Color Diagram.	76
Figure 5.12	International Harmonized Line Cord Color Code	79
Figure 5.13	Actuator Emergency Stop Button	81
Figure 5.14	Detail of Rack Mount Handle Kit Assembly.	82
Figure 5.15	Assembling the 20 kHz Acoustic Stack	87
Figure 5.16	Connecting Tip to Horn	88
Figure 5.17	Installing a 20 kHz Stack in 2000Xc AEC Actuator	89
Figure 5.18	Installing a 40 kHz Stack in 2000Xc AEC Actuator	90
Figure 5.19	Installing a 40 kHz Stack in 2000Xc Micro Actuator	90
Figure 5.20	Mounting Holes on Base	92
Figure 5.21	Front Panel Display.	94

Chapter 6: Actuator Operation

Chapter 7: Maintenance

Appendix A: Manual Revisions

Figure A.1	Location of the information Label in the 2000Xc Actuator	120
------------	--	-----

List of Tables

Chapter 1: Safety and Support

Table 1.1	Branson Contacts	11
-----------	----------------------------	----

Chapter 2: Introduction

Table 2.1	2000Xc Series Actuator Compatibility with Branson Converters	19
Table 2.2	2000Xc Power Supply Front Panel Display after Power-Up	23
Table 2.3	Glossary	25

Chapter 3: Delivery and Handling

Table 3.1	Environmental Specifications	36
Table 3.2	Receiving	37
Table 3.3	Unpacking Procedure	38

Chapter 4: Technical Specifications

Table 4.1	Environmental Specifications	42
Table 4.2	Maximum Welding Force (at 100 psig and 4.0" stroke) For 2000Xc AEC Actuator	43
Table 4.3	Dynamic Trigger Force For 2000Xc AEC Actuator	43
Table 4.4	Dynamic Follow-Through For 2000Xc AEC Actuator	43
Table 4.5	Maximum Traverse Speed (application dependant) For 2000Xc AEC Actuator	44
Table 4.6	Description of Controls on Base	45
Table 4.7	2000Xc Series Actuator Pneumatic System	48

Chapter 5: Installation and Setup

Table 5.1	Small Parts included (=x) with Power Supply and/or Actuator Assemblies	54
Table 5.2	List of Cables	55
Table 5.3	Environmental Specifications	63
Table 5.4	Cubic Feet of air per minute per inch of stroke length (each direction)	65
Table 5.5	User I/O Cable Pin Assignments	77
Table 5.6	Input / Output Features	79
Table 5.7	User I/O DIP Switch Functions	80
Table 5.8	Rack Mount Installation	82
Table 5.9	Tools, Grease and Mylar Washers	84
Table 5.10	For a 20 kHz System	85
Table 5.11	For a 30 kHz System	85
Table 5.12	For a 40 kHz System	86
Table 5.13	Stud Torque Values	87
Table 5.14	Tip to Horn Torque Specifications	88

Chapter 6: Actuator Operation

Table 6.1	To adjust Mechanical Stop of 2000Xc AEC Actuator	101
Table 6.2	To adjust Mechanical Stop of 2000Xc Micro Actuator	102
Table 6.3	Operating the Actuator	104

Chapter 7: Maintenance

Table 7.1	Routine Component Replacement	112
Table 7.2	Accessories List for 2000Xc Series Actuator	114

Appendix A: Manual Revisions

Table A.1	Manual revisions	120
-----------	----------------------------	-----

Chapter 1: Safety and Support



1.1	Safety Requirements and Warnings	2
1.2	General Precautions	5
1.3	Warranty	7
1.4	How to Contact Branson	8
1.5	Returning Equipment for Repair	9
1.6	Obtaining Replacement Parts	12

1.1 Safety Requirements and Warnings

This chapter contains an explanation of the different Safety Notice symbols and icons found both in this manual and on the product itself and provides additional safety information for ultrasonic welding. This chapter also describes how to contact Branson for assistance.

1.1.1 Symbols Found in this Manual

These symbols used throughout this manual warrant special attention:

WARNING	Indicates a possible danger
	If these risks are not avoided, death or severe injury might result.
CAUTION	Indicates a possible danger
	If these risks are not avoided, slight or minor injury might result.
NOTICE	Indicates a possible damaging situation
	If this situation is not avoided, the system or something in its vicinity might get damaged. Application types and other important or useful information are emphasized.

1.1.2 Symbols Found on the Product

Familiar graphic warning symbols are used to alert the user to items of concern or hazard. The following warning symbols appear on the 2000Xc Series Actuator and Power Supply.

Figure 1.1 Safety label on the rear of the 2000Xc Power Supply

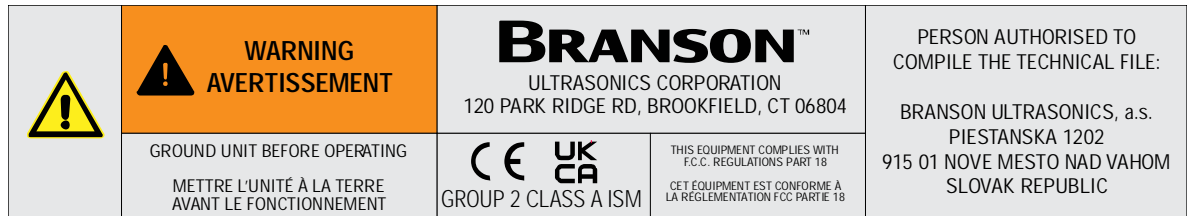

Figure 1.2 Caution label on the 2000Xc Series Actuator for the factory air supply



Figure 1.3 Safety label shown on the rear of the 2000Xc Series Actuator



Figure 1.4 Connector label on the 2000Xc Series Actuator

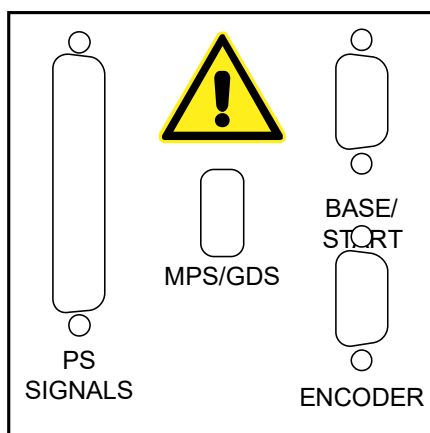

1.4.1 Connector Label of 2000Xc AEC Actuator

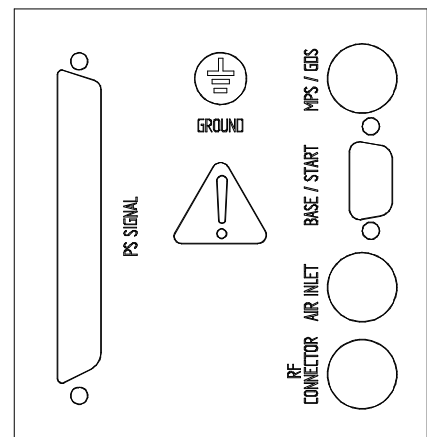

1.4.2 Connector Label of 2000Xc Micro Actuator

Figure 1.5 Safety Labels on front of the 2000Xc Series Actuator



Table 1.1 Safety Label on the Front of the Actuator



Icon	Description
<p>High Voltage Hazard</p> 	<p>Disconnect power before servicing.</p>
<p>Flying Debris and Loud Noise Hazards</p> 	<p>Eye and ear protection must be worn.</p>
<p>Burn Hazard</p> 	<p>Hot surfaces. Do not touch the tooling.</p>

Figure 1.6 Safety Label in the Actuator



1.2 General Precautions

Take the following precautions before servicing the power supply:

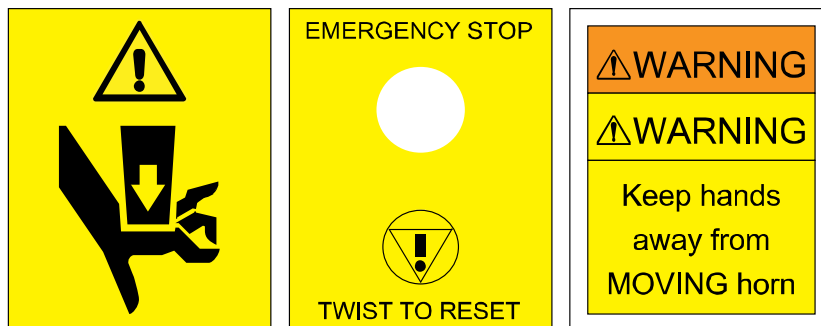
- To prevent the possibility of an electrical shock, always plug the power supply into a grounded power source
- To prevent the possibility of an electrical shock, ground the power supply by securing an 8 gauge grounded conductor to the ground screw located next to the air outlet
- Power supplies produce high voltage. Before working on the power supply assembly, do the following:
Turn off the power supply;
Unplug main power; and
Allow at least 5 minutes for capacitors to discharge
- High voltage is present in the power supply. Do not operate with the cover removed
- High line voltages exist in the ultrasonic power supply assembly. Common points are tied to circuit reference, not chassis ground. Therefore, use only non-grounded, battery-powered multimeters when testing the power supply assembly. Using other types of test equipment can present a shock hazard
- Keep hands from under the horn. Down force (pressure) and ultrasonic vibrations can cause injury
- Do not cycle the welding system if either the RF cable or converter is disconnected
- When using larger horns, avoid situations where fingers could be pinched between the horn and the fixture
- Ensure power supply installation is performed by qualified personnel and in accordance with local standards and regulations
- In normal operation, bearing seals will retain an adequate amount of grease for safe bearing operation. Bearing can leak but contains enough grease for the life of the bearing. Removing and running without grease will void the warranty. For more information contact product support

CAUTION	
	<p>Sound level and frequency of the noise emitted during the ultrasonic assembly process may depend upon a. type of application, b. size, shape and composition of the material being assembled, c. shape and material of the holding fixture, d. welder setup parameters and e. tool design.</p> <p>Some parts vibrate at an audible frequency during the process. Some or all of these factors may result in an uncomfortable noise being emitted during the process.</p> <p>In such cases operators may need to be provided with personal protective equipment. See 29 CFR (Code of Federal Regulations) 1910.95 Occupational Noise Exposure.</p>

1.2.1 Intended Use of the System

The 2000Xc Series Actuator and components are designed to be used as part of an ultrasonic welding system. These are designed for a wide variety of welding or processing applications.

NOTICE	
	If the equipment is used in a manner not specified by Branson, the protection provided by the equipment may be impaired. Indoor use only.

Branson Ultrasonics Corporation designs and manufactures machines giving the first priority to safety precautions, to allow customers to use the machines safely and effectively. Only trained operators should run the equipment. Untrained operators can misuse the equipment or ignore safety instructions that can result in personal injury or equipment damage. It is most essential that all operators pay attention to safety instructions when operating the equipment.

1.2.2 Emissions

Because of the various types of toxic or injurious gases that may be liberated during the welding based on the material being processed, sufficient ventilation should be provided to prevent a concentration of these gases in excess of 0.1 ppm. Check with your materials suppliers for recommended protection when processing their materials.

CAUTION	
	Processing of many materials, such as PVC, can be hazardous to an operator's health and could cause corrosion/damage to the equipment. Use proper ventilation and take protective measures.

1.2.3 Setting up the Workplace

Measures for setting up a workplace for safe operation of the ultrasonic welder are outlined in [Chapter 5: Installation and Setup](#).

1.2.4 Regulatory Compliance

This product meets electrical safety requirements and EMC (Electromagnetic Compliance) requirements for North America, Great Britain and the European Union.

1.3 Warranty

For warranty information please reference the warranty section of Terms and Conditions found at: www.emerson.com/branson-terms-conditions.

1.4 How to Contact Branson

Branson is here to help you. We appreciate your business and are interested in helping you successfully use our products. To contact Branson for help, use the following telephone numbers, or contact the field office nearest you (business hours from 8 a.m. to 4 p.m. Central and Eastern Time Zones):

- **North American Headquarters (all Departments):** (203) 796-0400
- **Parts Store (direct number):** (877) 330-0406
- **Repair department:** (877)-330-0405
- **For emergency after-hours service (5 p.m. – 8 a.m. EST):** (203) 796-0500 (US phone numbers only)

Tell the operator which product you have and which person or department you need ([Table 1.2](#)). If after hours, please leave a voice message with your name and return telephone number.

1.4.1 Before Calling Branson for Assistance

This manual provides information for troubleshooting and resolving problems that could occur with the equipment (see [Chapter 7: Maintenance](#)). If you still require assistance, Branson Product Support is here to help you. To help identify the problem, use the following questionnaire which lists the common questions you will be asked when you contact the Product Support department.

Before calling, determine the following information:

1. Your company name and location
2. Your return telephone number
3. Have your manual with you. If troubleshooting a problem, refer to [Chapter 7: Maintenance](#)
4. Know your equipment model and serial numbers (found on a gray data label on the units). Information about the horn (part number, gain, etc.) or other tooling may be etched into the tooling. Software- or firmware-based systems may provide a BOS or software version number, which may be required
5. What tooling (horn) and booster are being used?
6. What are the setup parameters and mode?
7. Is your equipment in an automated system? If so, what is supplying the “start” signal?
8. Describe the problem; provide as much detail as possible. For example, is the problem intermittent? How often does it occur? How long before it occurs if you are just powering up? If an error is occurring, which error (give error number or name)?
9. List the steps you have already taken
10. What is your application, including the materials being processed?
11. Have a list of service or spare parts you have on hand (tips, horns, etc.)
12. Notes:

1.5 Returning Equipment for Repair

Before sending equipment for repair, provide as much information with the equipment to help determine the problem with the system. Use the following page to record necessary information.

NOTICE	
	<p>To return equipment to Branson, you must first obtain an RGA number from a Branson representative, or the shipment may be delayed or refused.</p>

If you are returning equipment to Branson for repair, you must first call the Repair department to obtain a **Returned Goods Authorization (RGA)** number. (If you request it, the repair department will fax a Returned Goods Authorization form to fill out and return with your equipment).

Branson Repair Department, C/O Zuniga Logistics, LTD

12013 Sara Road, Killam Industrial Park

Laredo, Texas 78045 U.S.A.

Direct telephone number: (877) 330-0405

Fax number: (877) 330-0404

- Provide as much information as possible that will help identify the need for repair
- Carefully pack the equipment in original packing cartons
- Clearly label all shipping cartons with the RGA number on the outside of cartons as well as on your packing slip, along with the reason for return
- Return general repairs by any convenient method. Send priority repairs by air freight
- You must prepay the transportation charges FOB Laredo, Texas, U.S.A.

1.5.1 Get an RGA Number

RGA#

If you are returning equipment to Branson, please call the Repair Department to obtain a Returned Goods Authorization (RGA) number. (At your request, the Repair Department will fax an RGA form to fill out and return with the equipment).

1.5.2 Record Information About the Problem

Before sending equipment for repair, record the following information and send a copy of it with the equipment. This will greatly increase Branson's ability to address the problem.

1. Describe the problem; provide as much detail as possible. For example, is the problem intermittent? How often does it occur? How long before it occurs after powering up?

2. Is your equipment in an automated system?

3. If the problem is with an external signal, which signal?

4. If known, include plug/pin # (e.g., P29, pin #3) for that signal:

5. What are the Weld Parameters?

6. What is your application? (Type of weld, plastic material, etc.):

7. Name and phone number of the person most familiar with the problem:

Contact the Branson office prior to shipping the equipment.

For equipment not covered by warranty, to avoid delay, include a Purchase Order.

Send a copy of this page with the equipment being returned for repair.

1.5.3 Departments to Contact

Call your local Branson Representative, or contact Branson by calling and asking for the appropriate department, as indicated in [Table 1.2](#) below.

Table 1.2 Branson Contacts

What you need help with or information about	Whom to Call	At this Phone Number...
Information about new welding systems or components.	Your local Branson Rep or Branson Customer Service.	203-796-0400 Ext 384
Application and setup questions on the welding system.	Welding Applications Lab.	203-796-0400 Ext 368
Application assistance on the horns and tooling.	ATG Lab.	203-796-0400 Ext 495
Technical questions about the welding system.	Welding Product Support.	203-796-0400 Ext 355, 551
Technical questions about horns and tooling.	ATG Lab.	203-796-0400 Ext 495
Ordering new parts.	Parts Store.	877-330-0406
RGA's, request for repair, status of a repair.	Welding Repair Department.	877-330-0405
System automation/hookup information.	Product Support.	203-796-0400 Ext 355, 551

My Local Branson Representative's name is:

I can reach this representative at:

1.5.4 Pack and Ship the Equipment

- Carefully pack the system in original packing material to avoid shipping damage. Plainly show the RGA number on the outside of cartons as well as inside the carton along with the reason for return. Make a list of all components packed in the box. KEEP YOUR MANUAL.
- Return general repairs by any convenient method. Send priority repairs by air freight. Prepay the transportation charges FOB the repair site.

NOTICE	
	Items that are sent Freight Collect will be refused.

1.6 Obtaining Replacement Parts

You can reach Branson Parts Store at the following telephone numbers:

Branson Part Store

Direct telephone number: 877-330-0406

Fax number: 877-330-0404

Many parts can be shipped the same day if ordered before 2:30 p.m., Eastern time.

A parts list is found in [Chapter 7: Maintenance](#) of this manual, listing descriptions and EDP part numbers. If you need replacement parts, coordinate the following with your purchasing agent:

- Purchase order number
- Ship to information
- Bill to information
- Shipping instructions (air freight, truck, etc.)
- Any special instructions (for example, "Hold at the airport and call"). Be sure to give a name and phone number
- Contact name information

Chapter 2: Introduction

2.1	Models Covered	14
2.2	Compatibility with Branson Products	19
2.3	Features of the System	20
2.4	Power Supply Front Panel Controls	23
2.5	Actuator Controls and Indicators.	24
2.6	Glossary	25
2.7	21 CFR Part 11 Capability	34

2.1 Models Covered

This manual provides detailed instructions for installation, setup, operation, and maintenance of the 2000Xc Series Actuator.

The 2000Xc Series Actuator may be found in one of two configurations:

- An actuator on a column support, column and ergonomic base, also called a stand on base (as seen on [Figure 2.1](#))
- An actuator alone (not installed on a column support, and so on). These are often used in custom systems that provide a means of positioning the actuator

The figure below shows a Branson 2000Xc Series Actuator mounted on a column support which, in turn is mounted on a column, and is supported by the ergonomic base.

Figure 2.1 Left Side View of the 2000Xc Series Actuator

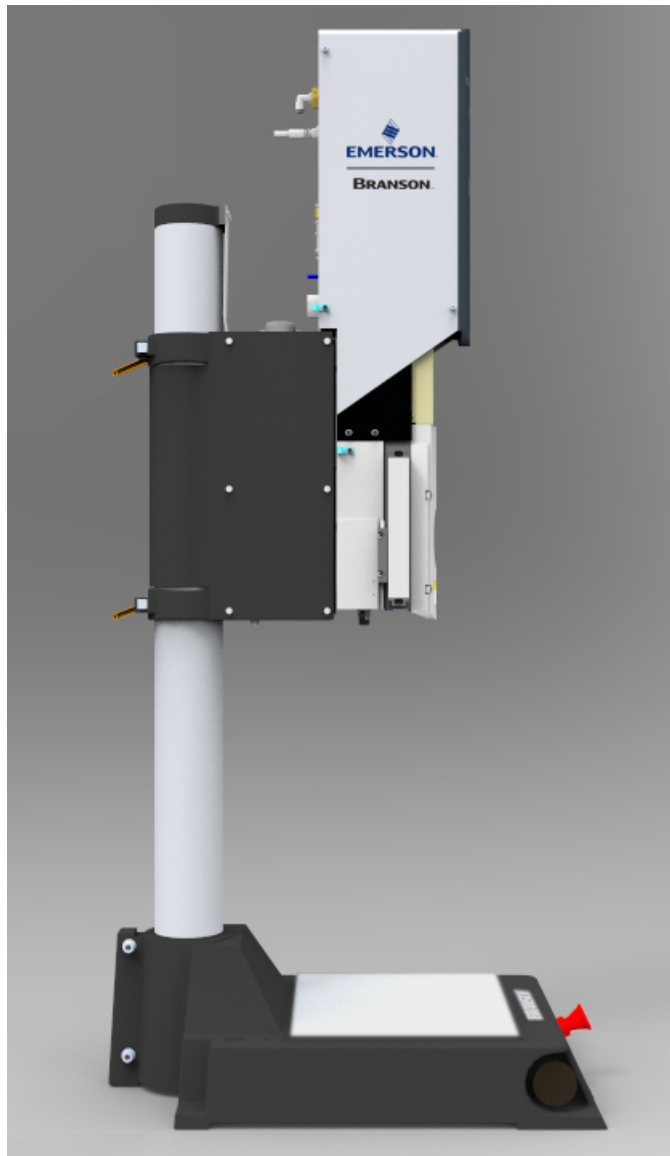
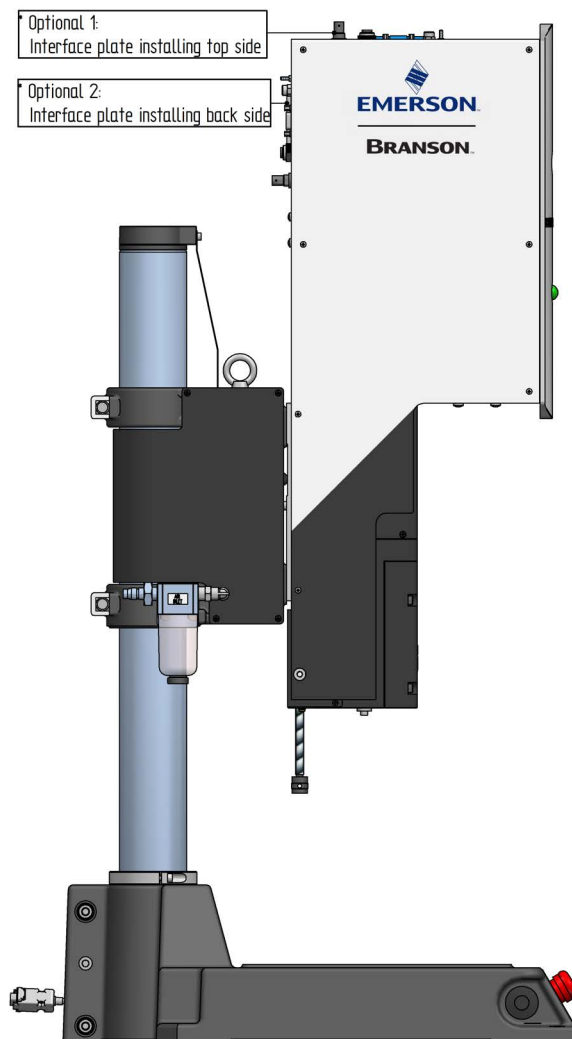

Figure 2.2 Left Side View of the 2000Xc Micro Actuator

2.1.1 Overview of the Welding system

The welding system consists of a power supply, an actuator, and a converter-booster-horn stack. The system can perform a variety of ultrasonic welding operations, including: inserting, staking, spot welding, swaging, degating, and continuous operations. It is designed for use in automated, semi-automated, and/or manual production systems.

2.1.2 Principle of Operation

Thermoplastic parts are welded ultrasonically by applying high-frequency vibrations to the parts being assembled. The vibrations, through surface and intermolecular friction, produce a sharp rise in temperature at the welding interface.

When the temperature is high enough to melt the plastic, there is a flow of material between the parts. When the vibrations stop, the material solidifies under pressure and a weld results.

Most plastics welders operate at a frequency above the range of human hearing (18 kHz) and are thus called ultrasonic.

2.1.3 The 2000Xc Power Supply

The power supply consists of an ultrasonic power supply module and a system controller. The ultrasonic power supply module converts conventional 50/60 Hz line current to 20 kHz, 30 kHz or 40 kHz electrical energy. The system controller monitors and controls the welding system.

The power supply is configured with a digital UPS. The digital supply has a library of up to 1000 locked presets which are accessible for various process parameter modifications that are unique to the power supply itself. These modifications can be named to reflect specific applications, and are loaded into memory prior to shipment from the Branson factory. The parameters of the individual presets can be modified by a Branson representative. Initially, one preset is set to factory default. They are accessed via an RS-232c link to the system controller.

The power supply provides the following features:

- **AutoTune with Memory (AT/M):** Allows the power supply to track and store the horn frequency of the last weld
- **Auto Seek:** Tracks and starts the horn on the correct frequency. It does this by running the horn at a low-level amplitude (5%) to find and lock on to the horn operating frequency
- **Line Regulation:** Maintains converter amplitude by regulating for variances in the line voltages
- **S-Beam Load Cell:** Provides an indication of the force on a part during a weld. This indication can be used to determine when to trigger ultrasonics and also to produce a force/distance graph of the operating cycle
- **Load Regulation:** Maintains converter amplitude over the full range of rated power
- **System Protection:** Protects the power supply by providing five levels of protection
 - Voltage
 - Current
 - Phase
 - Temperature
 - Power
- **Frequency Offset:** Provides for applying an external frequency offset to the operating frequency

2.1.4 The 2000Xc Series Actuator

The 2000Xc Series Actuator is a compact, rigid unit designed for use in manual, semi-automated, and automated ultrasonic welding systems. The actuator can be mounted directly on an I-beam (or similar machine frame), or it can be mounted on a column and base with start switches and used in a manual or benchtop system. The actuator is designed to be operated in an upright position, but is capable of running horizontally or inverted. If you are mounting your equipment in an inverted position, contact Branson for further recommendations. (See [1.4 How to Contact Branson](#)).

The 2000Xc Series Actuator requires a 2000Xc Series Actuator for power and control of the actuator's operation and to provide ultrasonic power to the converter in the actuator.

The 2000Xc Series Actuator is designed with full, built-in pneumatic controls, and mechanical controls. Operation of the 2000Xc Series Actuator is controlled by inputs to the 2000Xc Series Actuator.

S-Beam Load Cell and Dynamic Follow-Through

Many welding applications require force to be built up on the part before ultrasonic energy is activated. To achieve this, the actuator contains an S-Beam load cell, located between the air cylinder and the converter, which initiates (triggers) ultrasonics after a preset force is applied to the part. Dynamic follow-through maintains a consistent force on the part during the weld collapse. This system helps provide uniform weld quality.

The dynamic triggering and follow-through process operates as follows: upon activation of the operating cycle, the solenoid valve delivers regulated air to the upper portion of the cylinder, and exhausts air through the Downspeed control from the bottom of the cylinder, causing the horn to advance and contact the workpiece. When the load cell measurement of the force on the part indicates part contact, and the desired trigger force is reached, a signal is sent to the power supply, which then starts the weld cycle. At this time, the actuator locks into a cycle, timing begins, and the palm buttons can be released. As melting of the plastic occurs, the load cell dynamic follow through maintains consistent force on the part, ensuring smooth, efficient transmission of ultrasonic energy into the part.

The Carriage and Slide System

The 2000Xc Series Actuator's carriage is driven by a double-acting air cylinder. It is mounted on a linear ball-bearing slide. The slide system is based on eight sets of preloaded, permanently lubricated bearings and provides consistent, precise alignment of the horn, smooth linear motion, and long-term reliability.

Encoder

The encoder measures the distance the horn has traveled. Depending on the power supply settings, it can:

- Allow for distance welding in absolute and collapse modes
- Detect improper setup controls
- Monitor the distance data of the weld

The Pneumatic System

The pneumatic system included on the 2000Xc Series Actuator model is contained within the actuator's sheet-metal enclosure and consists of solenoid valves, an air cylinder, and a pressure regulator. The horn's rate of descent is adjusted by the Downspeed control in the power supply control panel. The rate of return is fixed. For information on setting the Downspeed control, see [2.5 Actuator Controls and Indicators](#).

2.1.5 The Ultrasonic Stack

Converter

The converter is mounted in the actuator as part of the ultrasonic stack. The ultrasonic electrical energy from the power supply is applied to the converter (sometimes called the transducer). This transforms the high frequency electrical oscillations into mechanical vibrations at the same frequency as the electrical oscillations. The heart of the converter are piezoelectric ceramic elements. When subjected to an alternating voltage, these elements alternately expand and contract, resulting in better than 90% conversion of electrical to mechanical energy.

Booster

Success in ultrasonic assembly depends on the right amplitude of movement at the horn face. Amplitude is a function of horn shape, which is largely determined by the size and form of the parts to be assembled. The booster can be used as a mechanical transformer to increase or decrease the amplitude of vibrations applied to the parts through the horn.

The booster is a resonant half-wave section of aluminum or titanium. It is mounted between the converter and the horn, as part of the ultrasonic stack. It also provides a clamping point for rigid stack mounting.

Boosters are designed to resonate at the same frequency as the converter with which they are used. Boosters are usually mounted at a nodal (minimum vibration) point of axial motion. This minimizes the loss of energy and prevents vibration from being transmitted into the actuator.

Horn

The horn is selected or designed for a specific application. Each horn is tuned typically as a half-wave section that applies the necessary force and vibration uniformly to the parts to be assembled. It transfers ultrasonic vibrations from the converter to the workpiece. The horn is mounted to the booster as part of the ultrasonic stack.

Depending on their profile, horns are referred to as stepped, conical, exponential, bar, or catenoidal. The shape of the horn determines the amplitude at the face of the horn. Depending on the application, horns can be made from titanium alloys, aluminum, or steel. Titanium alloys are the best materials for horn fabrication due to their high level of strength and low loss. Aluminum horns are usually chrome- or nickel-plated or hard-coated to reduce wear. Steel horns are for low amplitude requiring hardness, such as ultrasonic insertion applications.

2.2 Compatibility with Branson Products

The 2000Xc Series Actuator is designed to be used with the converters listed in the following table:

Table 2.1 2000Xc Series Actuator Compatibility with Branson Converters

Model	Converter
20 kHz/1250 W	CJ20
20 kHz/2500 W	
20 kHz/4000 W	
30 kHz/750 W	CJ30
30 kHz/1500 W	
40 kHz/400 W	4TJ
40 kHz/800 W	

2.3 Features of the System

Listed below are many features of the Branson 2000Xc Series ultrasonic welding system.

- **1 Millisecond Control and Sampling Rate:** This feature provides sampling and control of the weld process 1000 times each second
- **1000 Presets:** User-configurable setups that can be preset allowing you to simply recall a weld setup to start production
- **19" Rack Mount Enclosure:** Compatible with industry standard 19" rack enclosure systems
- **Adjust While Running:** The 2000Xc Series Actuator allows you to modify the weld parameters while the welder is running
- **Afterburst:** This feature allows you to set the system weld controls to turn the ultrasonics on after the weld and hold steps to release parts from the horn
- **Alarms, Process:** These are set values used for part quality monitoring
- **Amplitude Stepping:** A process controlled by the power supply. At a specified time, energy, peak power, distance, or by external signal you can change the amplitude during the weld to control the flow of plastic. This feature helps ensure part consistency, higher strength parts and control of flash
- **Automatic Preset Naming:** If you choose not to name your preset, the power supply will give it a name that describes the weld mode and main parameter setting
- **Autotuning:** Ensures that the welder is running at peak efficiency
- **Collapse Limits in the Collapse Mode:** Plus and minus Suspect and Reject limits can be set in the Collapse Mode
- **Control Limits:** With some power supply models, these secondary controls are used in conjunction with the main parameters of the weld. These user-programmed limits provide for adaptive control of the weld process
- **Cycle Aborts:** These are user programmed conditions (missing part and ground detect) at which the cycle is terminated. These can be used as safety limits to save wear and tear on the system and your tooling
- **Cycle Time and Date Stamp:** The power supply provides each cycle with a time and date stamp for production and quality control purposes
- **Digital Amplitude Setting:** This feature allows you to set the exact amplitude necessary for your application, affording increased range and setting repeatability over analog systems
- **Digital Horn Test Diagnostics:** In Test mode of the power supply, you can view the Horn Test results in digital form, using digital readouts and bar graphs on the power supply to give you the best picture of the stack's operation
- **Digital Tuning:** Means to tune the power supply for applications and horns at the extremes of the power supply capture range
- **Digital UPS:** The Digital UPS has programmable (through a digital interface from a system controller) features which allow true autotune and start ramp during set-up. Power supply presets can be customized
- **Downspeed:** Controls the rate of descent and impact on the part
- **Encoder:** Allows the power supply to monitor the distance the horn has travelled, enabling the use of distance functions
- **Energy Compensation:** Extend the weld time up to 50% greater than the weld time setting or to whenever the min. energy is reached or; shut off the weld before the expected (set) weld time if maximum energy value is reached
- **English (USCS)/Metric Units:** This feature allows the welder to be set up in the local units in use
- **Foreign Languages:** Software supports user selectable languages; English, French, German, Italian, Spanish, Traditional Chinese, Simplified Chinese, Japanese and Korean
- **Frequency Offset:** This process feature allows a user to set a frequency value, for certain specific applications, where the force imparted on the fixture or anvil causes a frequency shift in the Stack's operation. You should only use this feature when advised to do so by Branson

- **Graphs, Auto-Scaling:** When you request a graphical display in Time Mode, the power supply automatically scales the time axis of the graph to give you the most meaningful graph possible
- **Graphs of Power, Amplitude, Velocity, Collapse, Force, Frequency, and Horn Scan for the Power Supply:** The 2000Xc Series Actuator supports graphical display of these items. These graphs include markers to show critical points in the weld. Use these graphs to optimize your weld process or diagnose application problems
- **Graphs, User Selectable:** In any mode you can select the scale of the time axis on any graph so that you can zoom in on the start of the weld cycle
- **Horn Down:** Clamp On: When in the horn down mode, the start switches can be released after the part is contacted while the part remains clamped in place. Press Retract Horn button to release. Clamp Off: The horn will retract whenever the start switches are released in the horn down mode
- **Horn Down Display:** During Horn Down, the Absolute Distance, Force, Downspeed, and Pressure are displayed digitally so that you can determine correct values for process limits and cutoffs
- **Horn Down Mode:** A manual procedure used to verify system setup and alignment
- **Horn Scan:** A scan to enhance selection of operating frequency and control parameters
- **Limits, Control:** These are controls that are used in conjunction with the main weld mode. These user programmed limits provide for additional control of the weld process
- **Limits, Reject:** A class of user-definable process alarms that alert you if a part falls into a range that you classified as reject parts
- **Limits, Suspect:** A class of user-definable process alarms that alert you if a part falls into a range that you have determined should be inspected
- **Membrane Keyboard:** For high reliability and immunity from factory dust and oils
- **Parameter Entry through Keypad:** A keypad is provided for direct entry. Plus (+), and Minus (-) keys are provided for adjusting existing values
- **Parameter Range Checking:** If you enter an invalid parameter the power supply shows you the valid range
- **Password Protection:** This feature allows you to secure your setup from unauthorized changes. You can select your own password
- **Presets:** The Digital UPS is capable of storing presets of power supply operating parameters
- **Pressure Sensor:** Allows the power supply to read the system pressure
- **Pretrigger:** This feature allows you to set the system weld controls to turn the ultrasonics on before contact with the part to increase performance
- **Process Alarm Display Showing Actual and Set Values:** When an alarm condition has occurred, you can view the value for the last weld and the suspect and reject settings you programmed into the controls
- **Post Weld Seek:** This system feature provides a short burst of energy at the end of the weld Hold and Afterburst steps to automatically re-tune the power supply, if required
- **Ramp Time:** The starting of the 2000Xc Series Actuator and horn is done at the optimum rate to reduce electrical and mechanical stress on the system. This also helps make some tough-to-start applications possible
- **Rapid Traverse:** Allows a high horn travel speed for a portion of the stroke. Once the set distance is reached, travel speed is reduced to the downspeed setting
- **Safety Control System Monitoring:** The Safety Control System within the welder constantly monitors the system's safety related components for correct operation. When this system detects a fault condition, operation is interrupted and the system immediately goes to a safe state. A blinking of the power indicator light is used to signal a safety system alarm
- **S-Beam Load Cell/Dynamic Follow Through:** The load cell allows the ultrasonics to be triggered at a designated force input into the power supply
- **Seek:** Ensures operation at resonance; minimizes tuning errors; and operates the stack at low amplitude (approximately 5%), then provides a means of sensing and storing the resonant operating frequency value

- **Setup Checking:** If you create a setup with conflicts the power supply notifies you of the specific conflict
- **System Information Screen:** This is a screen that will give you information about your welding system (e.g., cylinder size, stroke length, number of cycles). Refer to this screen when contacting Branson for service and support
- **Test Diagnostics:** In Test mode you can view the ultrasonic system results using digital readouts and bar graphs
- **Timed Seek:** When turned ON, will do a Seek once every minute to update horn resonant frequency to memory. This is especially useful when the welding process affects the actual temperature of the horn, causing a resonant frequency shift
- **True Wattmeter:** The controls on the power supply include a true wattmeter for accurate measurement of power and energy
- **User-Nameable Presets:** You can refer to each preset by name or part number making identification of your presets simple
- **View Weld Results:** From the Run Screen you can view any of the information available from the last completed cycle
- **Weld Modes:** Time, Energy, Peak Power, Absolute, Collapse, and Ground Detect. The 2000Xc Series Actuator offers multiple weld modes so that you can choose the mode of control that best meets your specific application need
- **Weld Parameter Entry through Digital Keypad:** User Setup is direct and easy, by selecting the menu parameter by name and using the keypad to enter the precise value. The controls also support entry by incrementing existing values

2.4 Power Supply Front Panel Controls

Figure 2.3 2000Xc Power Supply Front Panel Display after Power-Up

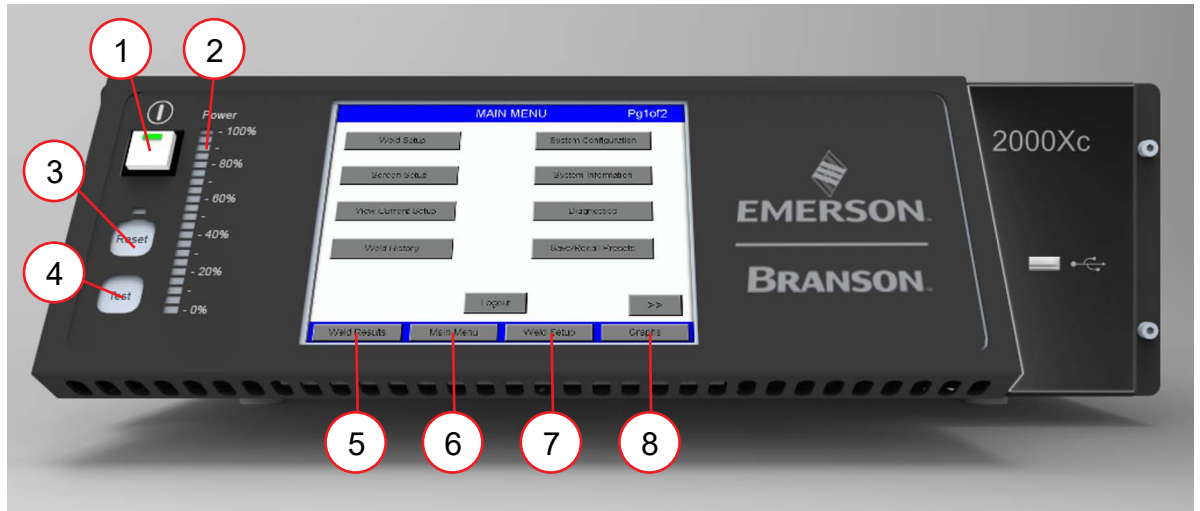



Table 2.2 2000Xc Power Supply Front Panel Display after Power-Up

Item	Name	Function
1	Power Button	Press to turn the system On and Off. When you depress the button, it lights to indicate power is On.
2	Power Bar Graph	Indicates the percentage of rated power delivered either during the last weld cycle or when Test is running. The indicator's scale can be increased for low-power settings.
3	Reset Button	Press to clear alarms. Reset only functions on the Run screen.
4	Test Button	Press to display a menu you can use to test the ultrasonic power supply, horn, booster, and converter.
5	Weld Results	Press to view 4 preselected parameters for the last 7 weld cycles.
6	Main Menu	Press to return to the Main Menu.
7	Weld Setup	Press to go to the Setup menu.
8	Graphs	Press to select to view graphs of Power, Amplitude, Velocity, Frequency, Distance, Auto Scale, or X Scale.

2.5 Actuator Controls and Indicators

The front panel controls on the 2000Xc Series Actuator are listed below.

- **Indicator Light:** Indicates that the actuator is connected to the power supply and that the power supply's main power is on. A blinking of the indicator light is used to signal a safety system alarm
- **Pressure Regulator:** Adjust the amount of air pressure applied to the cylinder; range of 10-100 psig (35-700 kPa)
- **Downspeed Control:** Downspeed is controlled through the power supply menu. Controls the rate of descent on the part to be welded
- **Carriage Door:** Provides access to the converter-booster-horn stack; secured by four captive hex screws. Use a M5 T-handle wrench to tighten the cap screws for the 2000Xc Series Actuator
- **Mechanical Stop:** Limits the stroke length to prevent the horn from contacting the fixture when no workpiece is in place; adjustment is approximately 0.04 in. (1 mm) per rotation; a locking ring keeps the setting from vibrating loose. Turning the knob clockwise increases the stroke length. There is an indicator on the side to provide a relative distance

NOTICE	
	The mechanical stop is not intended for welding by distance.

CAUTION	
	Turning the mechanical stop too far can cause it to come apart.

2.6 Glossary

The following terminology may be encountered when using or operating a 2000Xc Series ultrasonic welding system.

Table 2.3 Glossary

Name	Description
AB Amplitude	The amplitude at the horn face during the afterburst step.
AB Delay	Time delay between the end of the hold and the start of the afterburst.
AB Time	The duration of the afterburst.
Absolute Cutoff	Ends the ultrasonic portion of the cycle when the set absolute distance is reached.
Absolute Distance	The distance the horn has traveled from home (ULS deactivation).
Absolute Mode	A mode of operation in which the ultrasonic portion of the cycle is terminated when a user-specified distance from home has been reached.
Absolute Position	The position of the actuator after clearing the Upper Limit Switch.
Accept-as-is	A disposition permitted for a nonconforming item when it can be established that the item is satisfactory for its intended use without violating safety or functional requirements.
Act Clr Output	Actuator Clear output signal, sent upon the welder reaching a safe position of the actuator return stroke.
Actual	A reported value that occurred during the weld cycle. The converse is the set parameter that was requested during the setup.
Actuator	The unit that houses the converter, booster, and horn assembly in a rigid mounting allowing it to move up and down either mechanically or pneumatically to apply a predetermined pressure on the workpiece.
Afterburst	Ultrasonic energy applied after the hold step. Used to break away sticking parts from the tooling.
Alarm Beeper	An audible signal that sounds when a general alarm has occurred.
Alarm Log	A record of alarms that have occurred to the welder. Records time, date, alarm number, and cycle number.
Amp A	The amplitude applied to the part from the start of the weld to the step change.
Amp B	The amplitude applied to the part from the step change to the end of the weld.
Amp Control	The ability to set amplitude digitally or by an external control.
Amplitude	The peak-to-peak movement at the horn face. Always expressed as a percentage of the maximum.
Amplitude Graph	A graph of amplitude percentage plotted against time.

Table 2.3 Glossary

Name	Description
Amplitude Step	A change in amplitude during the ultrasonic portion of the cycle.
Authority Check	Enables Authority level functions and menus.
Auto Scale Graph	When turned on, the graph will be auto scaled, when off allows X Scale to set scale.
Automatic	A pretrigger condition indicating that pretrigger engages when the actuator leaves the upper limit switch.
Automation	Used in automation when an operator log in is not required. When in automation, weld setup and configuration menus are disabled.
Basic/Expert	Expert (default) allows access to all functions and menus of the welder. Basic limits the configuration and weld setup menus to a minimum number.
Batch Setup	Controls how many parts will be welded in a batch.
Beep	An audible signal produced by the Branson control board. Used to alert the operator to an unexpected condition or that trigger has been reached.
Booster	A one-half wavelength long resonant metal section mounted between the converter and horn, usually having a change in cross-sectional area between the input and output surfaces. Mechanically alters the amplitude of vibration at the driving surface of the converter.
Cal Actuator	Calibrate Actuator. Menus to guide the user through actuator calibration; distance can be verified.
Cal Sensor	The menu title for accessing the calibration and verification of pressure and force.
Clamping Force	The pressure exerted by the horn on the workpiece.
Cold Start	A condition that restores a setup to its default values. Note: Use Carefully.
Collapse Distance	The distance the horn has traveled from the trigger point of ultrasonics.
Collapse Mode	A mode in which the ultrasonics portion of the cycle is terminated when a user-specified distance from the trigger point has been reached.
Components Verify	Verification, before running a weld, that the system configuration's system components and the weld preset's system components match.
Control Limits	Additional parameters that determine the end of the ultrasonic portion of the cycle and the move to the hold state.
Converter	The device that converts electrical energy into mechanical vibrations at a high frequency (an ultrasonic rate). The converter is a central component of the welding system and is mounted in the actuator.

Table 2.3 Glossary

Name	Description
Counters	A record of the number of cycles run by category, for example, alarms, good parts, and so on.
Cycle Aborts	Settings that end the cycle immediately.
Digital Filter	A smoothing technique used to provide more meaningful data.
Digital Frequency	A specific starting frequency for a horn. Set to Default (recommended) for factory default starting frequency.
Downspeed	The user-definable speed of descent (percentage of maximum speed) during the down stroke of the actuator.
Downspeed Tuning	Run actuator test cycles for measuring speed and allowing fine adjustments to the speed setting.
Energy Braking	Allows the power supply time to reduce the amplitude before the sonics are shut off. Any overloads that occur will be ignored in this state. They will be handled in the hold state.
Energy Compensation	Extend the weld time up to 50% greater than the weld time setting or whenever the minimum energy is reached, or shut off the weld before the expected (set) weld time if the maximum energy value is reached.
Energy Mode	A mode of operation in which ultrasonics are terminated at a user-specified energy value.
Event History	A record of changes made to the welder configuration and weld setup. Records time, date, user ID and comments made for changes. Used for audit purposes.
Executive	Highest authority level allowed to the power supply. The Executive has access to all configuration and weld setup features. Only the Executive can create or modify the User ID Setup. Multiple Executive level users can be created in the User ID table. The User ID table must contain at least one Executive user.
External Amplitude Control	Enables you to access real-time amplitude control directly.
External Frequency Control	Enables you to access real-time frequency control directly.
External U/S Delay	If External Trigger Delay is enabled, weld state machine shall wait for external trigger delay input to become active in less than 30 seconds. When the time expires and input is still inactive, alarm will be recorded and cycle aborted.
Extra Cooling	When On, allows cooling air to start when upper limit switch is triggered and remains on throughout the cycle. When Off, air is applied at ultrasonics application.
F Actual	Actual Frequency. The operating frequency of the ultrasonic stack, as measured during a cycle.

Table 2.3 Glossary

Name	Description
F Memory	Frequency as stored in the power supply memory. The intended operating frequency value for an ultrasonic stack, stored in the memory of the power supply.
Force	Weld Force. The mechanical force applied to the part during the cycle.
Force Act	Actual Force. The measured mechanical force determined from the results of a weld cycle.
Force Graph	Displays force in pounds as a function of weld time.
Force/Col Graph	Dual display of collapse distance in inches and force in pounds as a function of time.
Freq Chg	Frequency Change. (Frequency at Start versus Frequency at End).
Freq End	The frequency at the end of the ultrasonic portion of the welding cycle (when ultrasonics are terminated).
Freq Max	Maximum Frequency. Highest frequency reached during weld cycle.
Freq Min	Minimum Frequency. Lowest frequency reached during weld cycle.
Freq Start	Frequency at Start. Frequency at the time ultrasonics was turned on.
Frequency	The operating frequency of the ultrasonic stack. The frequency stored is measured at the end of the ultrasonic portion of the cycle (when ultrasonics are terminated).
Frequency Graph	Displays operating frequency as a function of time.
Frequency Offset	An offset factor applied to the ultrasonic frequency stored in the power supply.
General Alarm	An alarm that occurs due to system fault and/or tripping a limit.
Gnd Det. Mode	Ground Detect Mode, available in all models of 2000Xc Power Supply. In this mode of operation, ultrasonics are terminated after detection of a ground condition between the horn and fixture or anvil.
Ground Det. Cutoff	Ground Detect Cutoff. Immediately terminates the weld process, including the hold step, when a ground detect has occurred.
Hold Force	The force on the part during the hold portion of the cycle.
Hold Pressure	The pressure applied during the hold portion of the cycle. If set to Default, hold pressure equals weld pressure.
Hold Time	The duration of the hold step.
Horn Clamp	If set to ON, the horn will stay down and hold the part in place in the event of an alarm. A Supervisor can reset it and remove the part.

Table 2.3 Glossary

Name	Description
Horn Down	A mode in which ultrasonics are locked out and the user can advance the actuator for setup and alignment.
I/O Connector	Presets 1 through 32 are available.
Key	Reserved for special product configuration codes.
Linear Encoder	Provides carriage (horn) distance measurement during the actuator cycle.
Main Menu	The list of categories of features available in the software, as displayed on the front panel of the power supply.
Max Energy	Maximum Energy. The maximum user-specified energy that produces a part without an alarm. Used with energy compensation to turn off the weld in Time mode.
Memory Full	Does not allow any welding until memory is cleared. Memory can be cleared by using Copy Now and deleting memory. If set to Continue, the system will write over older memory.
Min Energy	Minimum Energy. The minimum user-specified energy that produces a part without an alarm. Used with energy compensation to extend the weld to up to 50% of the weld time in Time mode.
Minus Limit	The user-defined lower limit, or lower extreme of an acceptable range for a given parameter. Used with suspect and reject limits.
Missing Part	A min/max distance where trigger is expected. Returns the actuator to the home position and displays an alarm indicating that the cycle was aborted because no part was present.
Operator	Authority level below Technician. The Operator can run a weld and view system information, weld history, and current setup. The Operator cannot access the weld setup or configuration menu.
Operator Authority	Special authority rights granted to operators beyond the basic level of welder operation. The setting for this is global and applies to all operator level users. Multiple Operator level users can be created in the User ID table.
P/Col Graph	Dual Display of % power and collapse distance as a function of time.
P/Force Graph	Dual display of % power and force as a function of time.
Parameter Range	Valid range of parameters accepted for a particular setup.
Part-ID Scan	A USB barcode reader or similar device must read and record the part ID before allowing the weld to occur. When set to ON and after a weld cycle, the welder will stay out of ready mode until another part ID is read. If set to OFF, no part ID reading is required before a weld.
Password Recovery Kit	PRK. A dongle that plugs into the back of the power supply to disable authority check.

Table 2.3 Glossary

Name	Description
Peak Power	A weld mode in which obtaining a power value (percentage of full power) will cause the ultrasonic energy to terminate.
Peak Power Cutoff	A power value that terminates the ultrasonics when peak power is not the primary control mode.
Plus Limit	The user-defined upper limit. See Control Limits, Suspect, Reject and Missing Part Limits.
Pneumatic Air Prep	This is a panel that mounts the cutoff valve, filter, and slow start valve that are normally located in the actuator. This panel is required for installations where the actuator is not positioned in a vertical plane, or is used without a Branson actuator support.
Post Weld Seek	Used to determine the operating frequency of the Stack, after the Hold and/or Afterburst portion of the weld cycle. Ultrasonics are run at a low level (5%) amplitude during this step, and the frequency is stored to memory.
Power Graph	A graph of power in percentage of maximum plotted against time.
Preset	User-stored parameters constituting a weld setup. Saved in non-volatile memory in the power supply, can be recalled for quick Setup of the system.
Preset Barcode Start	The character set for the Preset Barcode Start will indicate a preset is to be recalled. The number following the character indicates which preset number. Example; Preset Barcode Start = P indicates if a barcode reader sees the letter P as the first character of a barcode, it will recall a preset based on the number after P on the barcode.
Preset Name	The ability to name a preset in customer-defined terms.
Presets, External Selection	Presets can be changed externally using 5 user inputs on the user.
Pressure Limits	Minimum and Maximum weld pressure limits.
Pressure Step	A change in weld pressure during the ultrasonic portion of the cycle. Pressure A must be less or equal to Pressure B.
Pretrig @ D	The distance at which pretrigger is turned on.
Pretrig Amp	Pretrigger Amplitude. The amplitude at the horn face during pretrigger.
Pretrigger	The setting that causes ultrasonics to start before contact with the part (or, before the set Trigger Force has been met).
Rapid Traverse/ RAPID TRAV	Allows fast actuator descent to a user-defined point, before the Downspeed value is applied for control during the stroke.
Ready Position	State in which the welder is retracted to the home position and ready to receive the start signal, ready to operate.
Recall Preset	Allows a user to activate a preset from memory for purposes of operation or modification.

Table 2.3 Glossary

Name	Description
Reject Limits	User-definable limits at which the violating cycle is identified as having produced a bad part.
Reset Required	State used with limits indicating that a reset will be required when the limit is exceeded. The reset is accomplished by using the reset key on the front of the power supply, or by external reset at the User I/O.
Run Screen	The screen showing weld status, alarms, weld count, and process information. Available using a front-panel button on the power supply.
S-Beam Load Cell	Provides force measurement for accurate ultrasonic triggering and graphing of force.
Scrub Time	In Ground Detect mode, the amount of time after detection of a ground condition before the termination of ultrasonics, and end of the cycle.
Seek	The activation of ultrasonics at a low-level (5%) amplitude, for the purpose of finding the resonant frequency of the Stack.
Setup Limits	Minimum and maximum parameter changes allowed for a weld preset.
Stack	Converter, Booster, and Horn.
Start Frequency	The frequency stored in memory and the starting frequency of the horn.
Step @ Col (in)	User-definable collapse distance at which AmpA is changed to AmpB.
Step @ E (J)	User-definable energy at which AmpA is changed to AmpB.
Step @ Ext Sig	Allows you to step Amplitude based upon an external signal.
Step @ Pwr (%)	User-definable power at which AmpA is changed to AmpB.
Step @ T (S)	User-definable time at which AmpA is changed to AmpB.
Supervisor	Authority level below Executive. The Supervisor has access to all configuration and weld setup features. Multiple Supervisor level users can be created in the User ID table.
Suspect Limits	User-definable limits at which the resultant weld in a welding cycle is identified as potentially bad (suspect).
SV Interlock	SV Interlock input allows power supply to close an auxiliary door.
Sys Components	System Components. Assign names to the power supply, actuator, and stack. Assigned names will become part of the system configuration and weld preset.
Technician	Authority level below Supervisor. The supervisor can create and save a weld setup, perform a horn down test, and run diagnostics. The technician cannot validate, lock, or unlock a validated preset. The technician cannot access the configuration menu. Multiple Technician level users can be created in the User ID table.

Table 2.3 Glossary

Name	Description
Test Scale	The magnification of the power bar on the front panel of the power supply, useful for lower-power applications that want a more accurate (but smaller) scale.
Time Mode	Terminates the ultrasonics at a user-specified time.
Timeout	A time at which the ultrasonic energy terminates if the main control parameter has not been reached.
Trig Delay	Trigger Delay. A user-programmable time delay between engagement of the trigger switch and start of ultrasonics and ramping of force to the weld force.
Trigger	Trigger force triggers the start of ultrasonics based on a set force level. Trigger distance triggers the start of ultrasonics based on a set travel distance. Trigger distance doesn't consider force when used.
Trigger Beeper	An audible signal sounded when the trigger is made.
Upper Limit Switch (ULS)	A switch when activated indicates the actuator is in the home position.
UPS	Power supply module.
USB Copy Now	Allows a PDF copy of weld history, event history, weld setup, and User ID table to be copied to a USB flash drive. The flash drive must be installed for this function to appear.
USB Streaming Data Setup	Allows real time recording of weld data and graphs to a USB flash drive. The weld data and graphs can be viewed on a PC using the Branson Weld History Utility Program.
User I/O	The User I/O is used to configure actuator inputs and outputs. This menu can only be entered when the welder is not in a weld cycle.
User ID Setup	Add and modify users allowed access to the power supply.
User-defined Limits	<p>For process resultants, where - is the user-defined lower limit, and + is the user defined upper limit:</p> <ul style="list-style-type: none"> • -/+ S/R Energy: The energy reached during the weld • -/+ Force: The force at the end of the weld • -/+ S/R Freq: The peak frequency reached during a weld • -/+ S/R Power: The peak power as a percentage of the maximum reached during the weld • -/+ S/R Abs D: The absolute distance reached during the weld from the Upper Limit Switch • -/+ S/R Col D: The collapse distance reached from trigger to end of weld • -/+ S/R Trg D: The distance at which the trigger occurred • -/+ S/R Time: The weld time reached during the weld
Velocity Graph	A graph of the velocity of the actuator during weld.

Table 2.3 Glossary

Name	Description
View Setup	Available in Main Menu as a read only menu identical to the Weld Setup menu. It is not password protected even if the Weld Setup menu is protected.
Weld Count	Count of acceptable weld cycles.
Weld Energy	The energy specified to be applied to the part during the weld cycle.
Weld Force	The force at the end of the weld cycle.
Weld History	The last 100,000 weld summary data lines are saved.
Weld History Setup	Selects which characteristics will appear in the power supply Weld History screen.
Weld Results	A summary of information concerning the last weld cycle.
Weld Scale	The power bar LED scale during weld.
Weld Time	The time for which ultrasonics are on.
Windows Setup	Allows access to the Microsoft Windows screen.
Write In Fields	Assign a unique alphanumeric to a specific weld setup and cycle.
X Scale Graph	Allows a scaling factor to be applied when auto scale is turned off.

2.7 21 CFR Part 11 Capability

The Branson 2000Xc welding system is capable of helping the user meet FDA's 21 CFR Part 11 regulations. The 2000Xc system should be set to Authentication mode to when complying to 21 CFR Part 11 requirements. The intended use is for Subpart B-Closed Systems- Section 10, since the 2000Xc produces and stores data.

The data generated from the 2000Xc are in readable format and can be copied in a PDF format to a USB flash drive or downloaded from the Ethernet port using webservices. The data in the 2000Xc is buffered and saved in the system but is limited in storage capacity. To open up storage capacity for new data, the current data can be copied to a USB flash drive or downloaded with webservices. After copying or downloading the data can be deleted.

User authorized access and authority check security is set in the 2000Xc configuration. Controls can be setup to govern frequency of password change, idle log out time, and ability to disable accounts. User IDs must be unique and industry standards for password complexity are used.

Audit trails are accessible from the event history screen. Changes made to validated weld presets, system configuration, and user ID authority table are recorded in the event history along with the logged in user, time, date, and comments for the changes made.

Chapter 3: Delivery and Handling

3.1 Shipping and Handling36
3.2 Receiving37
3.3 Unpacking38
3.4 Returning Equipment39

3.1 Shipping and Handling

CAUTION	
	<p>The Power Supply internal components are sensitive to static discharge. Many components can be harmed if the unit is dropped, shipped under improper conditions or otherwise mishandled.</p>

3.1.1 Environmental Specifications

The internal components of both the Power Supply and Actuator are sensitive to electrostatic discharge, and many of their components can be harmed if the unit is dropped, shipped under improper conditions, or otherwise mishandled.

The following environmental guidelines should be respected in the shipping of the Actuator and Power Supply.

Table 3.1 Environmental Specifications

Environmental Condition	Acceptable Range
Humidity	Maximum 85%, non-condensing
Storage / Shipping Temperature	-25° C/-13° F to +50° C/+122° F (+70° C/+158° F for 24 hours)
Shock / Vibration (transit)	60 g shock / 0.5 g and (3-100 Hz) vibration per ASTM 3332-88 and 3580-90

3.2 Receiving

Branson Actuator and Power Supply units are carefully checked and packed before dispatch. It is recommended, however, that you follow the procedure below upon receiving your Welding System.

Inspect the equipment when it is delivered:

Table 3.2 Receiving

Step	Action
1	Check the equipment immediately after delivery to ensure that they have not been damaged during transport.
2	Verify that all parts are complete according to the delivery note.
3	Determine if any component has become loose during shipping and, if necessary, tighten screws.

NOTICE	
	If the goods delivered have been damaged during shipping, please contact the forwarding agent immediately. Retain packing material (for possible inspection or for sending back the unit).

CAUTION	
	The Actuator and the Power Supply are heavy. Handling, unpacking, and installation may require the assistance of a colleague or the use of lifting platforms or hoists.

3.3 Unpacking

3.3.1 Actuator Assemblies

Actuator assemblies are heavy and packed in a protective shipping container. The Booster, Converter, and Actuator Toolkit are often packed inside the shipping container.

Each Actuator is shipped as one of the two assemblies described below, with its own corresponding unpacking procedure. These assemblies vary in both the materials used for shipping and the actual components that you will receive when the Actuator is shipped. For complete Actuator unpacking and installation procedures, refer to [Chapter 5: Installation and Setup](#)

- **Stand (Actuator on Base):** A stand consisting of an Actuator on a Base is shipped on a wooden pallet with a cardboard box cover. (The packaging for this assembly is similar to that of an Actuator on Hub-Mounted Column)
- **Actuator (Alone):** An Actuator that does not use either type of stand is shipped in a rigid cardboard box using protective foam shells for support

3.3.2 Power Supply

The Power Supply is fully assembled. It is shipped in a sturdy cardboard box. Some additional items are shipped in the box with the Power Supply.

When unpacking the Power Supply, take the following steps:

Table 3.3 Unpacking Procedure

Step	Action
1	Unpack the Power Supply as soon as it arrives. Save the packing material.
2	Inspect the controls, indicators, and surface for signs of damage.
3	Remove the cover of the Power Supply to check if any components became loose during shipping.

NOTICE	
	<p>If damage has occurred, notify the shipping company immediately. Retain packing materials for inspection.</p>

3.4 Returning Equipment

If you are returning equipment to Branson Ultrasonics Corporation, please call your Customer Service Representative to receive approval to return goods to Branson.

If you are returning equipment for repair refer to [1.5 Returning Equipment for Repair](#) of this manual, for appropriate procedure.

Chapter 4: Technical Specifications

4.1 Technical Specifications.42
4.2 Physical Description.45

4.1 Technical Specifications

4.1.1 Requirement Specifications

The 2000Xc Series Actuator requires compressed air. The factory air source must be “clean (5 micron) and dry”, that is, does not include moisture or lubricants. The Actuator requires 70 psi minimum pressure for operation and cooling, and can require up to 100 psig maximum, depending on the application. The following table lists environmental specifications for the ultrasonic welder.

Table 4.1 Environmental Specifications

Environmental Concern	Acceptable Range
Humidity	Maximum 85%, non-condensing
Ambient Temperature	+5° C to +40° C (+41° F to +104° F)
Storage/Shipping Temperature	-25° C/-13° F to +50° C/+122° F (+70° C/+158° F for 24 hours)

All electrical input power connections are to the Power Supply.

4.1.2 Performance Specifications

The following tables detail some of the performance specifications associated with the 2000Xc Series Actuator.

Table 4.2 Maximum Welding Force (at 100 psig and 4.0" stroke)
For 2000Xc AEC Actuator

1.5" cylinder	135 lb. / 61.4 k.
2.0" cylinder	269 lb. / 122.3 k.
2.5" cylinder	441 lb / 200.5 k.
3.0" cylinder	651 lb. / 295.9 k.
3.25" cylinder	772 lb. / 350.9 k.

For 2000Xc Micro Actuator

Φ32mm cylinder	112 lb. / 51.0 k.
Φ40mm cylinder	180 lb. / 81.6 k.

Table 4.3 Dynamic Trigger Force
For 2000Xc AEC Actuator

1.5" and 2.0" cylinder	5 lb. / 2.25 k. to max force
2.5", 3.0", and 3.25" cylinder	10 lb./ 4.5 k. to max force

For 2000Xc Micro Actuator

Φ32mm cylinder	5 lb. / 2.25 k. to max force
Φ40mm cylinder	5 lb. / 2.25 k. to max force

Table 4.4 Dynamic Follow-Through
For 2000Xc AEC Actuator

1.5", 2.0"	15 lb. / 6.8 k. to max force
2.5", 3.0", 3.25"	15 - 400 lb. / 6.8 - 181.8 k.

For 2000Xc Micro Actuator

Φ32mm cylinder	10 lb. / 4.5 k. to max force
Φ40mm cylinder	10 lb. / 4.5 k. to max force

Table 4.5 Maximum Traverse Speed (application dependant) For 2000Xc AEC Actuator

Down and Return Speed	Up to 7 inch/ 177.8 mm per sec. max at 3.5-inch / 88.9 mm stroke, 90 psi (all cylinder sizes)
-----------------------	---

For 2000Xc Micro Actuator

Down and Return Speed	Up to 7 inch/ 177.8 mm per sec. max at 2.5-inch / 63.5 mm stroke, 80 psi (all cylinder sizes)
-----------------------	---

For 2000Xc AEC Actuator

Minimum Stroke: 1/8" / 3.2 mm

Maximum Stroke: 3-3/4" / 95.2 mm (for a 4" cylinder)

For 2000Xc Micro Actuator

Minimum Stroke: 6.5mm

Maximum Stroke: 70mm

4.2 Physical Description

Refer to [Chapter 5: Installation and Setup](#) for dimensional information.

4.2.1 Standard Items

Actuator Support

The actuator support is firmly clamped to the column. With the actuator support, you can adjust the height of actuator housing above the fixture position. You can set the height as needed for your application, or to facilitate servicing.

Actuator Base

Table 4.6 Description of Controls on Base

Name	Description
Start Switches	Activate the operating cycle through the actuator to the power supply when pressed simultaneously.
Emergency Stop Button	Interrupts the operating cycle (through the power supply) and causes the carriage to retract. Twist to reset.
Start Cable	Connects base to START connector on Actuator.

CAUTION	
	This equipment is designed to be operated by one (1) person only.

Slide Mechanism

The slide mechanism is based on eight sets of preloaded, permanently lubricated bearings, providing consistent, precise alignment of the horn, smooth linear motion, and long-term reliability.

Limit Switch

The optical Upper Limit Switch (ULS) signals the control circuits in the power supply that the carriage has returned to the top of its stroke (home) and is ready to start another operating cycle.

The power supply uses the signals from the actuator to perform various control functions, as in the following examples:

- **Indexing Control:** In automated systems, the Linear Encoder generates an Actuator Clear signal at a preset distance along the travel of the horn. This signal can be used to trigger a safety interlock switch, controlling movement of the material handling equipment (indexing) before the horn is fully retracted
- **Automatic Pretriggering:** A 2000Xc Series Power Supply can use the ULS signal, or encoder distance, to activate ultrasonics before the horn contacts the workpiece. Pretriggering is used with large or difficult-to-start horns and in specialized applications

Mechanical Stop

The mechanical stop limits the downward travel of the horn. To prevent equipment damage, adjust the stop so that the horn will not contact the fixture when no workpiece is in place. For 2000Xc AEC actuator, there is an indicator on the right side showing the position of the stop block. For 2000Xc Micro actuator, the indicator is not available, only adjust the position of stop by rotating the limited screw and using the nut to lock it. It is not intended for use in welding by distance.

CAUTION	
	For 2000Xc AEC actuator, do not loosen the top hex-headed nut. Damage to the mechanical stop can result.

NOTICE	
	Turning clockwise will increase the stroke length; turning counter-clockwise will shorten the stroke length. Adjustment is approximately 0.04-inch (1 mm) per rotation.

Pneumatic System

The pneumatic system is contained within the actuator and the remote pneumatics box. The system consists of:

- Primary solenoid valve
- Rapid traverse valve
- Cooling solenoid valve
- Air cylinder
- Pressure regulator
- Air-pressure indicator
- Down speed flow control valve and check

Figure 4.1 2000Xc Series Actuator Pneumatic System
2000Xc AEC Actuator Pneumatic System

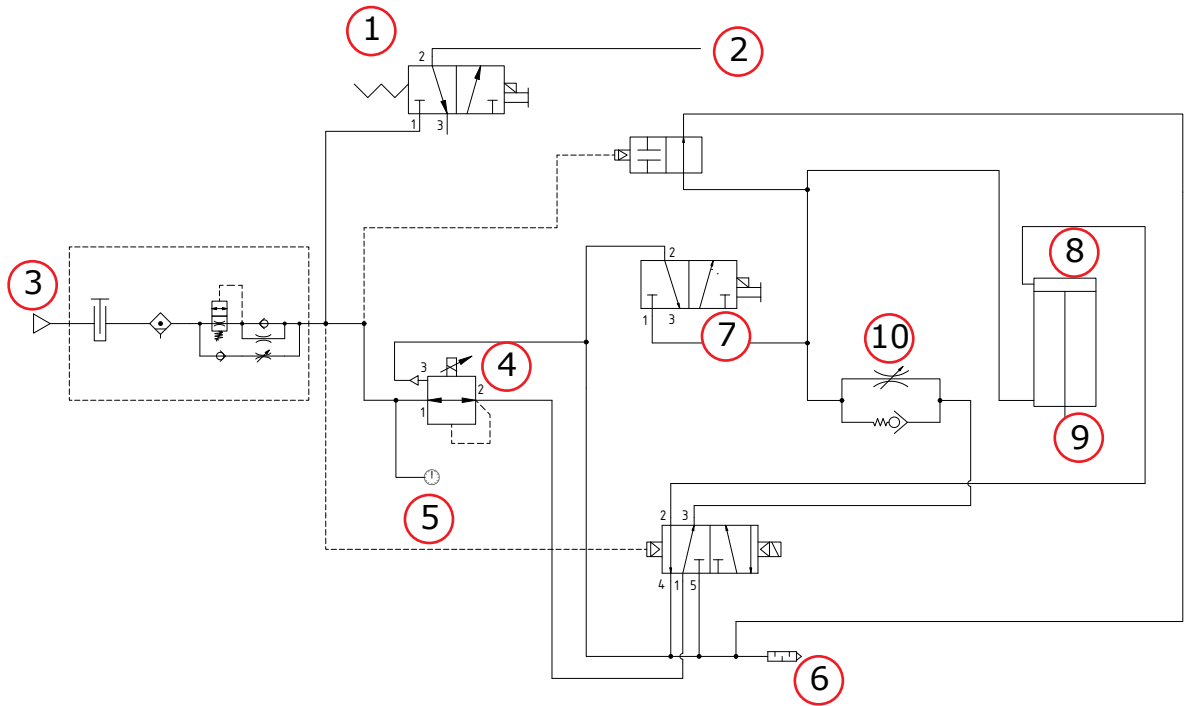

2000Xc Micro Actuator Pneumatic System

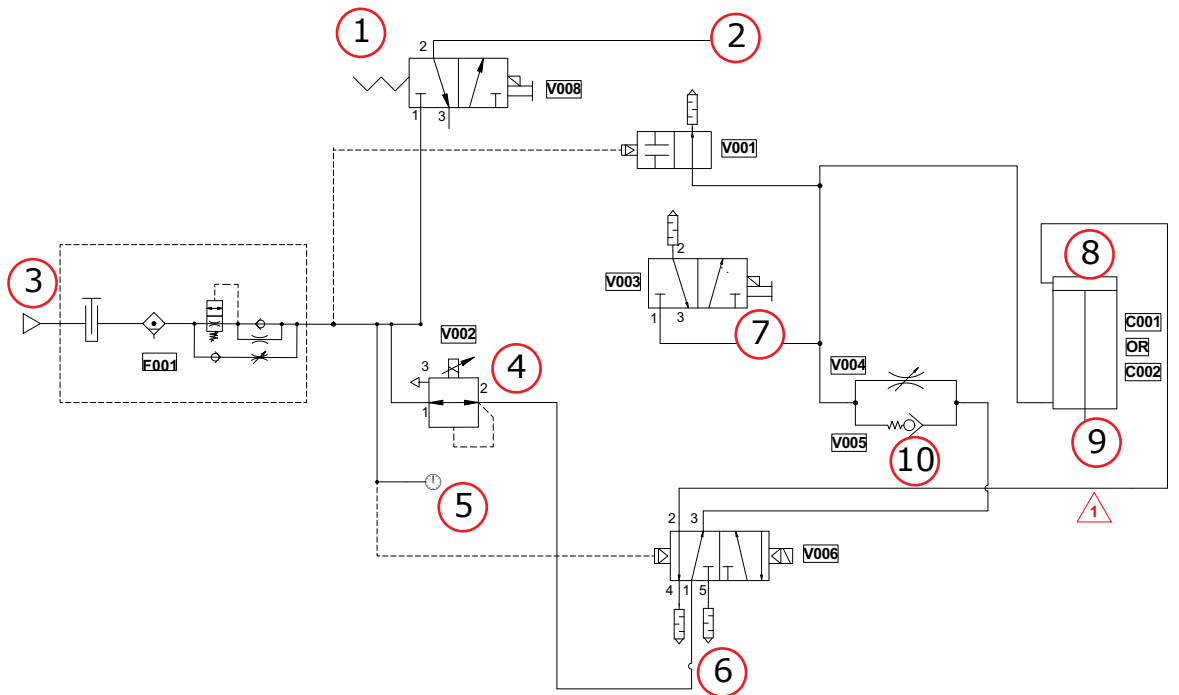

Table 4.7 2000Xc Series Actuator Pneumatic System

Item	Description
1	Cooling Valve
2	Cooling Conn. Reducer to RF Harness
3	Supply Pressure
4	Electronic Regulator
5	Pressure Indicator
6	Muffler
7	Rapid Traverse Valve
8	Cylinder Top
9	Cylinder Bottom
10	Electronic Flow Control

S-Beam Load Cell and Dynamic Follow Through

The S-Beam Load Cell measures the force being applied to the part to trigger ultrasonics and record the welding parameters. The ensures that pressure is applied to the part prior to the application of ultrasonic energy.

To maintain horn-to-part contact and force as the joint collapses, provide dynamic follow-through. As the plastic melts, the ensure smooth transmission of ultrasonic energy into the part.

Linear Encoder

The encoder measures the distance the horn has traveled. Depending on the power supply settings, it can:

- Allow for distance welding
- Detect improper setup controls
- Monitor the quality of the weld
- Decrease cycle time by generating signal to initiate indexing of material handling equipment before horn is fully retracted

Chapter 5: Installation and Setup

5.1	About Installation	50
5.2	Handling and Unpacking	51
5.3	Take Inventory of Small Parts	54
5.4	Installation Requirements	56
5.5	Installation Steps	66
5.6	Guards and Safety Equipment	80
5.7	Rack Mount Installation	81
5.8	Assemble the Acoustic Stack	83
5.9	Mounting the Fixture on the Base Hardware and mounting holes	91
5.10	Testing the Installation	93
5.11	Still Need Help?	94

5.1 About Installation

This chapter is intended to help the installer with the basic installation and setup of your new 2000Xc Series welding system.

CAUTION	
	The actuator and related components are heavy. Handling, unpacking, and installation can require help or the use of lifting platforms or hoists.

International safety labels are found on the power supply and actuator. Those that are of importance during installation of the system are identified in the figures in this and other chapters of this manual.

5.2 Handling and Unpacking

If there are any visible signs of damage to the shipping containers or the product, or you later discover hidden damage, notify your carrier immediately. Save the packing material.

1. Unpack the 2000Xc Series components as soon as they arrive. Refer to the following procedures.
2. Verify you have all of the equipment ordered. Some components are packed inside other boxes.
3. Inspect the controls, indicators, and surfaces for signs of damage.
4. Save all packing material, including the pallets and wood spacer blocks. Evaluation systems will be returned using this packing material.

5.2.1 Unpack the Power Supply

Power supplies are shipped in a cardboard carton. It weighs approximately 40 lbs.

1. Open the box, remove the two foam top packing halves and lift the power supply out.
2. Remove the toolkit(s) and other components shipped with the power supply. These items may be shipped in small, separate boxes, or underneath the power supply in the box.
3. Save the packing material; evaluation systems will be returned using this packing material.

5.2.2 Unpack the Stand or Actuator

The stand (or actuator) is heavy and packed in a protective shipping container. The actuator toolkit is packed with the actuator. A booster, converter and other components may be packed inside the shipping container (depending on the equipment ordered).

- Stands are shipped on a wooden pallet with a cardboard box cover
- Actuators (alone) are shipped in a rigid cardboard box using protective foam shells for support

Figure 5.1 Linear Encoder

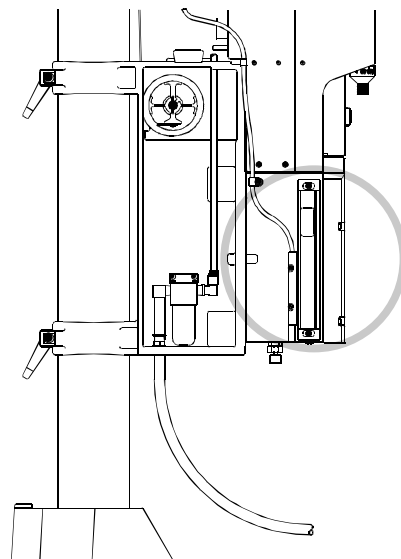

2000Xc AEC Actuator

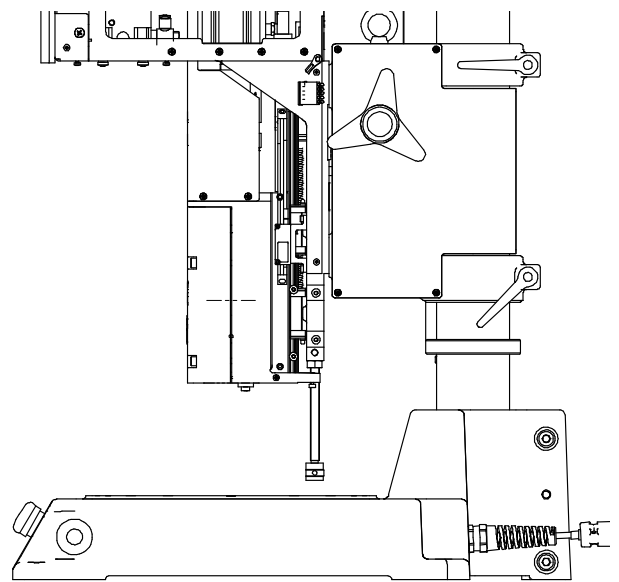

2000Xc Micro Actuator

CAUTION	
	<p>The linear encoder (on the left side for 2000Xc AEC and inside of the actuator for 2000Xc Micro) is very sensitive. Do not use the linear encoder assembly as a hand-hold, allow no impact on it, and do not place any weight on it.</p>

Depending on which one of the following options applies to you, unpack the Branson actuator assembly:

5.2.3 Stand (actuator on a base)

Heed the "This End Up" arrows and the "Open Top First" instructions. The packaging is designed to be removed from the assemblies from an upright orientation only.

Figure 5.2 Unpacking the Stand (Actuator on a Base)

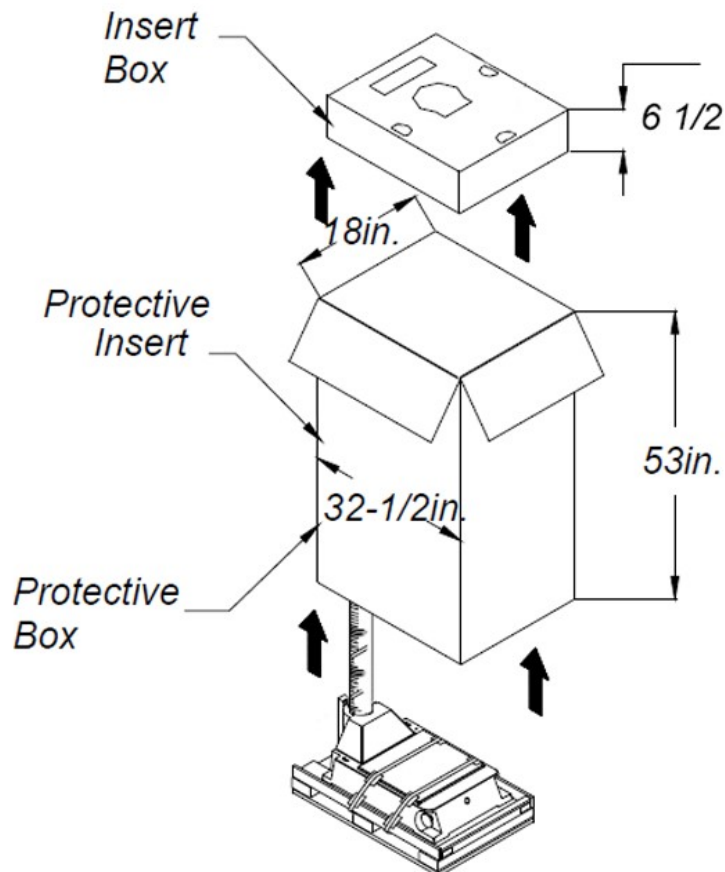

- Move the shipping container close to the intended installation location, leave it on the floor
- Open the top of the box. Remove the insert from the top of the protective box.
- Remove the staples at the bottom of the protective box. Lift the protective box off the pallet

- Remove the protective insert around the actuator

CAUTION	
	<p>The column and column support are under spring tension from the counterbalance spring. Do NOT attempt to disassemble the column from the stand, but always keep the column support clamped together. When making height adjustments, carefully and slowly release the clamps to control the motion, and hold the stand to prevent sudden movements or injury.</p>

- Cut the two packing straps around the base and pallet. Pry off the two wooden shipping blocks (to the rear of the base) which prevent the base from sliding on the pallet
- The stand can now be moved into its desired location by sliding it off the pallet. Stands have a lifting hook for the use of overhead hoists to lift the assembly in place
- Remove the block of wood between the base and the column support by carefully loosening the two column clamps (allowing the actuator to rise slightly, but not allow sudden movements) and then cutting the shipping tape on the block of wood. **RETIGHTEN THE COLUMN CLAMPS**
- Unpack the toolkit, insert box, and other parts (converter, booster, etc.) that may have shipped with the stand. Save the packing material
- Go to [5.3 Take Inventory of Small Parts](#). See [Table 5.1](#).

5.2.4 Actuator (Alone)

The actuator, if shipped alone, is assembled and ready to install.

- Move the shipping container close to the intended installation location, leave it on the floor
- Open the top of the cardboard box, remove the insert from the top of the box and set it aside
- The toolkit, mounting bolts, and converter and/or booster are shipped with the actuator but in separate shipping box(es). Unpack the converter, booster, toolkit and bolts from their packages
- Save the packing material

NOTICE	
	<p>The packaging may also include the converter and/or booster, if ordered.</p>

Figure 5.3 Ultrasonic Converter (J-Type for Stand-Alone Use) and Booster



5.3 Take Inventory of Small Parts

Table 5.1 Small Parts included (=x) with Power Supply and/or Actuator Assemblies

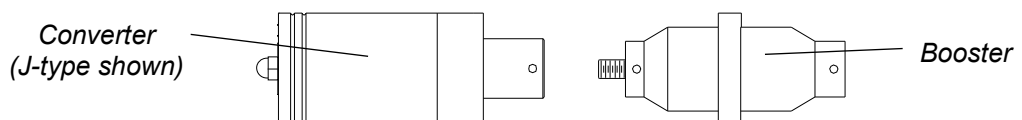
Part or Kit	2000Xc Series Actuator			Actuator	
	20 kHz	30 kHz	40 kHz	Stand (Base)	(Alone)
T-Handle Wrench				x	x
Mylar Washer Kit	x	x			
Silicone Grease			x		
Actuator Mtg. Bolts					x
20 kHz Spanners (2)	x				
30 kHz Spanners (2)		x			
40 kHz Spanners (2)			x		
40 kHz Sleeve (2000Xc Micro actuator is not required)				Ordered part	Ordered part
40 kHz Sleeve Spanner				Ships w/ sleeve	Ships w/ sleeve
Fixture Bolts and Washer				x	
M8 Allen Wrench				x	

5.3.1 Cables

Two cables connect the power supply and actuator: the actuator interface cable, and the RF cable. For other interfacing requirements, you may also need a user I/O cable. Check your invoice for cable types and cable lengths.

Table 5.2 List of Cables

Part Number	Description
101-241-203	Actuator Interface, 8' (J925S)
101-241-204	Actuator Interface, 15' (J925S)
101-241-205	Actuator Interface, 25' (J925S)
101-241-207	User I/O, 8' (J957S)
101-241-208	User I/O, 15' (J957S)
101-241-209	User I/O, 25' (J957S)
101-240-176	RF, CE - 8' (J931CS)
101-240-177	RF, CE - 15' (J931CS)
101-240-178	RF, CE - 25' (J931CS) Note: Not for 30 kHz or 40 kHz systems
101-240-179	RF, CE - 8' (J934C)
159-240-188	RF, 15` RT ANGLE
159-240-182	RF, CE - 20' (J934C)
100-246-630	Ground Detect Cable (only for 2000Xc AEC actuator)
560-257-358	Ground Detect Cable (only for 2000Xc Micro actuator)

5.4 Installation Requirements

This section covers the location options, dimensions of the major assemblies, environmental requirements, electrical requirements and factory air requirements, to help you plan and execute your installation successfully.

5.4.1 Location

The actuator or stand may be installed in a variety of positions. The stand (on a base) is often manually operated, using its base-mounted start switches, and so is installed at a safe and comfortable workbench height (approximately 30-36 inches) with the operator sitting or standing in front of the system. Actuators alone can be mounted in any orientation. Contact Branson if mounting upside down.

The stand may tip over if moved around the axis of its column, if not properly secured. The work surface on which a stand is installed must be sturdy enough to support it, and secure enough to not tip over when the stand is adjusted during installation or setup.

The 2000Xc Series Actuator must not be positioned so that is difficult to plug in or unplug the main power plug.

The power supply may be located up to 50 feet away for 20 kHz (20' for 30 kHz, and 15' for 40 kHz models) from the actuator. The power supply must be accessible for user parameter changes and settings, and must be placed in a horizontal orientation. The power supply should be positioned so it does not draw in dust, dirt or material via its rear fans. Refer to the illustrations on the pages that follow for a dimensional drawing of each component. All dimensions are approximate and may vary between models:

[Figure 5.4.](#)

[Figure 5.5.](#)

Figure 5.4 Power Supply Dimensional Drawing

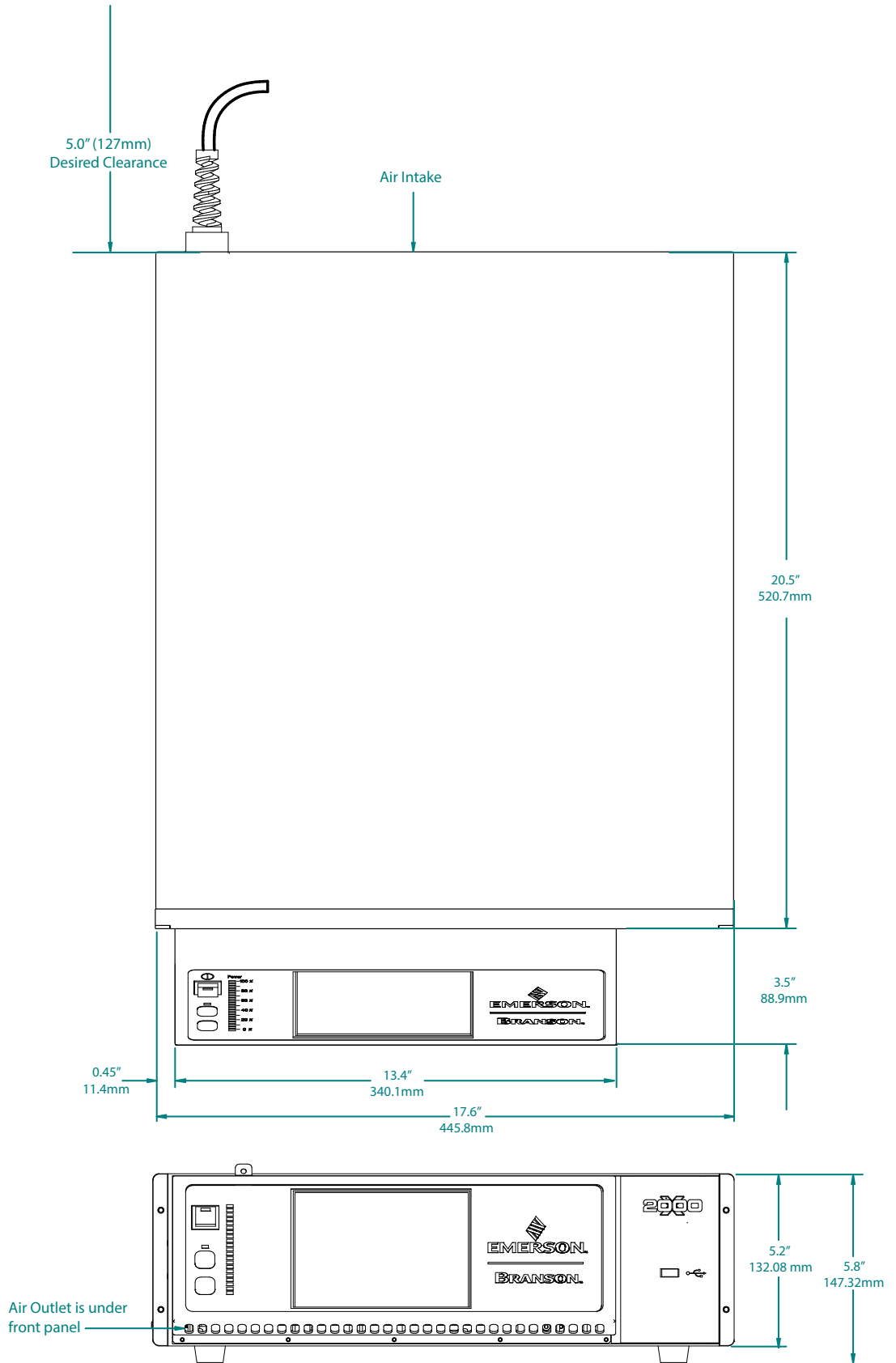
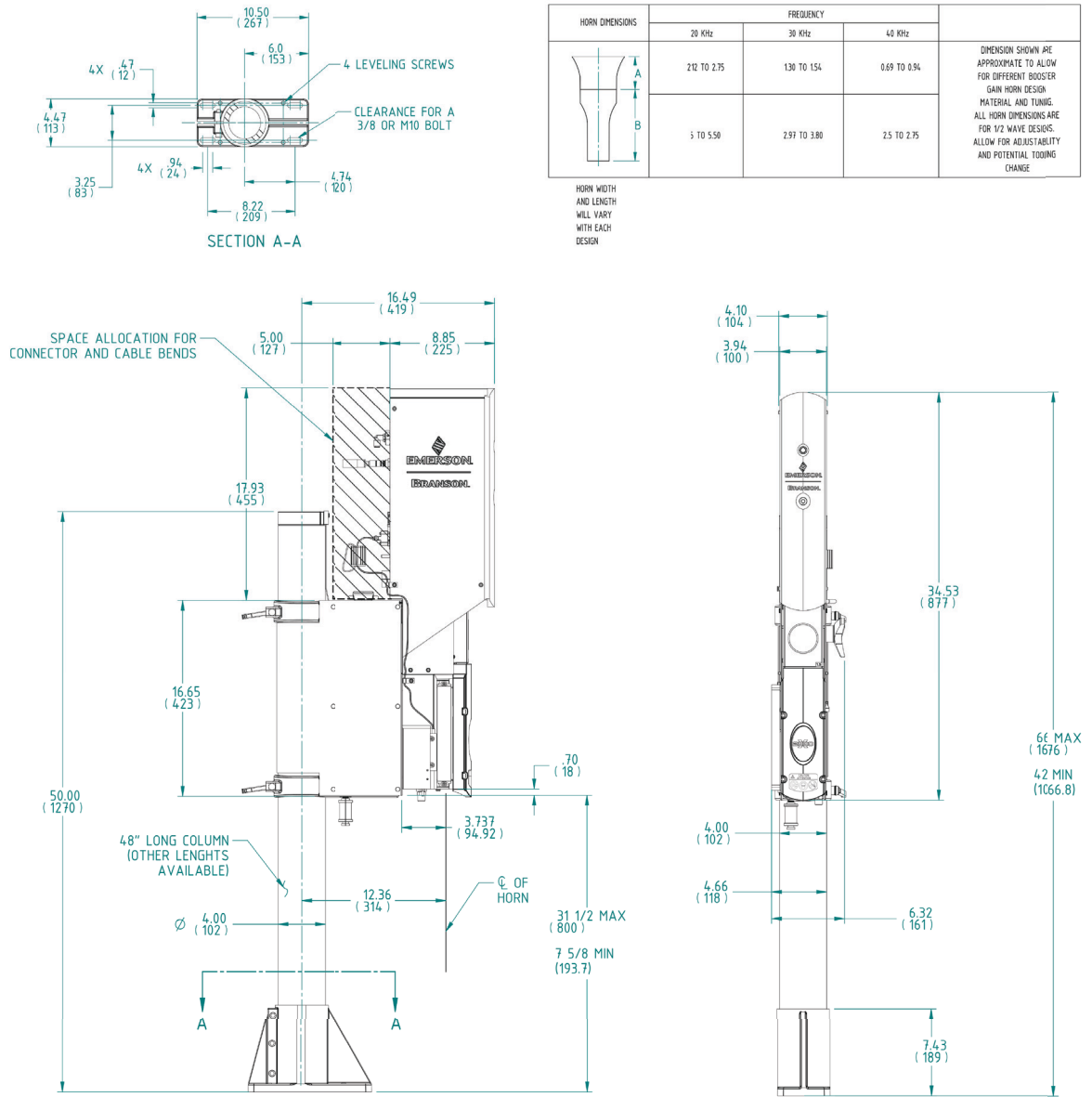
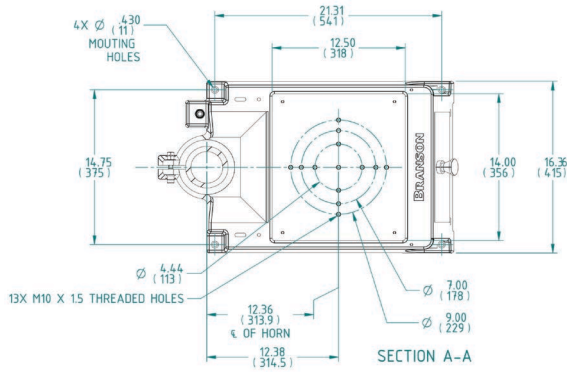

Figure 5.5 2000Xc Series Actuator Dimensional Drawing Hub



Base Mount



HORN DIMENSIONS	FREQUENCY			DIMENSION SHOWN ARE APPROXIMATE TO ALLOW FOR DIFFERENT BOOSTER GAIN HORN DESIGN, MATERIAL AND TUNING. ALL HORN DIMENSIONS ARE FOR 1/2 WAVE DESIGNS. ALLOW FOR ADJUSTABILITY AND POTENTIAL TOOLING CHANGE.
	20 KHz	30 KHz	40 KHz	
	2.12 TO 2.75	1.30 TO 1.54	0.69 TO 0.94	
	5 TO 5.50	2.97 TO 3.80	2.5 TO 2.75	

HORN WIDTH AND LENGTH WILL VARY WITH EACH DESIGN

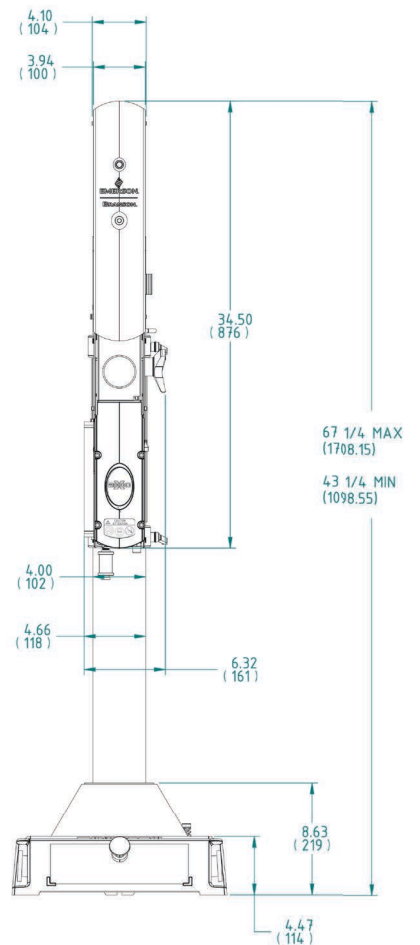
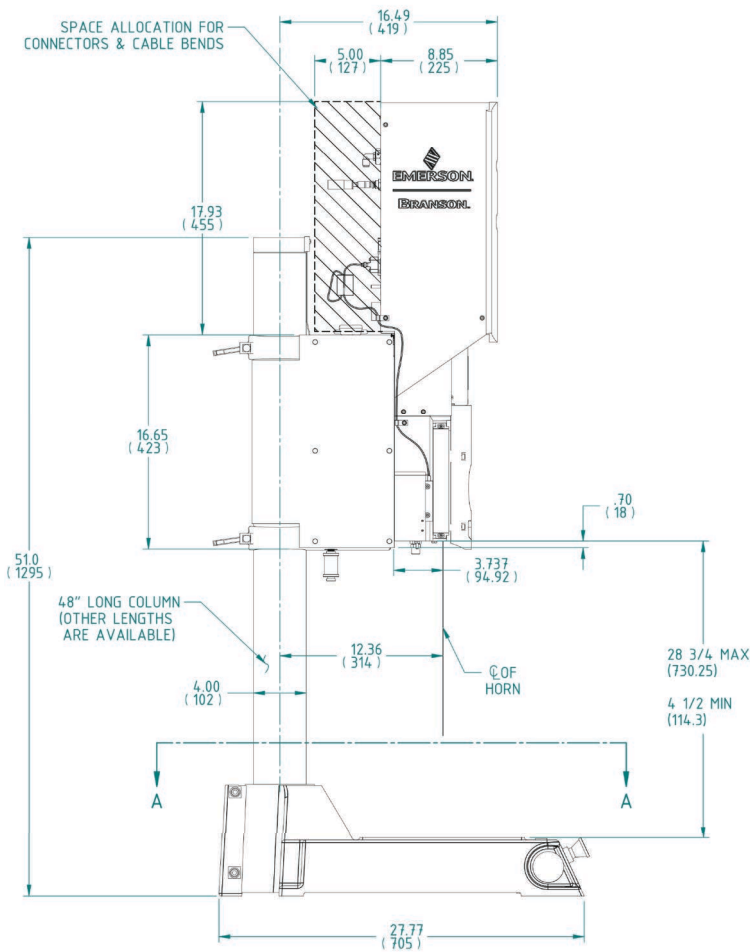

Actuator

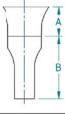
HORN DIMENSIONS	FREQUENCY			DIMENSIONS SHOWN ARE APPROXIMATE TO ALLOW FOR DIFFERENT BOOSTER GAIN HORN DESIGN, MATERIAL AND TUNING. ALL HORN DIMENSIONS ARE FOR 12 WAVE DESIGN. ALLOW FOR ADJUSTABILITY AND POTENTIAL TOOLING CHANGE.
	20 KHz	30 KHz	40 KHz	
	2.02 TO 2.75	1.30 TO 1.54	0.69 TO 0.94	
	5 TO 5.51	2.97 TO 3.80	2.5 TO 2.75	

HORN WIDTH AND HEIGHT VARY WITH EACH DESIGN

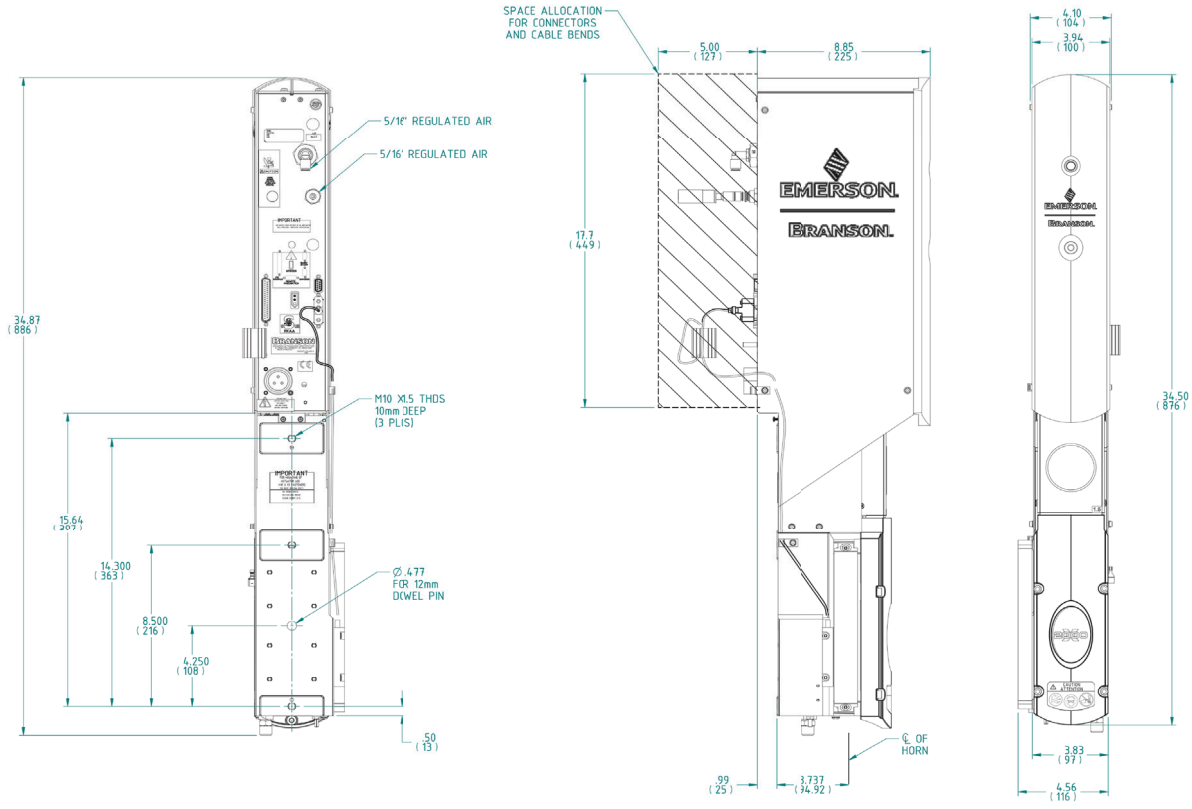

2000Xc AEC Micro Actuator

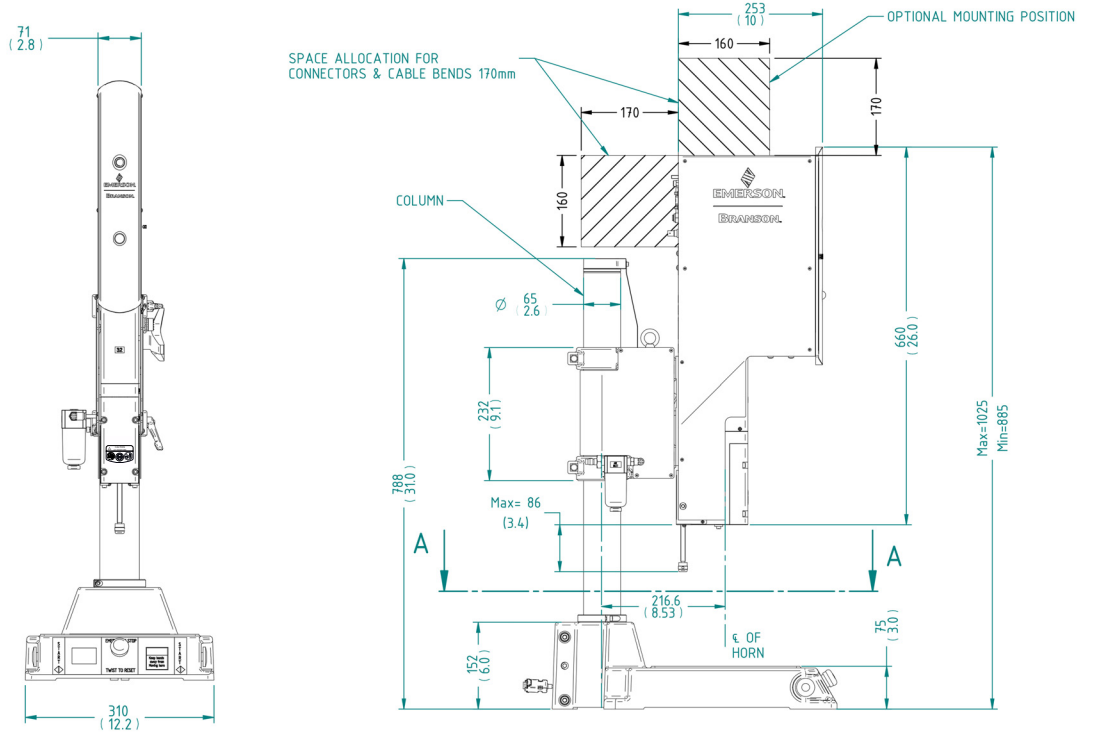
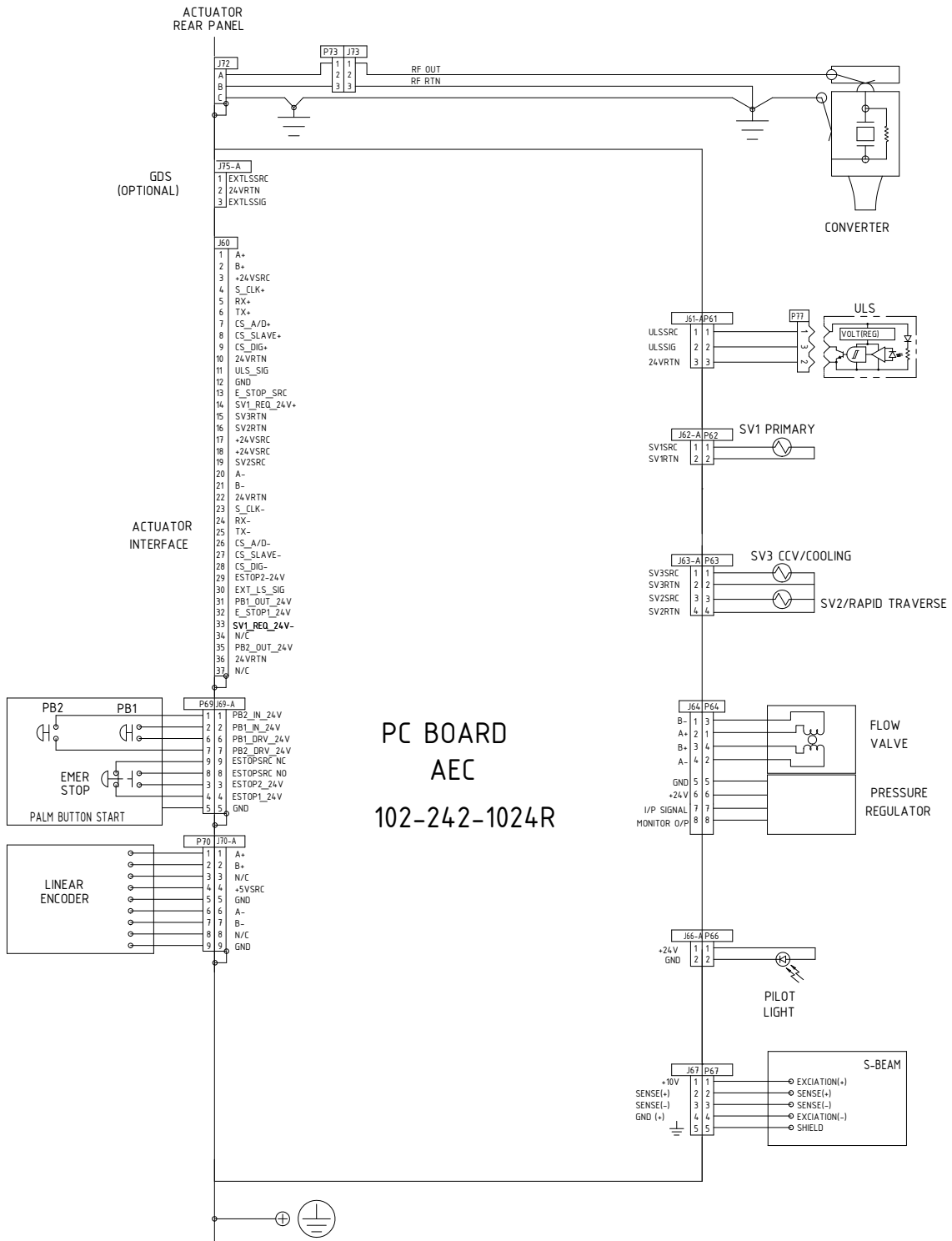

Figure 5.6 Block Wiring Diagram



5.4.2 Environmental Specifications

Table 5.3 Environmental Specifications

Environmental Concern	Acceptable Range
Humidity	30% to 85%, non-condensing
Ambient Operating Temperature	+5° C to +40° C (41° F to 104° F)
IP Rating	2X

5.4.3 Electrical Input Power Ratings

Plug the power supply into a single-phase, grounded, 3-wire, 50 or 60 Hz power source. The current and fuse ratings for the various models, please refer to 2000Xc power supply instruction manual.

The ground screw on the rear of the actuator must be connected to earth ground with #8 gauge wire.

5.4.4 Factory Air

The factory compressed air supply must be “clean (to a 5 micron level), dry and unlubricated” air with a regulated maximum pressure of 100 psig (690 kPa) for 2000Xc AEC actuator and 80 psig (550 kPa) for 2000Xc Micro actuator. Depending on your application, 2000Xc series actuator requires between 35 to 100 psi. Stands include an in-line air filter. Actuators (alone) require a customer-provided air filter. A quick-disconnect fitting is suggested. Use a lockout device on the air line if required.

CAUTION	
	<p>Synthetic air compressor lubricants containing Silicone or WD-40 will cause internal actuator damage and failure due to the solvents contained within these types of lubricants.</p>

5.4.5 Air Filter

Actuators (alone) require a customer-provided air filter which protects from particulate matter of 5 microns or larger.

5.4.6 Pneumatic Tubing and Connectors

Actuator assemblies are not externally plumbed from the factory, but provide conventional 1/4-inch OD pneumatic tubing connection at the air inlet for 2000Xc AEC actuator and Φ 6mm OD pneumatic tubing connection at the air inlet for 2000Xc Micro actuator. If making connections for an actuator, or if re-plumbing your system for a new air filter location, you must use 1/4-inch OD tubing for 2000Xc AEC actuator and Φ 6mm OD for 2000Xc Micro actuator and connectors rated above 100 psi (use Parker "Parflex" 1/4 OD x .040 wall for 2000Xc AEC actuator and Φ 6mmx1mm wall for 2000Xc Micro actuator, type 1, grade E5, or equivalent), and appropriate connectors.

5.4.7 Pneumatic Connections to Actuator

Air connection to the 2000Xc Series Actuator is made to the AIR INLET connector on the top rear of the actuator, with plastic pneumatic tubing. For installations using actuator-alone assemblies, you must provide an air filter assembly which will support at least to 100 psig and remove particulate matter of 5 microns or larger. Refer to [Chapter 4: Technical Specifications](#) for a Pneumatic Schematic.

5.4.8 Air Cylinder Consumption

Table 5.4 Cubic Feet of air per minute per inch of stroke length (each direction)

Air Pressure	1.5"	2"	2.5"	3"	32mm	40mm
10	0.00174	0.00317	0.00490	0.00680	0.00121	0.00189
20	0.00243	0.00437	0.00680	0.00960	0.00170	0.00266
30	0.00312	0.00557	0.00870	0.01240	0.00219	0.00343
40	0.00381	0.00677	0.01060	0.01520	0.00268	0.00419
50	0.00450	0.00800	0.01250	0.01800	0.00318	0.00496
60	0.00513	0.00930	0.01440	0.02080	0.00367	0.00573
70	0.00590	0.01040	0.01630	0.02350	0.00416	0.00649
80	0.00660	0.01170	0.01830	0.02670	0.00465	0.00726
90	0.00730	0.01300	0.02040	0.02910	0.00514	0.00803
100	0.00800	0.01420	0.02230	0.03190	0.00563	0.00879

Use the table above to calculate the air used by the air cylinder.

Add 0.034 cubic foot per second (2CFM) of actual weld time to account for converter cooling air per weld cycle.

Example:

3.0" 2000Xc Series Actuator running at full pressure (100psi) and stroke length (4") at a cycle rate of 20 parts per minute = 0.0319 CFM per inch of stroke (from table) x 8" (total stroke is 4" down and 4" back) equals 0.2552 CFM per stroke.

Weld time is 1 second, so: $0.034 \times 1 = 0.034$ CFM for cooling.

Add 0.2552 CFM for cylinder to 0.034 CFM for cooling equals 0.2892 CFM per cycle.

Multiply by 20 (parts per minute) for a total of 5.784 CFM.

The example above is to be considered a worst case condition for a welder to run at.

The 2000Xc Series Actuator is unique since it's pneumatics are used in a differential mode of operation. For this reason, use the 100psi values from the above table to be on the conservative side for sizing airflow, rather than on the actual force values. Be sure to add the converter cooling value, 0.034.

5.5 Installation Steps

WARNING	
	<p>This product is heavy and can cause a pinching or crushing injury during installation or adjustment. Keep clear of moving parts and do not loosen clamps unless directed to do so.</p>

5.5.1 Mounting the Stand (Actuator on Base)

The base must be bolted to your workbench to prevent tipping or undesired movement. Four mounting bolt holes are provided at the corners of the casting, and will accept your 3/8 inch or M10 cap screws for 2000Xc AEC actuator and M8 cap screws for 2000Xc Micro actuator. Use flat washers against the metal casting to prevent gouging. Refer to [Figure 5.7](#).

CAUTION	
	<p>You must secure the base to your work surface using four bolts, to prevent tipping or undesired movement, in the event the actuator is moved off-center or rotated around the column.</p>

1. Ensure there are no overhead obstructions and that no pinch or rub points exist. Remember that the actuator is taller than the column when fully raised, and there are exposed connections.
2. Mount the base to your workbench using four socket-head cap screws (customer provided, 3/8 inch or M10 for 2000Xc AEC actuator and M8 for 2000Xc Micro actuator). Use flat washers against the metal casting to prevent gouging. The use of nylon lock nuts with your cap screws is suggested, to reduce loosening due to vibration and movement.
3. Connect factory air to the air hose on the stand (3/8 NPT male fitting on the hose). A quick-disconnect fitting is suggested. Use a lockout device on the air line if required.
4. Verify the base/start switch control cable is properly connected to the back of actuator.
5. Verify the linear encoder connector is properly connected to the back of the actuator.
6. Verify earth ground is connected with #8 gauge wire to the ground terminal on the rear of the actuator.

Figure 5.7 Base Mounting Centers
2000Xc AEC Actuator

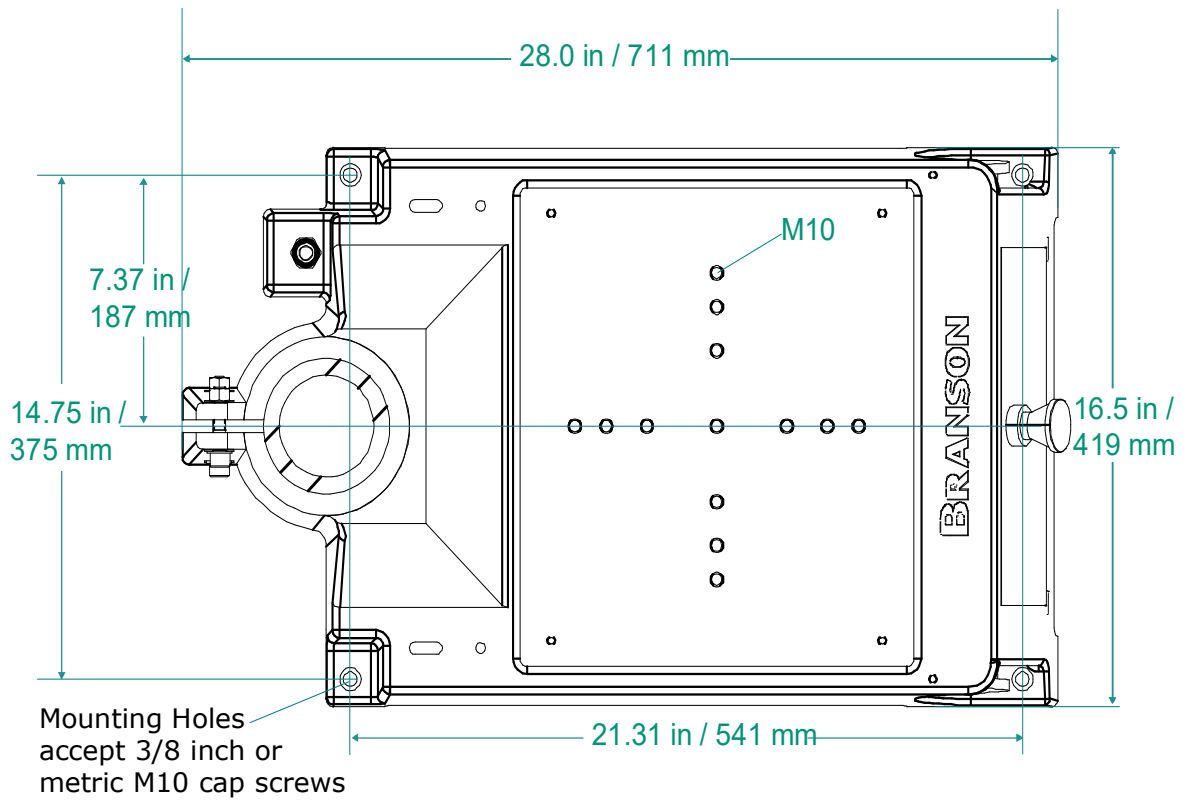

2000Xc Micro Actuator

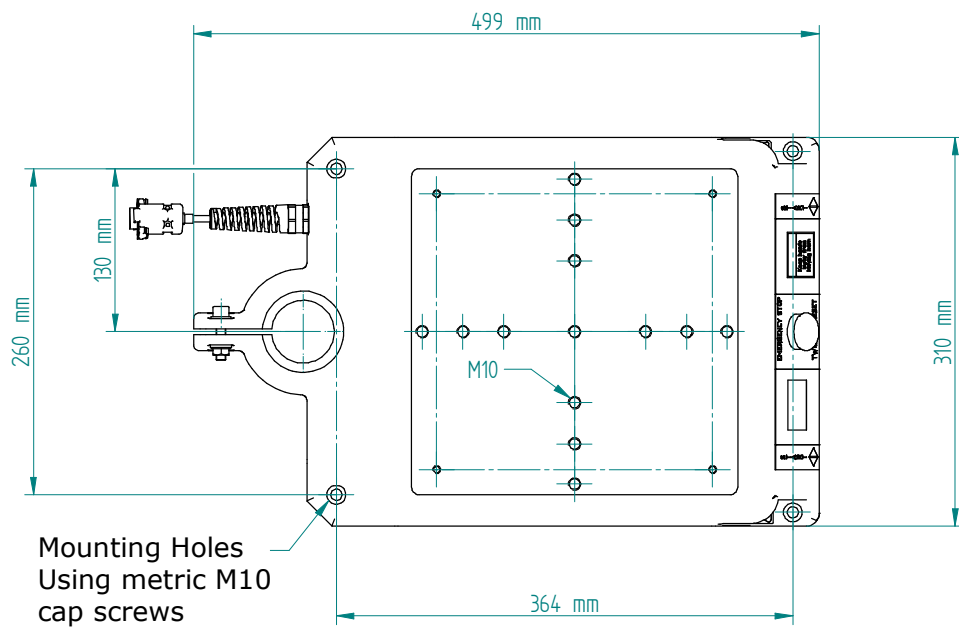

5.5.2 Actuator (Alone)

The actuator (alone) is intended for installation on your custom-made mounting support. It is located in place with a mounting pin and secured using three metric bolts.

CAUTION	
	<p>In a custom installation, the actuator must be mounted on an I-beam or other rigid structure. The mounting surface must be flat within 0.004 in (0.1mm) Total Indicator Reading, in a tolerance zone of 16 x 3.5 in (410 x 90 mm).</p>

1. Lift the actuator from the box. Carefully lay the assembly on its right side (NOT on the side with the linear encoder).
2. Use of a guide pin is suggested. It is not provided with the actuator. If you require a guide pin, use a solid metal dowel pin, 12mm diameter, which must not extend into the actuator more than 0.40 inch (10mm) from your support.

CAUTION	
	<p>The actuator support bolts for the 2000Xc AEC actuator are metric, M10 x 1.5 thread pitch, 25mm long and for the 2000Xc Micro actuator are M8. The support pin and mounting bolts must not extend more than 0.40 in (10 mm) into the actuator, otherwise, binding or damage to the carriage may occur.</p>

CAUTION	
	<p>DO NOT use 900-Series mounting bolts. They have a different thread pitch and will not interchange with those used on the 2000Xc Series.</p>

Figure 5.8 Rear view of Actuator, showing Mounting Surface, Bolt and Guide Pin locations
2000Xc AEC Actuator



Rear view of aec actuator is shown. Although other actuators will vary in height, referenced dimensions will be the same for all models.

**These three mounting surfaces are flat within 0.004 in (0.1 mm) TIR, in a tolerance zone of 16 x 3.5 in (410 x 90 mm). The surface to which the actuator is mounted must also have the same flatness tolerance.

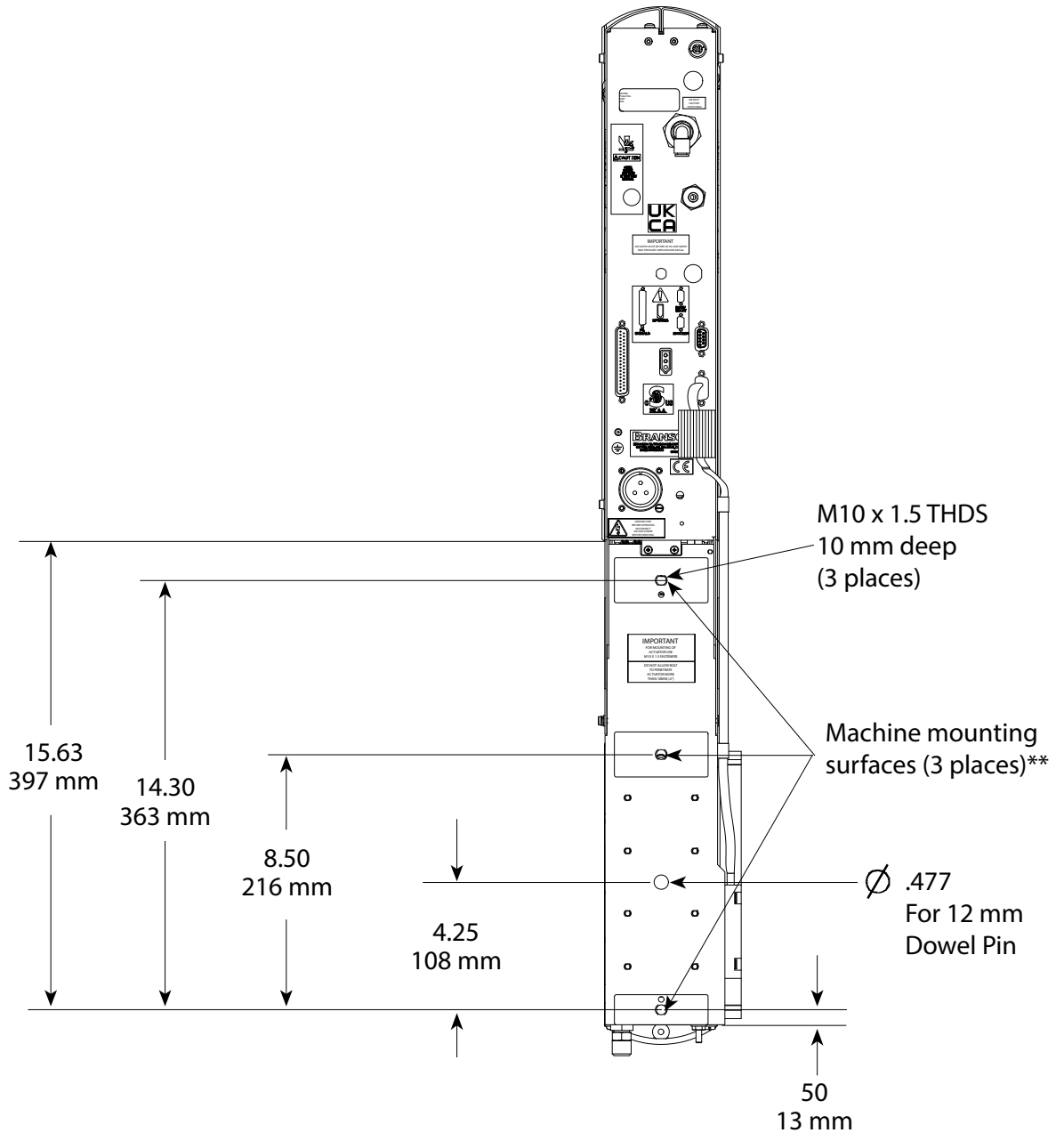
2000Xc Micro Actuator

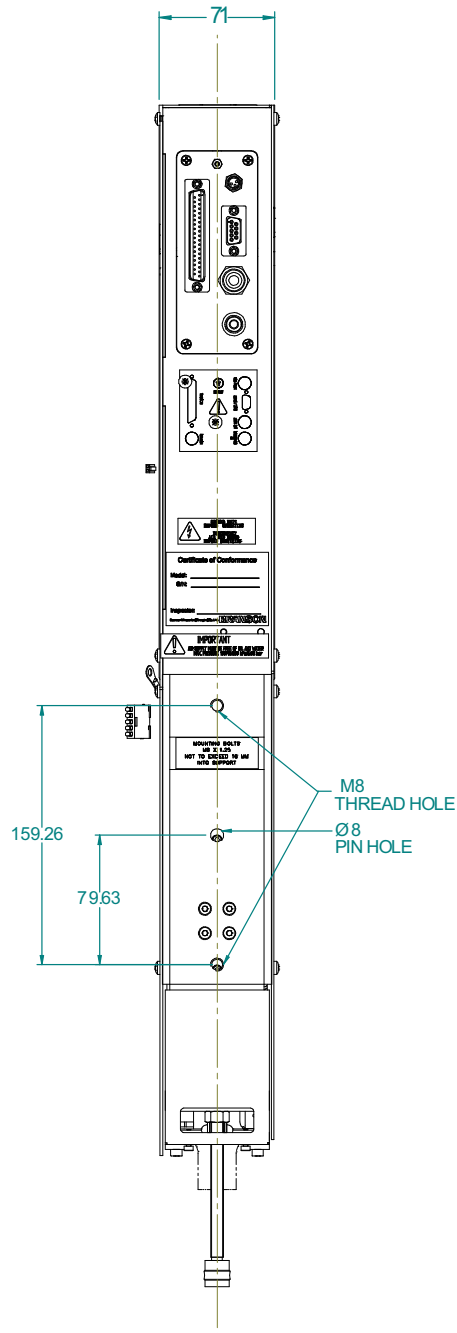

- Lift the actuator assembly into position on your mount, and secure using the metric bolts provided.

CAUTION	
	<p>In the event you must use bolts of a different length, ensure that the bolts extend more than 0.25 inch (6 mm) into the threads in the actuator housing, but less than 0.40 inch (10 mm).</p>

5.5.3 Mount the Power Supply

The power supply is designed to be placed on a workbench (rubber feet on bottom) within cable-length limits of the actuator, or it may be rack-mounted in a standard 19-inch Rack (using an optional rack mount handle kit). It has two rear-mounted fans which draw cooling air from rear to front, which must be free from obstruction. Do not place the power supply on the floor or in other locations that will allow dust, dirt or contaminants to be drawn into the power supply.

The controls on the front of the power supply must be accessible and readable for setup changes.

All electrical connections are made to the rear of the power supply, which should be positioned in your workspace with adequate clearance (approximately 4 inches or more on either side, and 6 inches to the rear) for cable access and ventilation. Do not place anything on top of the power supply case.

In the event the system is to be installed in a high dust environment, the use of a fan filter kit (101-063-614) is required.

See [Figure 5.4](#) for a dimensional drawing of the 2000Xc Series Actuator.

The cable lengths are limited based on the operating frequency of the welding system. Performance and results can suffer if the RF cable is crushed, pinched, damaged or modified. Contact your Branson Representative if you have special cable requirements.

5.5.4 Input Power (Main)

The system requires single-phase input power, which you connect to the power supply using the integral power cord. See [Table 5.4.3](#) for plug and receptacle requirements for your specific power level.

Refer to the unit's Model Data Tag to be sure of the power rating of the Model in your system.

5.5.5 Output Power (RF Cable)

Ultrasonic Energy is delivered to a screw-on MS receptacle connection on the rear of the power supply, which is connected to the actuator or the converter (depending on your application).

WARNING	
	<p>Never operate the System with the RF Cable disconnected or if the RF Cable is damaged.</p>

5.5.6 Interconnect between Power Supply and Actuator

The Branson 2000Xc Series Actuator has two electrical connections between the power supply and the actuator: the RF cable and the actuator interface cable. A 37-pin actuator interface cable is used for power and control signaling between the power supply and actuator. The cable connects to the rear of the power supply and the rear of the actuator.

There can be other connections to the actuator, and other connections to the power supply, but these are the only two standard connections, depicted in [Figure 5.9](#).

For ground detect use, to have ultrasonic energy turn off when the horn comes in contact with your electrically isolated fixture or anvil, it is necessary to install Branson cable EDP No. 100-246-630 from the MPS/GDS receptacle on the rear of the actuator to your isolated fixture/anvil in order to utilize this feature.

Figure 5.9 Electrical Connections from Power Supply to a 2000Xc Series Actuator

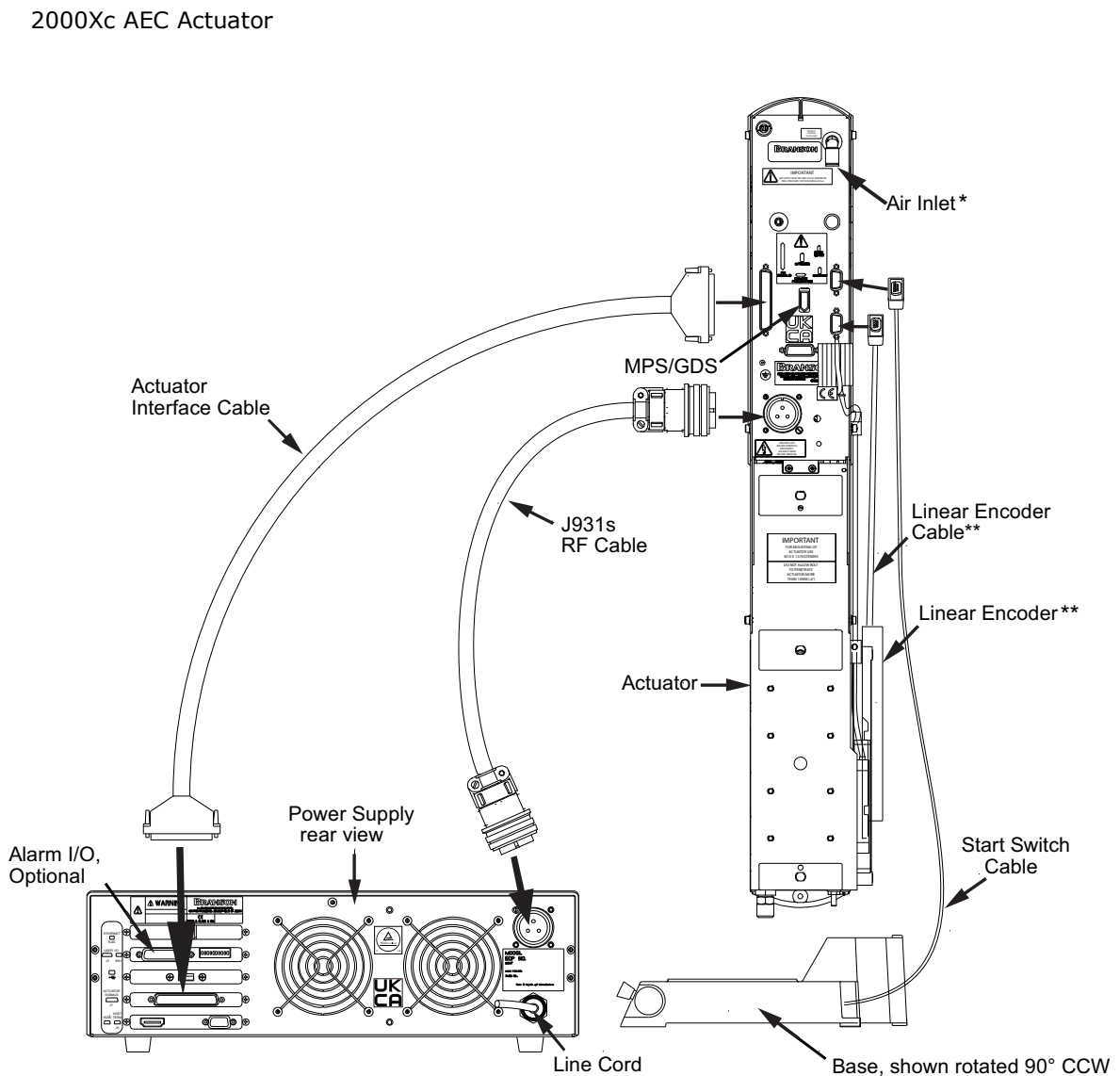

2000Xc Micro Actuator

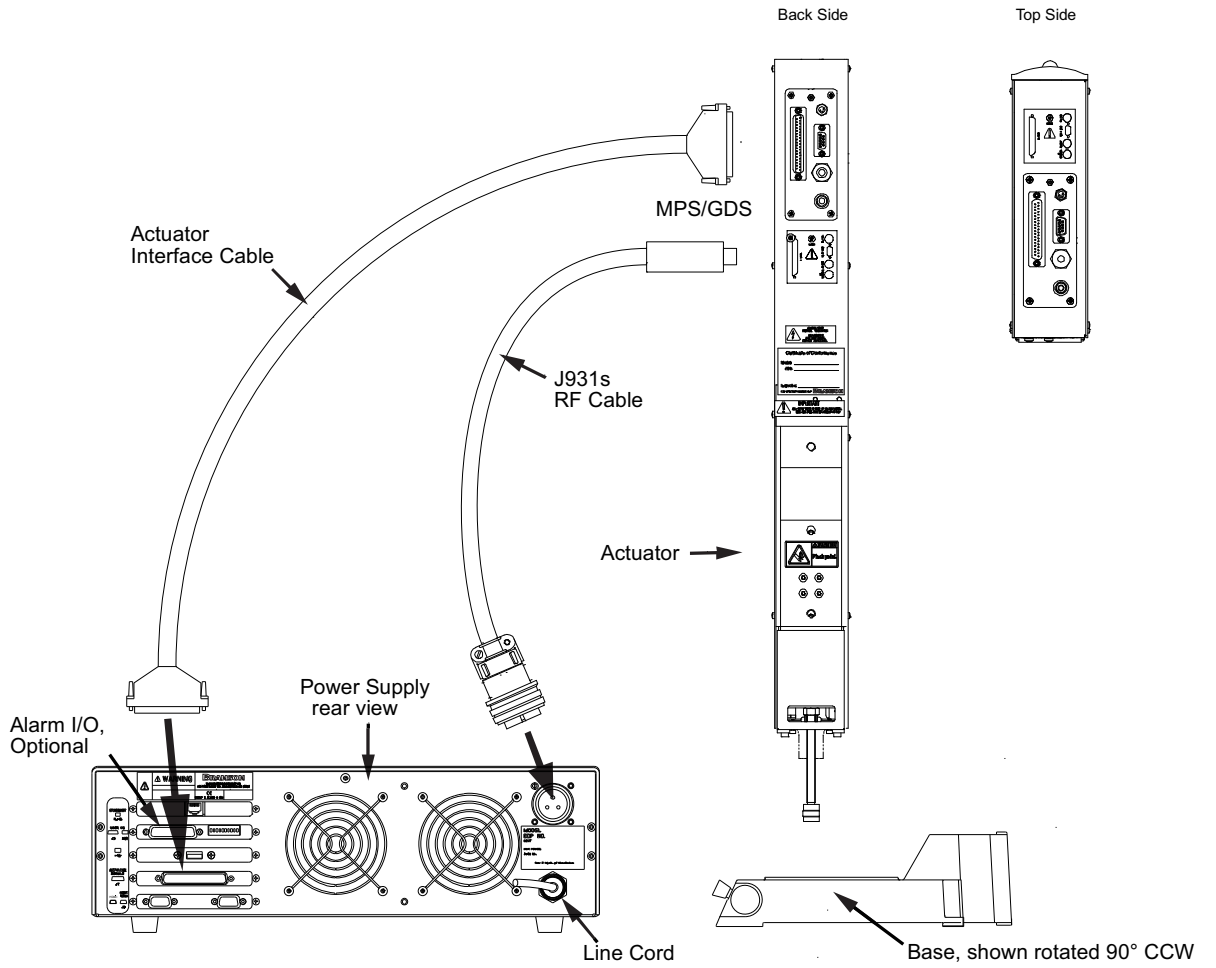

5.5.7 Start Switch Connection

A Branson actuator requires 2 start switches and emergency stop connection. Stands on a base include this connection (factory installed and connected from the base) while the stand on a hub and actuator (alone) applications require the user make their own start switch/E-stop connections, as follows:

Figure 5.10 Start Switch Connection Codes (CE Actuator)

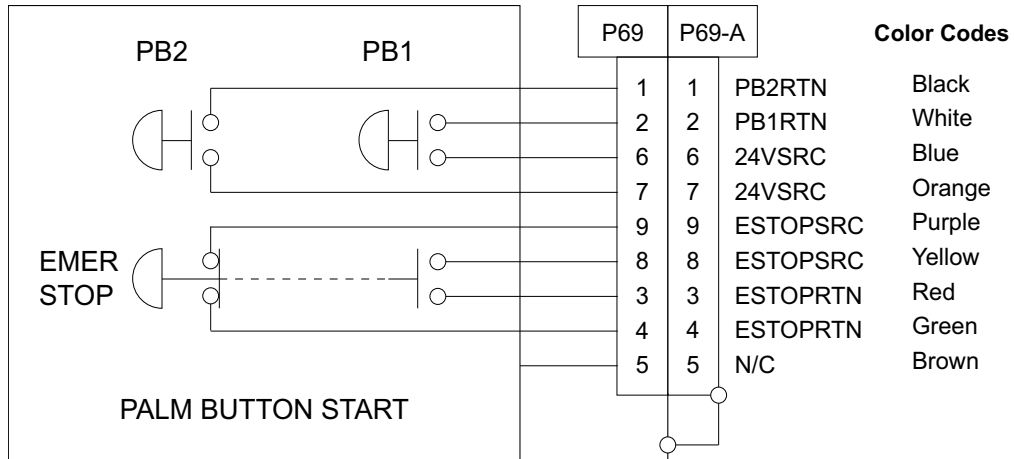

EMER STOP is an emergency stop switch with two contacts: one normally closed, and one normally open.

NOTICE	
	<p>Solid state devices may be used in lieu of mechanical start switches providing their leakage current does not exceed 0.1mA.</p>

NOTICE	
	<p>Start Switches PB1 and PB2 must be closed within 200 milliseconds of each other, and remain closed until the PB Release signal is active, to effect a start condition.</p>

BASE/START is the DB-9 female connection on the back of the actuator. Your cable requires a male DB-9 (D-shell) connector.

PB1 and PB2 are two normally open start-switches which must be operated simultaneously to start the welding cycle. These must be closed within 200 milliseconds of each other, or error message: "Start Sw Time" will display. This doesn't require a reset, but for the next cycle, switches must be within time limit to preclude re-occurrence of error message. Refer to Note above.

NOTICE	
	<p>If you wish to use alternate means to start the welder or as an emergency stop control, you must first have signed a Branson Product Liability Agreement.</p>

5.5.8 User I/O Interface

The user I/O is a standard user interface, provided on the power supply. It provides the ability for the customer to make their own interface for special control or reporting needs. The interface cable has an HD44 female D-shell connection on the rear of the power supply. The electrical interface outputs may be configured for open collector mode or for signal mode (signal voltage levels as indicated), by setting the user I/O DIP switch.

DIP switch SW1 for the user I/O is located next to the J3 on the back of the 2000Xc power supply. User I/O interface cable pinout is listed in [Table 5.5](#).

Figure 5.11 User I/O Cable Identification and Wire Color Diagram

User I/O Cable
Stripped and tinned one end,
HD-44 male connector other end
(cable length as ordered)

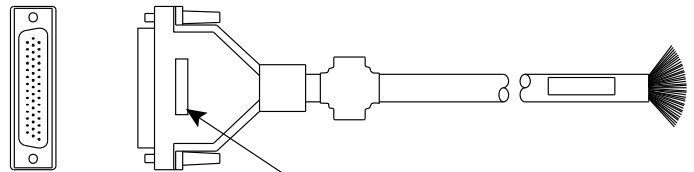

Wire Color Diagram
Two Colors = Insulator/Stripe
Three Colors = Insulator/Stripe/Dot

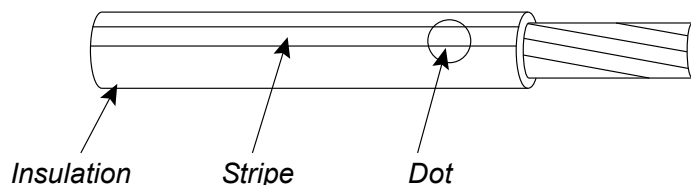

Part number

CAUTION	
	<p>All unused wires must be individually electrically isolated from each other. Failure to properly isolate or incorrect wiring can cause the system controller board to fail.</p>



CAUTION	
	<p>Ensure GND pins and +24 V pins are wired correctly. Failure to properly wire these pins will cause damage to the system controller board.</p>

Table 5.5 User I/O Cable Pin Assignments

Pin	Signal Name	Signal Type	Direction on J3	Colors
1	J3_1_INPUT	24 V Logic 1 True	Input	White/Black
2	CYCLE_ABORT	24 V Logic 1 True	Input	Red/Black
3	EXT_RESET	24 V Logic 1 True	Input	Green/Black
4	SOL_VALVE_SRC	+24 V	Output	Orange/Black
5	REJECT	24 V Logic 0 True	Output	Blue/Black
6	G_ALARM	24 V Logic 0 True	Output	Black/White
7	ACT_CLEAR	24 V Logic 0 True	Output	Red/White
8	J3_8_OUTPUT	24 V Logic 0 True	Output	Green/White
9	MEMORY	Analog	Output	Blue/White
10	USER_AMP_IN	Analog	Input	Black/Red
11	MEM_CLEAR	24 V Logic 0 True	Output	White/Red
12	GND			Orange/Red
13	+24V			Blue/Red
14	G_ALARM_RELAY_1	Relay Contact	Output	Red/Green
15	READY_RELAY_2	Relay Contact	Output	Orange//Green
16	SV1RTN	+24 V return	Input	Black/White/Red
17	J3_17_INPUT	24 V Logic 1 True	Input	White/Black/Red
18	USER_EXT_SEEK+	24 V Logic 1 True	Input	Red/Black/White
19	J3_19_INPUT	24 V Logic 1 True	Input	Green/Black/White
20	SUSPECT	24 V Logic 0 True	Output	Orange/Black/White
21	READY	24 V Logic 0 True	Output	Blue/Black/White
22	J3_22_OUTPUT	24 V Logic 0 True	Output	Black/Red/Green
23	10V_REF	Analog	Output	White/Red/Green
24	AMPLITUDE_OUT	Analog	Output	Red/Black/Green

Table 5.5 User I/O Cable Pin Assignments

Pin	Signal Name	Signal Type	Direction on J3	Colors
25	USER_FREQ_OFFSET	Analog	Input	Green/Black/Orange
26	RUN	24 V Logic 0 True	Output	Orange/Black/Green
27	GND			Blue/White/Orange
28	+24V			Black/White/Orange
29	G_ALARM_RELAY_2	Relay Contact	Output	White/Red/Orange
30	WELD_ON_RELAY_1	Relay Contact	Output	Orange/White/Blue
31	J3_31_INPUT	24 V Logic 1 True	Input	White/Red/Blue
32	J3_32_INPUT	24 V Logic 1 True	Input	Black/White/Green
33	J3_33_INPUT	24 V Logic 1 True	Input	White/Black/Green
34	PB_RELEASE	24 V Logic 0 True	Output	Red/White/Green
35	WELD_ON	24 V Logic 0 True	Output	Green/White/Blue
36	J3_36_OUTPUT	24 V Logic 0 True	Output	Orange/Red/Green
37	PWR	Analog	Output	Blue/Red/Green
38	FREQ_OUT	Analog	Output	Black/White/Blue
39	SEEK	24 V Logic 0 True	Output	White/Black/Blue
40	MEMORY_STORE	Open Collector (Active Low)	Output	Red/White/Blue
41	Analog GND			Green/Orange/Red
42	+24V			Orange/Red/Blue
43	READY_RELAY_1	Relay Contact	Output	Blue/Orange/Red
44	WELD_ON_RELAY	Relay Contact	Output	Black/Orange/Red

CAUTION	
	<p>Ensure all unused wires are properly isolated. Failure to do so may result in power supply or system failure.</p>

NOTICE	
	<p>When syncing multiple systems, refer to the Branson Automation Guide (EDP 100-214-273) for additional information about selection and use of Input and Output features listed in Table 5.6 Input / Output Features.</p>

Table 5.6 Input / Output Features

Input		Output	
	Disabled		Disabled
	Select Preset		Confirm Preset
	Ext U/S Delay		Ext Beeper
J3_1_INPUT	Display Lock		Cycle OK
J3_17_INPUT	Ext Signal	J3_8_OUTPUT	No Cycle Alarm
J3_19_INPUT	Sonics Disable	J3_22_OUTPUT	Overload alarm
J3_31_INPUT	Memory Reset	J3_36_OUTPUT	Modified Alarm
J3_32_INPUT	Ext Tooling		Note
J3_33_INPUT	Sync In		Missing Part
	Part Present		Ext Tooling
	Confirm Reject		Sync Out
			Part-ID Ready

5.5.9 Input Power Plug

If you must add or change the input power plug, use the following color code for the conductors found in the international harmonized line cord. Add the plug that is appropriate for your input power receptacle.

CAUTION	
	<p>The power supply can be permanently damaged if it is connected to the incorrect line voltage, or if the wiring connection is mis-wired. It also presents a safety hazard if mis-wired. Use of the correct plug or connector helps prevent incorrect connections.</p>

Figure 5.12 International Harmonized Line Cord Color Code



5.5.10 User I/O DIP Switch (SW1)

DIP switch SW1, for the user I/O is located next to the J3 on the back of the 2000Xc Series Actuator, as shown in Figure 4.2 Rear View of 2000Xc Power Supply of your power supply manual. The settings of these switches affect the user I/O signals. Factory default setting is for all dip switches is set to ON (closed: switch position closest to number designation).

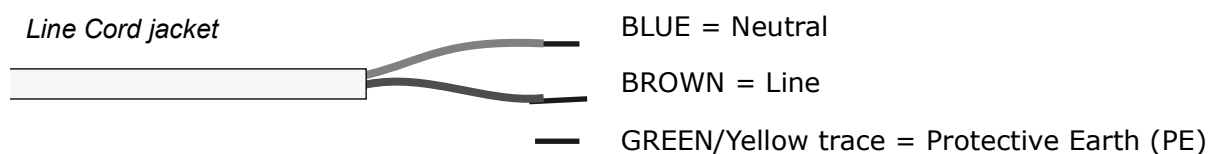
- If the DIP switch is set to the ON (closed) position, the corresponding Output pin will be configured as the current source, 25mA max
- If the DIP switch is set to the OFF (open) position, the corresponding Output pin will be configured as an "open collector", 24VDC, 25 mA max. current sink

Table 5.7 User I/O DIP Switch Functions

Switch Position	Signal Description	Output Signal
1	REJECT_SIG	REJECT
2	SUSPECT_SIG	SUSPECT
3	PB_RELEASE_SIG	PB_RELEASE
4	G_ALARM_SIG	G_ALARM
5	READY_SIG	READY
6	WELD_ON_SIG	WELD_ON
7	ACTUATOR_CLEAR_SIG	ACT_CLEAR
8	J3_22_OUT_SIG	J3_22_OUTPUT
9	J3_36_OUT_SIG	J3_36_OUTPUT
10	J3_8_OUT_SIG	J3_8_OUTPUT

5.6 Guards and Safety Equipment

5.6.1 Emergency Stop Control

If you use the emergency stop button on the actuator to terminate a weld, twist the button to reset it. (The welder will not operate until this button is reset). You must then press Reset at the power supply.

Figure 5.13 Actuator Emergency Stop Button

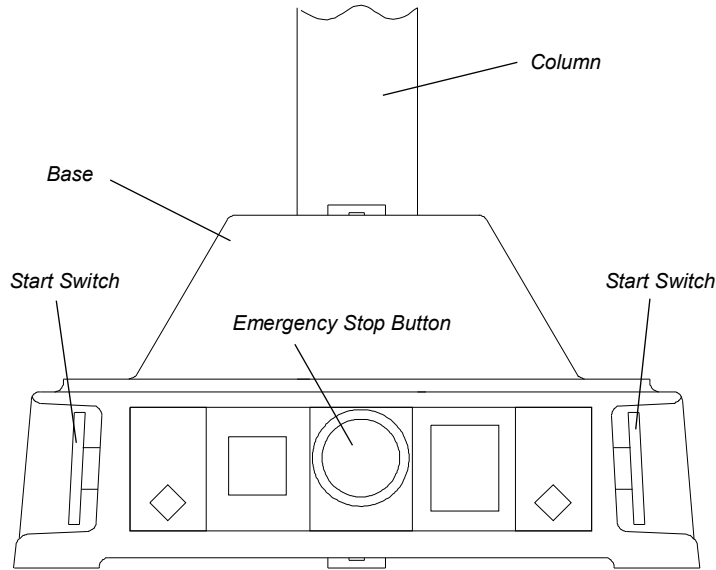

WARNING	
	<p>The Emergency Stop should be engaged prior to removing the door.</p>

- The 2000Xc Series Actuator control system has been designed to conform to the safety requirements of NFPA 79, EN 60204-1, EN ISO 13851, EN ISO 13850, and CFR 1910.212.
- Two Hand Control of the 2000Xc Series Actuator control system has been designed to comply with Type 3 of NFPA, Type III of EN 60204-1, and EN ISO 13851.
- The Emergency Stop functions as a category 0 stop of NFPA 79, EN ISO 13850, and EN 60204-1.

NOTICE	
	<p>Emergency Stop function should be tested every 8760 hours.</p>

5.7 Rack Mount Installation

If the system is Rack Mounted, you need to order the Rack Mount handle kit. The kit includes two rack mounting handles and two corner pieces, which support the handles and provide the rack mount interface.



CAUTION	
	<p>The Rack Mount handle kit does NOT support the power supply in the rack. The weight of the power supply must be supported by integral brackets of the rack itself.</p>
NOTICE	
	<p>Do not permanently remove the cover from the power supply because it is required for proper system cooling.</p>

Figure 5.14 Detail of Rack Mount Handle Kit Assembly

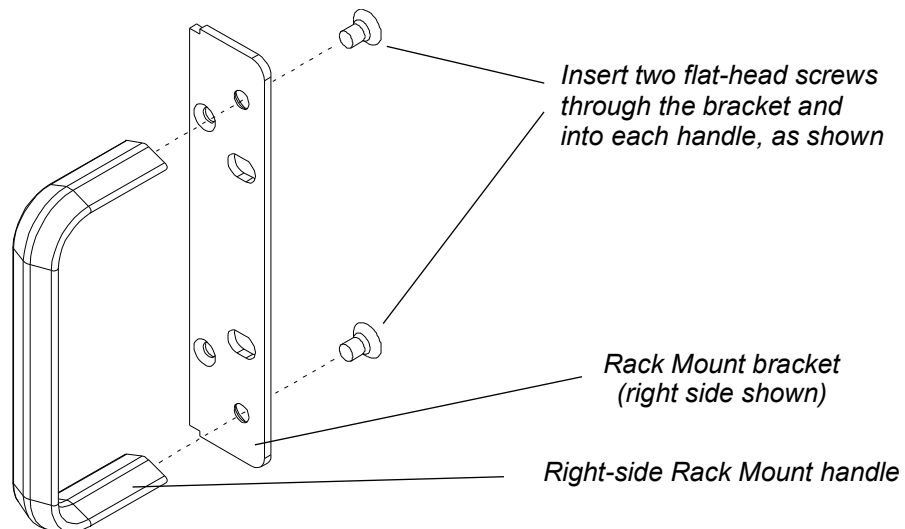



Table 5.8 Rack Mount Installation

Step	Procedure
1	Order and obtain the rack mount kit for your power supply. The brackets in the kit are designed for standard 19-inch rack mounting options.
2	From the front corners of the power supply, remove the corner trim pieces by removing the two Phillips screws. Save the screws.

Table 5.8 Rack Mount Installation

Step	Procedure
3	Noting that one side of each bracket is countersunk to accept the provided flathead screws, assemble the Rack Mount Handles as shown in Figure 5.14 . (This shows only the Right bracket and handle; the left side is a mirror-image). Tighten the screws securely and so they are flush.
4	Re-using the screws you removed in Step 2, install the assembled Handle in place of the Front Corner pieces.
5	Save the removed hardware corner pieces.
6	When you are ready to install the unit, use the hardware from your Rack Mounting system to locate the power supply.

5.8 Assemble the Acoustic Stack

CAUTION	
	<p>The following procedure must be performed by a setup person. If necessary, secure the largest portion of a square or rectangular horn in a soft jawed (brass or aluminum) vise. NEVER attempt to assemble or remove a horn by holding the converter housing or the booster clamp ring in a vise.</p>

CAUTION	
	<p>Do not use silicone grease with Mylar washers. Use only 1 (one) Mylar washer of the correct inside and outside diameters at each interface.</p>

CAUTION	
	<p>No Mylar washers for 40 kHz. Use silicone grease for 40 kHz.</p>

Table 5.9 Tools, Grease and Mylar Washers

Tool	EDP Number
20, and 30 kHz Torque Wrench Kit	101-063-787
40 kHz Torque Wrench	101-063-618
20 kHz Spanner Wrench	101-118-039
30 kHz Spanner Wrench	201-118-033
40 kHz Spanner Wrench	201-118-024
Silicone Grease	101-053-002
Kit 20 kHz, 10 each (1/2 in. and 3/8 in.)	100-063-357
Kit 20 kHz, 150 each (1/2 in.)	100-063-471
Kit 20 kHz, 150 each (3/8 in.)	100-063-472
Kit 30 kHz, 10 each (3/8 in., 30 kHz)	100-063-632

5.8.1 For a 20 kHz System

Table 5.10 For a 20 kHz System

Step	Action
1	Clean the mating surfaces of the converter, booster, and horn. Remove any foreign material from the threaded holes.
2	Install the threaded stud into the top of the booster. Torque to 450 in-lbs, 50.84 Nm. If the stud is dry, apply 1 or 2 drops of a light lubricating oil before installing.
3	Install the threaded stud into the top of the horn. Torque to 450 in-lbs, 50.84 Nm. If the stud is dry, apply 1 or 2 drops of a light lubricating oil before installing.
4	Install a single Mylar washer (matching the size of the washer to the stud) to each interface.
5	Assemble the converter to the booster and the booster to the horn.
6	Torque to 220 in-lbs, 24.85 Nm. (Torque 20 kHz Solid Mount Converter to 250 in-lbs, 28.25 Nm).

5.8.2 For a 30 kHz System

Table 5.11 For a 30 kHz System

Step	Action
1	Clean the mating surfaces of the converter, booster, and horn. Remove any foreign material from the threaded holes.
2	Apply a drop of Loctite®* 290 thread-locker (or equivalent) to the studs for the booster and horn
3	Install the threaded stud into the top of the booster; torque to 290 in-lbs, 32.76 Nm, and let cure for 30 minutes.
4	Install the threaded stud into the top of the horn; torque to 290 in-lbs, 32.76 Nm, and let cure for 30 minutes.
5	Install a single Mylar washer (matching the size of the washer to the stud) to each interface.
6	Assemble the converter to the booster and the booster to the horn.
7	Torque to 185 in-lbs, 21 Nm.

*Loctite is a registered trademark of Henkel Corporation, U.S.A.

5.8.3 For a 40 kHz System

Table 5.12 For a 40 kHz System

Step	Action
1	Clean the mating surfaces of the converter, booster, and horn. Remove any foreign material from the threaded holes.
2	Apply a drop of Loctite®* 290 thread-locker (or equivalent) to the studs for the booster and horn.
3	Install the threaded stud into the top of the booster; torque to 70 in-lbs, 7.91 Nm, and let cure for 30 minutes.
4	Install the threaded stud into the top of the horn; torque to 70 in-lbs, 7.91 Nm, and let cure for 30 minutes.
5	Coat each interface surface with a thin film of silicon grease – but do not apply silicon grease to a threaded stud or tip.
6	Screw the converter to the booster.
7	Torque to 95 in-lbs, 10.73 Nm.
8	Slide the booster/horn assembly into the adapter sleeve. Screw on the adapter sleeve ring nut and leave loose.
9	Screw the booster onto the horn.
10	Repeat Step 7.
11	Securely tighten the adapter sleeve ring nut with the spanner wrenches shipped with the sleeve assembly.

*Loctite is a registered trademark of Henkel Corporation, U.S.A.

5.8.4 Assembling the Acoustic Stack

Figure 5.15 Assembling the 20 kHz Acoustic Stack

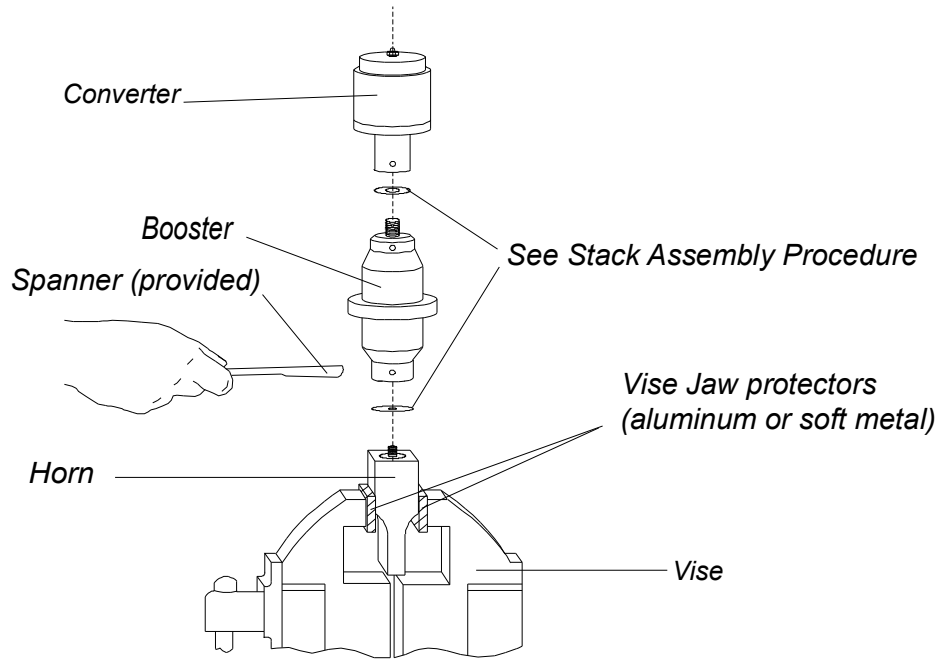

NOTICE	
	<p>The use of a Branson torque wrench or the equivalent is recommended. P/N 101-063-787 for 20, and 30 kHz systems and 101-063-618 for 40 kHz systems.</p>

Table 5.13 Stud Torque Values

Used On	Stud Size	Torque	EDP #
20 kHz	1/2" x 20 x 1-1/4"	450 in.-lbs, 50.84 Nm.	100-098-370
20 kHz	1/2" x 20 x 1-1/2"	450 in.-lbs, 50.84 Nm.	100-098-123
30 kHz*	3/8" x 24 x 1"	290 in.-lbs, 32.76 Nm.	100-298-170R
40 kHz*	M8 x 1.25	70 in.-lbs, 7.91 Nm.	100-098-790

*Add a drop of Loctite 290 threadlocker to the stud. Torque and let cure for 30 minutes before use.

5.8.5 Connecting Tip to Horn

1. Clean the mating surfaces of the horn and tip. Remove foreign matter from the threaded stud and hole.
2. Hand assemble the tip to the horn. Assemble dry. Do not use any silicone grease.
3. Use the spanner wrench and an open-end wrench (refer to figure below) and tighten to the Torque tip specifications in [Table 5.15](#).

Figure 5.16 Connecting Tip to Horn

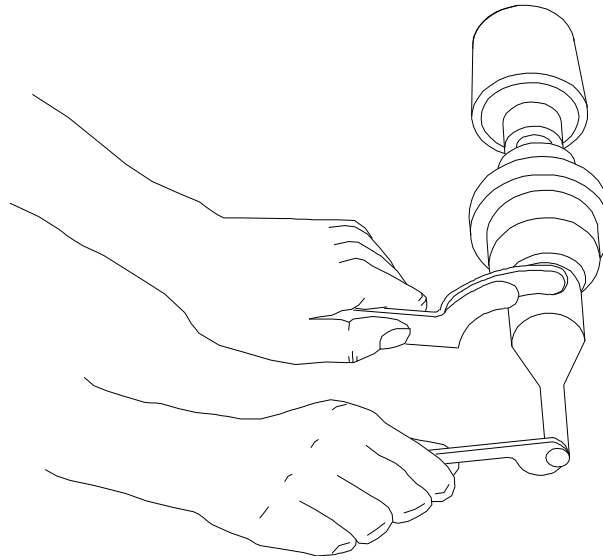

Table 5.14 Tip to Horn Torque Specifications

Tip Thread	Torque
1/4 - 28	110 in.-lbs, 12.42 Nm.
3/8 - 24	180 in.-lbs, 20.33 Nm.

5.8.6 Installing the Ultrasonic Stack in the Actuator

20 kHz and 30 kHz Converter Stacks

The ultrasonic stack must first be assembled. To install the stack:

1. Make sure that the system power is turned off by disconnecting the power plug.
2. Engage the Emergency Stop.
3. Loosen the four door screws.
4. Pull the door straight off and set it aside.

CAUTION	
	<p>It is recommended to do a risk assessment of the tooling according to its design to prevent any damage, such as dropping a heavy tooling, or cutting your hands, when installing the stack in the actuator.</p>

5. Take the assembled ultrasonic stack and align the ring on the booster just above the support washer in the carriage. Firmly push the stack into place, with the acorn nut on the top of the converter making contact with the contactor in the top of the carriage.
6. Reinstall the door assembly, and start the four door screws.
7. Align the horn by rotating it, if necessary. Torque the carriage door to 20 in.-lbs to secure the stack.

Figure 5.17 Installing a 20 kHz Stack in 2000Xc AEC Actuator

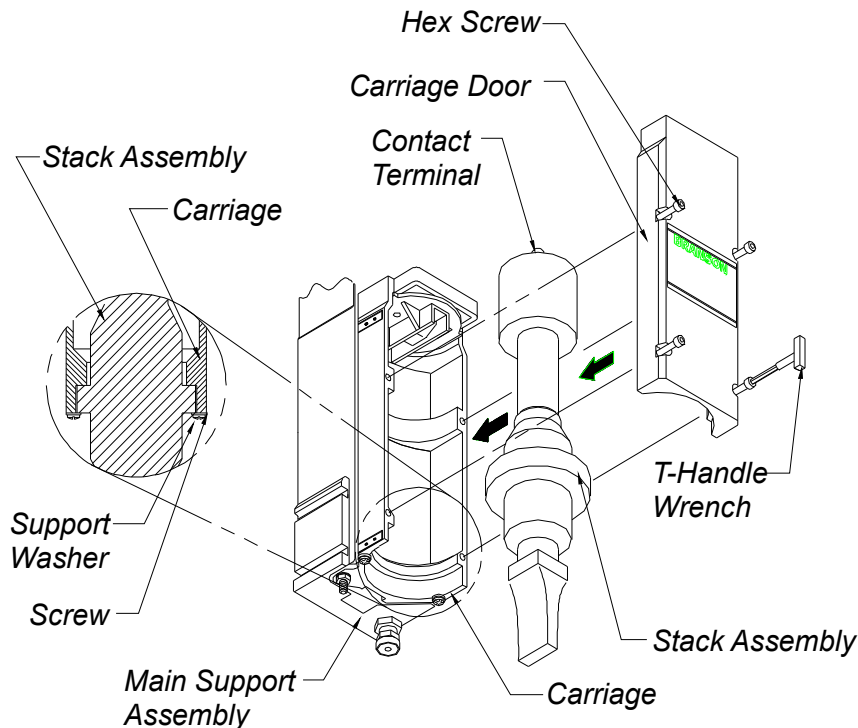

40 kHz Converter Stacks

1. Make sure that the system power is turned off by disconnecting the power plug.
2. Place the converter / booster in the sleeve.
3. Loosen the four carriage door screws.

Figure 5.18 Installing a 40 kHz Stack in 2000Xc AEC Actuator

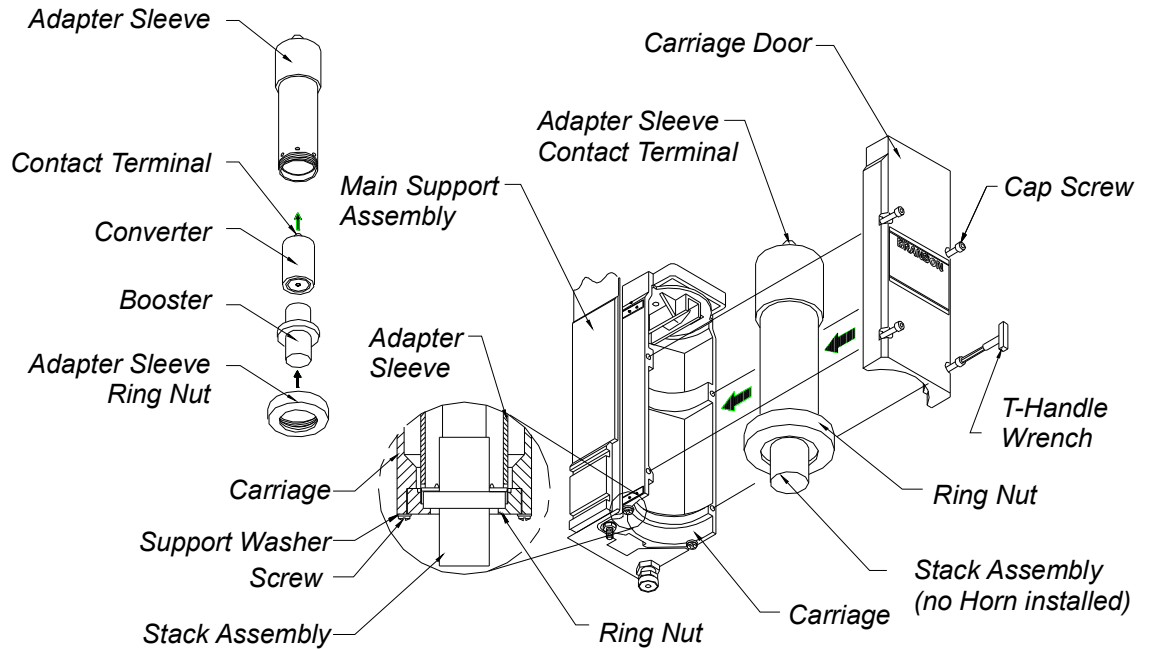
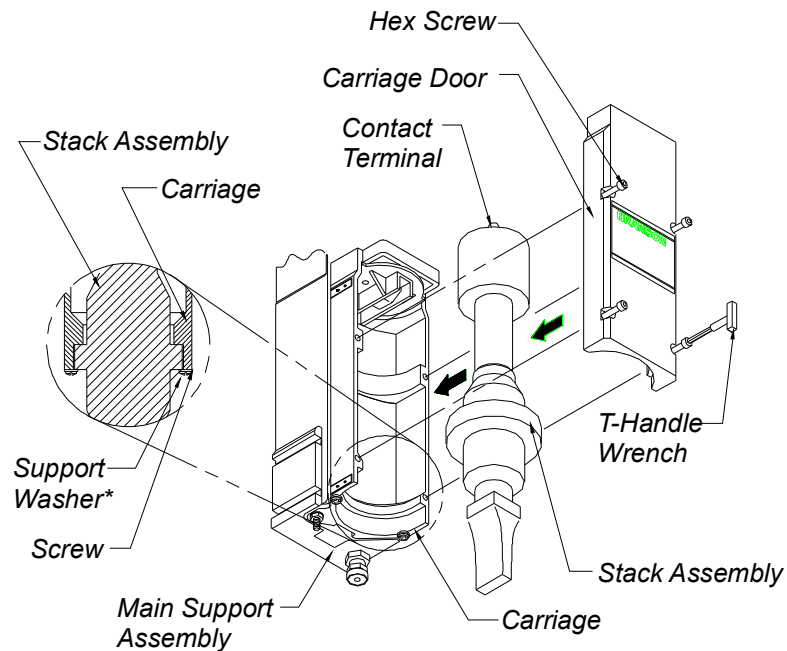



Figure 5.19 Installing a 40 kHz Stack in 2000Xc Micro Actuator



Note: * Using solid mount booster requires special support washer (EDP No: 109-114-243).

4. Pull the door straight off and set it aside.

CAUTION	
	Do not attempt to hold the sleeve in a vise. It can be easily crushed or damaged.

5. Take the assembled sleeve and align the ring nut on the booster just above the support washer in the carriage. Firmly push the sleeve into place, with the acorn nut on the top of the converter making contact with the contactor in the top of the carriage.
6. Reinstall the door assembly, and start the four door screws.
7. Align the horn by rotating it, if necessary. Torque the carriage door to 20 in.-lbs to secure the stack.

5.9 Mounting the Fixture on the Base Hardware and mounting holes

The base provides mounting holes for your fixture. Mounting holes are also provided for the optional Branson leveling plate kit. The base is tapped for metric M10-1.5 hardware. The mounting holes are arranged in three concentric bolt circles with the following dimensions.

CAUTION	
	<p>The base is cast metal and the mounting holes can become stripped if the hardware is overtightened. Tighten your hardware only enough to prevent movement of your fixture.</p>

Figure 5.20 Mounting Holes on Base
2000Xc AEC Actuator



The optional guard, EDP 101-063-550, (sometimes required with very large horns) is shown for position only. It extends several inches to either side of the base, and prevents the user from operating the welder and pinching their fingers or hands between the base and the tooling.

2000Xc Micro Actuator

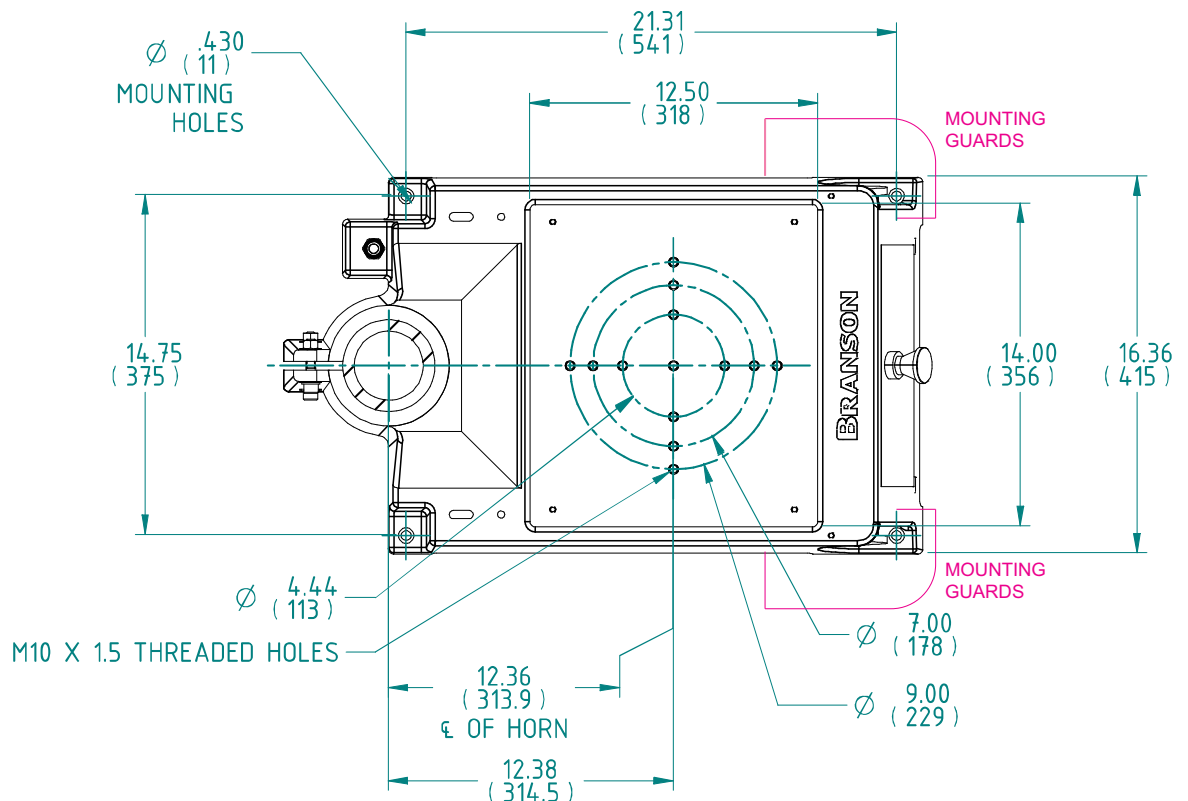
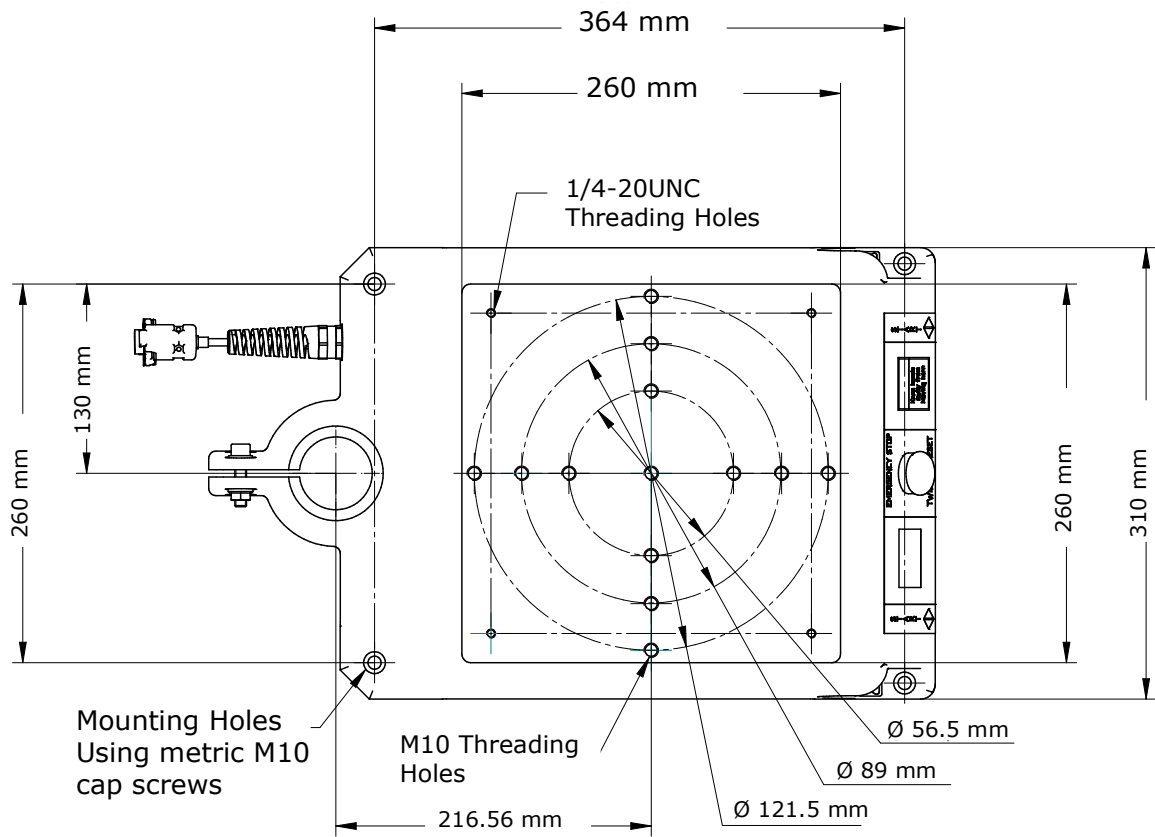

5.10 Testing the Installation

1. Turn on the air supply connections including the pneumatic dump valve and verify that the air pressure indicator light in the actuator is lit.
2. Ensure there are no leaks in the air supply connections.
3. Turn on the power supply. The power supply will begin its normal self-check.
4. If the power supply displays an alarm message other than Recalibrate Actuator, find the alarm message definition, cause and correction in Chapter 7: Actuator Operation of your power supply manual. If the power supply displays the alarm message Recalibrate Actuator, go on to the next step.
5. Perform an actuator calibration by touching the Main Menu button, and then press the Calibration button. Verify that there is a minimum clearance from horn face to workpiece greater than 0.70".
6. Touch Cal Actuator.
7. In the screen that follows, touch w/Start Switches.
8. Press the Start switches to complete the calibration.
9. Press the Test button.
10. If the power supply displays an alarm message at this point, find the alarm message definition in Appendix B: Alarms of your power supply manual. If there are no alarm messages displayed, go on to the next step.
11. Fit a test part onto the fixture.
12. Touch Horn Down on the Main Menu and press the palm buttons. The horn will descend to the fixture on the base of the actuator. This verifies specifically that the pneumatic system is working.
13. Press the Retract button. The horn will retract. The system should now be functional and can be set up for your application.

In summary, if the power supply does not display an alarm message and descends and retracts correctly, your ultrasonic welder is ready for operation.

Figure 5.21 Front Panel Display

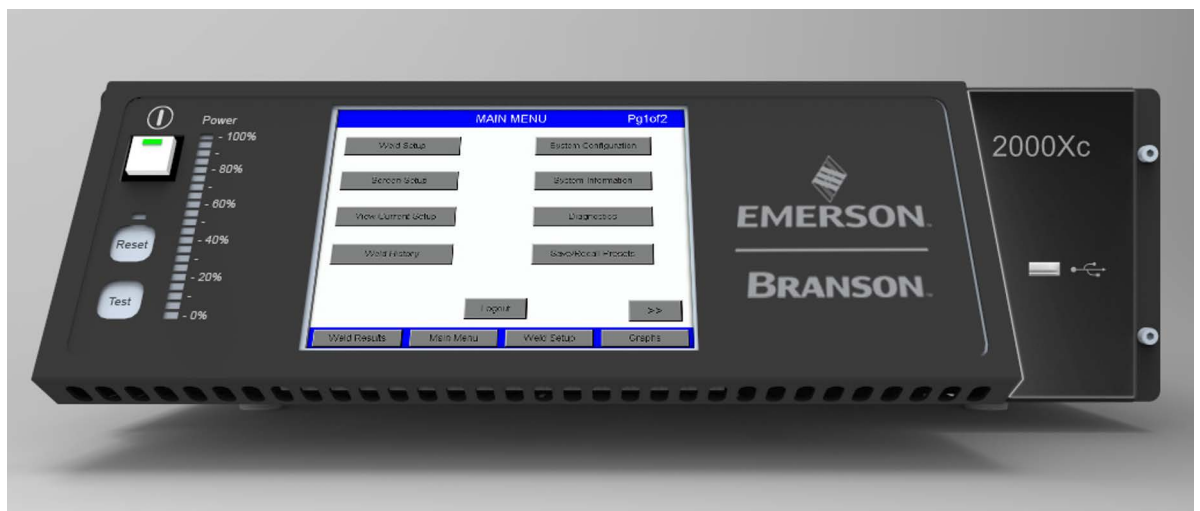

5.11 Still Need Help?

Branson is pleased that you chose our product and we are here for you! If you need parts or technical assistance with your 2000Xc Series Actuator system, call your local Branson representative or contact Branson customer service by calling the appropriate department as indicated in [1.4 How to Contact Branson](#).

Chapter 6: Actuator Operation

6.1	Actuator Controls	98
6.2	Initial Actuator Settings	99
6.3	Operating the Actuator	104
6.4	Safety Circuit Alarms	105

6.1 Actuator Controls

This section describes how to operate a weld cycle using the 2000Xc Series Actuator. For more detailed information on making and altering settings, refer to your 2000Xc Power Supply manual.

WARNING	
	<p>When setting up and operating the Actuator, observe the following precautions:</p> <p>Keep hands away from under the horn. Down force (pressure) and ultrasonic vibrations can cause injury.</p>

CAUTION	
	<p>Plastic parts can vibrate within the audible frequency range when welded. If this occurs, use hearing protectors to prevent possible injury. Do not allow the ultrasonically activated horn to touch a metal base or a metal fixture.</p>

The 2000Xc Series Actuator is controlled by the Power Supply. The Actuator sends operating cycle data (such as velocity and force), status information, and alarm information to the Power Supply. The Power Supply sends operating parameters to the Actuator, determining how and when weld cycles are initiated and terminated. The Actuator passes distance, force, and pressure information continuously to the Power Supply.

WARNING	
	<p>When using larger horns, avoid situations where fingers could be pinched between the horn and the fixture. Contact Branson for information on an optional guard.</p>

CAUTION	
	<p>Wear Safety glasses to protect your eyes from debris and dust.</p>

6.2 Initial Actuator Settings

The Actuator is controlled by the Power Supply, however there are several functions that are part of the Actuator. These include:

- Factory Air Source
- Mechanical Stop
- Actuator Position and Height above fixture (Horn travel)
- Emergency Stop (on Base, and provided as a User I/O signal for automation)

Each of these will affect the operation of the Actuator.

6.2.1 Regulated Air Pressure and Air Pressure Indicator

When factory air is present, it is delivered to the regulator located in the actuator.

CAUTION	
	<p>When factory air is removed from the system, or the dump valve is activated, the Actuator may “settle” to a lower position, since it is held up by the constant air pressure. Be sure to keep your hands and fingers from under the Horn or other pinch points, and use a block of wood or other soft material to block the Horn up to prevent damage to the tooling.</p>

Set the air to a low pressure setting. In the event something is incorrectly connected, a low air pressure setting will reduce any sudden movement. A typical initial setting is approximately 20-25 psi for a new or unproven setup.

CAUTION	
	<p>Permanent damage to the system and possible injury can result if the Actuator is supplied with factory air above the maximum indicator reading of 100 psig (690 kPa). Set the pressure regulator to zero before connecting or disconnecting the factory air supply.</p>

6.2.2 Factory Air Source

Factory air must be turned on, supplying the actuator's air pressure regulator with air pressure. If factory air is too low (below 35 psi maintained) the actuator will not weld or operate reliably. Factory air is also used to provide cooling air to the converter.

Factory air input may affect weld results for applications requiring more weld pressure buildup.

NOTICE	
	<p>Factory Air pressure must be greater than the maximum system requirements. The compressed air system must have sufficient capacity to serve all of the systems connected to it. The use of an accumulator may be required to provide continuous air flow.</p>

6.2.3 Downspeed Control

The Downspeed Control regulates the horn velocity. Downspeed has a significant effect on the force buildup on the workpiece, and hence the quality of the weld.

NOTICE	
	<p>Set velocity to 1-2"/sec, for an initial setup.</p>

6.2.4 Actuator Alignment and Height (Horn Travel)

The horn carriage will travel up and down on the actuator's slides. The actuator can also be adjusted up or down on the column. The distance between the fixture and horn should allow easy and ready access and removal of your parts.

- Minimum stroke cannot be less than 1/8"
- Maximum stroke cannot exceed 3-3/4" before part contact to allow for the operation of the dynamic flow through mechanism

Consistent weld results are best measured when the horn travel is more than 1/4 inch, because a shorter distance can be affected by other components of the welding system and a suitable build-up of pressure on the parts.

6.2.5 Mechanical Stop

For 2000Xc AEC actuator

The Mechanical Stop affects the amount of downward travel the Actuator is allowed to have, up to the full stroke length of the unit. The multi-turn knurled knob to the right of the Stack, on the bottom of the Actuator, is the Mechanical Stop adjustment. The Mechanical Stop has an indicator on the right side of the Actuator, showing a scale of an arbitrary unit of measure.

The Mechanical Stop is designed to stop the Horn from contacting your Fixture in the event your part is missing. It is not a precision measuring device, and it is usually not recommended that this be used as a 'collapse' or other distance weld limiting device. The "missing part" function can also be used to control critical horn to fixture distances.

CAUTION	
	This equipment is designed to be operated by one (1) person only.

Initially, set the mechanical stop to allow at least 1/4 inch of Horn travel, but any distance up to the full stroke length is suitable.

To adjust the Mechanical Stop

Table 6.1 To adjust Mechanical Stop of 2000Xc AEC Actuator

Step	Action
1	Activate the manual dump valve and manually lower the carriage until the horn is just above the fixture.
2	If the horn does not reach the fixture and has not traveled 4 inches (100 mm), loosen the lock ring fully and turn the mechanical stop-adjusting knob clockwise until the carriage reaches the desired position. If the horn reaches the desired position before contacting the stop, turn the adjusting knob counter-clockwise until the stop contacts the carriage.
3	Check the height of the horn and make any necessary adjustments to the stop.
4	When you have reached the setting you want, tighten the lock ring. The lock ring will prevent the mechanical stop adjustment from vibrating loose during operation.
5	Place a part in the fixture, reset the air pressure, and perform a test weld.
6	Check that full force develops between the horn and the part. If not, readjust the mechanical stop.

NOTICE	
	<p>Due to Dynamic Follow Through, do not weld in the last 1/4" of stroke.</p>

For 2000Xc Micro actuator

The Mechanical Stop affects the amount of downward travel the Actuator is allowed to have, up to the full stroke length of the unit. The multi-turn knurled knob behind the Stack, on the bottom of the Actuator, is the Mechanical Stop adjustment. The Mechanical Stop knob is graduated to represent the stroke adjustment per turn. The adjustment is 0.025 inch (0.635 mm) per turn.

The Mechanical Stop is designed to stop the horn from contacting your Fixture in the event your part is missing. It is not a precision measuring device, and it is usually *not recommended* that this be used as a 'collapse' or other distance weld limiting device. The "missing part" function can also be used to control critical horn to fixture distances.

Initially, set the mechanical stop to allow at least 1/4 inch of horn travel, but any distance up to the full stroke length is suitable.

To adjust the Mechanical Stop

Table 6.2 To adjust Mechanical Stop of 2000Xc Micro Actuator

Step	Action
1	Remove the factory air from the system or activate the manual dump valve (if installed) and manually lower the carriage until the horn is just above the fixture.
2	If the horn does not reach the fixture and has not travelled 1.75 inches (44.4 mm), loosen the set screws and/or locking nut fully and turn the mechanical stop-adjusting knob counter-clockwise until the carriage reaches the desired position. If the horn reaches the desired position before contacting the stop, turn the adjusting knob clockwise until the stop contacts the carriage.
3	Check the height of the horn and make any necessary adjustments to the stop.
4	When you have reached the setting you want, tighten the set screws and/or locking nut. The set screws and/or locking nut will prevent the mechanical stop adjustment from vibrating loose during operation.
5	Place a part in the fixture, reset the air pressure, and perform a test weld.
6	Check that full force develops between the horn and the part. If not, readjust the mechanical stop.

CAUTION	
	If the Mechanical Stop locking nut is not tightened it may prevent the carriage from returning to the home position.

6.2.6 Emergency Stop

The Emergency Stop is a user control that will prevent the actuator and power supply from running, and will also immediately terminate a weld cycle and cause the Horn to retract. It does not remove power from the system. The front panel display of the power supply will indicate that the system is in emergency stop mode when it is. Twist the emergency stop button to reset the system.

6.3 Operating the Actuator

For detailed information about 2000Xc Series Actuator Controls, refer to [2.5 Actuator Controls and Indicators](#).

To operate the 2000Xc Series Actuator:

Table 6.3 Operating the Actuator

Step	Action
1	If your application has been analyzed in the Branson Applications Laboratory, consult the Branson Lab Report for appropriate settings.
2	Properly adjust the mechanical stop so that the horn does not make contact with your fixture. (Refer to 6.2.5 Mechanical Stop for more information on this adjustment).
3	Ensure that the Emergency Stop button is not pushed in.
4	With a part in place, depress and hold both start switches simultaneously.
5	The horn advances and contacts the part.
6	Force develops between the horn and the part, activating the S-Beam Load Cell.
7	Ultrasonic vibrations are activated. The power bar graph on the power supply indicates loading (usually in the 25% to 100% range). The start switches can now be released.
8	Ultrasonics stop and the horn continues to clamp the part for the hold time you selected.
9	After the completion of the hold cycle, the horn retracts automatically and you can remove the part from the fixture.
10	Weld a few parts using the initial parameters and check for the desired properties.

If you do not obtain optimal results initially, based on the quality of the weld obtained and the loading meter reading, you can alter settings to achieve satisfactory results. Change one setting at a time until a weld is produced in minimum time with maximum strength.

CAUTION	
	This equipment is designed to be operated by one (1) person only.

6.4 Safety Circuit Alarms

The Safety Control System within the actuator constantly monitors the system's safety related components for correct operation. When this system detects a fault condition, operation is interrupted and the system immediately goes to a safe state. A blinking of the power indicator light is used to signal a safety system alarm.

Use the following procedure to troubleshoot safety circuit alarms:

1. Verify that the 9-pin base cable is properly connected to the start connector located on the back of the actuator.
2. Power down and then power up the power supply to reset the system.
3. If the alarm persists, call Branson Support. See [1.4 How to Contact Branson](#).

Chapter 7: Maintenance

7.1	Calibration	108
7.2	Periodic and Preventive Maintenance	109
7.3	Parts Lists	114

7.1 Calibration

This product does not require scheduled Full System Calibration. However, if you are operating under requirements that mandate periodic calibration, for example, the FDA's Good Manufacturing Practices, you may need to calibrate the equipment according to that schedule and set of standards. Contact your Branson representative for additional information.

7.2 Periodic and Preventive Maintenance

WARNING	
	Use LOTO (Lock Out Tag Out) lockable plug cover over line cord plug during any maintenance.

WARNING	
	When performing maintenance on the welder, make sure that no other automated systems are active.

NOTICE	
	A log for recording the maintenance history of the machine should be kept during the machine's life cycle.

The following preventive measures will help ensure long term operation of your Branson 2000Xc Series equipment.

7.2.1 Periodically Clean the Equipment

NOTICE	
	When it is necessary to clean the touch screen, wipe gently with a soft cloth dampened with a mild detergent or Windex. Give a final wipe to the entire screen with the soft damp cloth. Under no circumstances should you use solvents or ammonia to clean the screen. Do not use excessive solution to avoid dripping or seeping into the power supply.

Periodically disconnect the unit from power, remove the cover and vacuum out any accumulated dust and debris. Remove material adhering to the fan blades and motor, transistors, heat sinks, transformers, circuit boards, cooling intake vents, and exhaust ports. Filters can be added to the power supply cooling fans for dusty environments. Periodically disconnect the airline from the air supply, open the air filter and clean the

element and bowl with mild soap and water. External covers may be cleaned with a damp sponge or cloth using a solution of mild soap and water. Do not allow cleaning solution to enter the unit. Exposed steel surfaces, such as handles, hardware and the main column may require a very light film of oil, such as WD-40, to prevent rust in areas of high humidity.

7.2.2 Recondition the Stack (Converter, Booster, and Horn)

Stack components function with greatest efficiency when the mating interface surfaces are in proper condition. For 20 kHz and 30 kHz products, a Branson Mylar washer should be installed between the horn and the booster, and booster and converter. Replace the washer if torn or perforated. We recommend that stacks using Mylar washers be inspected every three months.

Stacks used with silicone grease, as with certain 20 kHz installations and with all 40 kHz products, should be periodically reconditioned to eliminate fretting corrosion. We recommend that a stack using silicone grease be inspected every two weeks for corrosion. The inspection interval can then be adjusted longer or shorter as required, when experience is gained for specific stacks. Refer to the following procedure for correct stack interface reconditioning.

NOTICE	
	<p>The operating efficiency of the equipment will be greatly affected if the mating interfaces of the converter, booster, and horn are not flat, make poor contact with each other, or become corroded. A poor contact condition wastes power and makes tuning difficult. It may also affect the noise level and damage the converter.</p>

To recondition the interfaces:

1. Remove the stack from the actuator
2. Disassemble the converter, booster, and horn stack. Observe the following rules:

In the event that you must disassemble a Stack, always use the correct spanner wrench and a suitable soft-faced vise to remove a horn or booster, and reverse the procedures described earlier in this section.

CAUTION	
	<p>NEVER attempt to remove a horn or booster by holding the converter housing or booster clamp ring in a vise.</p>

NOTICE	
	<p>Use a soft-jawed vise (brass or aluminum) to remove square or rectangular horns, or horns otherwise unremovable, by reversing the procedure detailed in 5.8 Assemble the Acoustic Stack.</p>

3. Wipe the interfaces with a clean cloth or paper towel
4. Examine all interfaces. If any interface is corroded or shows a dark, hard deposit, it should be reconditioned
5. If the interfaces appear to be in good condition, go to step 13
6. If necessary, remove the coupling studs
7. Tape a clean sheet of #400 grit (or finer) emery cloth to a clean, smooth flat surface. A piece of glass is suitable
8. Hold the part to be conditioned at its lower end and carefully stroke it in one direction across the emery cloth. Do not press down. the weight of the component provides enough pressure
9. Perform a second stroke. Rotate the part 1/3 around and stroke it twice across the cloth

NOTICE	
	<p>Use no more than two strokes in one position. Use the same number of strokes at each location.</p>

10. Turn the part the remaining 1/3 and repeat
11. Re-examine the interface and repeat steps 8, 9, and 10 until the surface appears clean and smooth. This should not take more than 2 or 3 complete rotations of the part being reconditioned
12. Clean the threaded hole, using a clean cloth or paper towel
13. Replace the stud with a new one if removed. Torque the 3/8-24 studs to 290 inch pounds (32.77 Nm). Torque 1/2-20 studs to 450 inch pounds (50.84 Nm). Torque M8x1-1/4 studs to 70 inch pounds (7.9 Nm)

NOTICE	
	<p>The use of a Branson torque wrench or the equivalent is recommended. P/N 101-063-787 for 20 kHz systems and 101-063-618 for 40 kHz systems.</p>

CAUTION	
	<p>Failure to follow torque specifications may cause the stud to loosen or break, and the system to overload. The use of a Branson torque wrench or equivalent is required.</p>

14. Reassemble the stack and install it in the actuator, using the procedures in [5.8 Assemble the Acoustic Stack](#)

7.2.3 Routine Component Replacement

The lifetime of certain parts is based on the number of cycles the unit has completed, or on hours of operation (e.g., at 20,000 hours, cooling fans should be replaced). [Table 7.1](#) lists the average number of hours or cycles one should use in determining when actuator components should be replaced. Ambient operating temperature also affects lifetime. Higher temperatures reduce the number of cycles and hours before replacement is suggested. The charts below are for equipment operating at a temperature of 72 to 75° F (22 - 24° C).

The lifetime of system pneumatic components is influenced by the quality of the compressed air provided. All Branson systems require clean, dry, (normal) factory compressed air. When oil or moisture is present in the compressed air, the lifetime of the pneumatic components will be reduced. This table lists pneumatic parts with an average factory compressed air condition.

Table 7.1 Routine Component Replacement

Cycles	Component	EDP number (only for 2000Xc Micro Actuator)
At 10 Million Cycles	Air Cylinder	560-198-070 (Dia.32mm) 560-198-071 (Dia.40mm)
	Hydraulic snubber	890-198-059R
At 20 Million Cycles	Base Palm Buttons	890-161-044R
	Solenoid Valves	560-087-123
At 40 Million Cycles	Pressure Regulator	560-087-120
	Air Filter	890-117-050R
	Cooling Valve	560-087-041
	Rapid Traverse Valve	560-087-124
	S-Beam Load Cell Assembly	560-040-010
	Encoder Assembly	560-087-150
	Linear Bearing (2" stroke or greater)	890-053-153

For Reference Purposes:

1. A system operating at 60 welds per minute, 8 hours per day, 5 days per week, 50 weeks per year completes approximately 7.2 million cycles in 2000 hours.

2. The same system at 24 hours per day, 5 days per week, in 50 weeks completes 21.6 million cycles in 6000 hours.
3. 24 hours per day, 365 days per year produces 31.5 million cycles in 8760 hours.

Please note that parts replaced during preventive maintenance constitute normal wear and tear. They are not covered by warranty.

7.3 Parts Lists

7.3.1 Actuator Parts Lists

The following tables list the available Accessories and Parts for the 2000Xc Series Actuator:

Table 7.2 Accessories List for 2000Xc Series Actuator

Description	EDP Number
2000Xc Micro with 32mm diameter cylinder (Only for 2000Xc Micro actuator)	510-294-260
2000Xc Micro with 40mm diameter cylinder (Only for 2000Xc Micro actuator)	510-294-261
2000Xc Series Actuator with 1.5-inch diameter cylinder (Only for 2000Xc AEC actuator)	101-134-414
2000Xc Series Actuator with 2.0-inch diameter cylinder (Only for 2000Xc AEC actuator)	101-134-415
2000Xc Series Actuator with 2.5-inch diameter cylinder (Only for 2000Xc AEC actuator)	101-134-416
2000Xc Series Actuator with 3.0-inch diameter cylinder (Only for 2000Xc AEC actuator)	101-134-417
Air Cylinder 1.5"	100-246-1729
Air Cylinder 2.0"	100-246-858
Air Cylinder 2.5"	100-246-576
Air Cylinder 3.0"	100-246-573
Air Cylinder 3.25"	149-088-859
Electronic Down Speed Control Assembly 3.25", 3.0", 2.5"	100-246-1680R
Electronic Down Speed Control Assembly 2.0", 1.5"	100-246-1682R
Rapid Traverse Valve	100-246-1660R
Primary Solenoid Valve	100-246-1679R
Palm Button	200-099-236R
EN E-stop Button	200-099-309
Gauge Assembly	100-246-903
Electronic Regulator Assembly	100-246-1659R
Air Filter (5 micron)	200-163-032
Rapid Traverse Valve	100-246-1660R
Actuator Interface Board (Only for 2000Xc Micro actuator)	102-242-1313R
Flow Control Assembly (Only for 2000Xc Micro actuator)	560-087-121

Table 7.2 Accessories List for 2000Xc Series Actuator

Description	EDP Number
Assy Valve Process Assembly (Only for 2000Xc Micro actuator)	560-087-122
E-stop Switch (Only for 2000Xc Micro actuator)	890-161-945
8.5' Start Cable	101-240-020R
Kit Base Guard (for large horns)	101-063-550
Inch Leveling Plate	101-063-358
Metric Ball Bolt (adapts 2000Xc Series base to leveling plates)	100-298-085
Metric Leveling Plate	1015704
CJ20 Acorn (in actuator)	101-135-059R
CA30 Acorn	101-135-114R
30 kHz Booster Adapter Ring (for use with CA30)	100-087-283
4TJ Acorn (in actuator)	101-135-041R
40 kHz Adapter Sleeve Assy	100-246-612
Stand-Base 4" OD, 3.5" ID, col, support	100-246-1314
Stand-Hub, 4" OD, col, support	100-246-1586
Base, ergo - 4" metric, black	100-246-1578
Hub, 2000Xc Series for 4" column	101-063-583
Support 4" black	100-246-1311
COLUMN 40" 4.0"ODX3.5"ID (Only for 2000Xc AEC actuator)	100-028-021
COLUMN 4'(4.0"ODX3.0"ID) (option) (Only for 2000Xc AEC actuator)	100-028-011
COLUMN 4.0"ODX3.0"IDx6' (option) (Only for 2000Xc AEC actuator)	100-028-012
Column 750mm, 65 OD (Only for 2000Xc Micro actuator)	580-287-100
Base Structure, 2000Xc Micro	510-294-011
Base (Machining), 2000Xc Micro	580-056-218
Main Support (Machining), 2000Xc Micro	580-164-180
Leveling Plate Kit	560-005-045
Support Washer (only for 2000Xc Micro Solid Mount Booster)	109-114-243
Sleeve, 1/4" wall column	100-094-159

Table 7.2 Accessories List for 2000Xc Series Actuator

Description	EDP Number
Sleeve, 1/2" wall column	100-094-102
20 kHz Series Boosters 1/2-20 Input; 1/2-20 Output	
Black (Ti), Ratio 1:2.5	101-149-059
Silver (Ti), Ratio 1:2	101-149-058
Gold (Ti), Ratio 1:1.5	101-149-057
Green (Ti), Ratio 1:1	101-149-056
Purple (Ti), Ratio 1:0.6	101-149-060
Silver (Al), Ratio 1:2	101-149-053
Gold (Al), Ratio 1:1.5	101-149-052
Green (Al), Ratio 1:1	101-149-051
Purple (Al), Ratio 1:0.6	101-149-055
Solid Mount Boosters - 20 kHz - 1/2-20 Input, 1/2-20 Output	
Black (Ti), Ratio 1:2.5	101-149-099
Silver (Ti), Ratio 1:2	101-149-098
Gold (Ti), Ratio 1:1.5	101-149-097
Green (Ti), Ratio 1:1	101-149-096
Purple (Ti), Ratio 1:0.6	101-149-095
Boosters - 30 kHz, for use with CA-30 converter	
Black (Ti), Ratio 1:2.5	101-149-120
Silver (Ti), Ratio 1:2.0	101-149-121
Gold (Ti), Ratio 1:1.5	101-149-122
Green (Ti), Ratio 1:1	101-149-123
Purple (Ti), Ratio 1:0.6	101-149-124
Boosters - 40 kHz (Same as XL: 8 mm)	
Black (Ti), Ratio 1:2.5	101-149-084
Silver (Ti), Ratio 1:2.0	101-149-083
Gold (Ti), Ratio 1:1.5	101-149-086
Green (Ti), Ratio 1:1	101-149-085
Black (Al), Ratio 1:2.5	101-149-082
Silver (Al), Ratio 1:2.0	101-149-081R
Gold (Al), Ratio 1:1.5	101-149-080
Green (Al), Ratio 1:1	101-149-079

Table 7.2 Accessories List for 2000Xc Series Actuator

Description	EDP Number
Purple (Al), Ratio 1:0.6	101-149-087
Solid Mount Boosters - 40 kHz (Same as XL: 8mm)	
Black (Ti), Ratio 1:2.5	109-041-174
Silver (Ti), Ratio 1:2.0	109-041-175
Gold (Ti), Ratio 1:1.5	109-041-176
Green (Ti), Ratio 1:1.0	109-041-177
Purple (Ti), Ratio 1:0.6	109-041-178

NOTICE	
	<p>When ordering spare cylinders note the cylinder diameter which is found on the actuator door cover and/or on a label on the rear of the actuator.</p>

Appendix A: Manual Revisions

A.1 Manual Revisions120

A.1 Manual Revisions

Refer to the table below for the appropriate manual revision depending on your Actuator's manufacturing date.

Table A.1 Manual revisions

Manual Revision	Power Supply Manufacturing Date	
	From	To
1	May 2015	July 2015
2	August 2015	December 2015
3	January 2016	July 2016
4	August 2016	November 2017
5	December 2017	August 2018
6	September 2018	June 2019
7	July 2019	March 2020
8	April 2020	November 2020
9	December 2020	September 2022
10	October 2022	May 2023
11	June 2023	June 2025
12	July 2025	To date

Figure A.1 Location of the information Label in the 2000Xc Actuator



MODEL: ACTUATOR 2.0AEC 2000X EN
EDP: 101-134-415
S/N: ###YYMM####



Made In Mexico

BRANSON

S/N: ###YYMM####



1. Prefix
2. Year of Manufacture
3. Month of Manufacture
4. Incremental Serial Number

Index

Numerics

21 CFR Part 11 Capability 34

A

AB Amplitude 25
AB Delay 25
AB Time 25
Absolute Cutoff 25
Absolute Distance 25
Absolute Mode 25
Absolute Position 25
Accept-as-is 25
Acoustic Stack 84
Act Clr Output 25
Actual 25
Actuator 17, 25
Actuator Alignment 100
Actuator Controls 24, 98
Actuator Operation 97
Actuator Settings 99
Adjust While Running 20
Afterburst 20, 25
Air Cylinder Consumption 65
Air Filter 64
Air Pressure Indicator 99
Alarm Beeper 25
Alarm Log 25
Amp A 25
Amp B 25
Amp Control 25
Amplitude 25
Amplitude Graph 25
Amplitude Step 26
Amplitude Stepping 20
Authority Check 26
Auto Scale Graph 26
Auto Seek 16
Automatic 26
Automatic Preset Naming 20
Automation 26
AutoTune with Memory (AT/M) 16
Autotuning 20

B

Basic/Expert 26
Batch Setup 26
Beep 26
Booster 18, 26

Branson
how to contact 8

C

Cables 55
Cal Actuator 26
Cal Sensor 26
Calibration 108
Carriage and Slide System 17
Carriage Door 24
Clamping Force 26
Cold Start 26
Collapse Distance 26
Collapse Limits 20
Collapse Mode 26
Compatibility 19
Components Verify 26
Control Limits 20, 26
Converter 18, 26
Counters 27
Cycle Aborts 20, 27
Cycle Time 20

D

Date Stamp 20
Delivery and Handling 35
Digital Amplitude 20
Digital Filter 27
Digital Frequency 27
Digital Horn Test 20
Digital Tuning 20
Digital UPS 20
DIP Switch 80
Downspeed 20, 27
Downspeed Control 24, 100
Downspeed Tuning 27
Dynamic Follow Through 21

E

Electrical Input Power Ratings 63
Emergency Stop 81, 102
Emissions 6
Encoder 17, 20
Energy Braking 27
Energy Compensation 20, 27
Energy Mode 27
English (USCS)/Metric Units 20
Environmental Specifications 36, 63
Event History 27
Executive 27
External Amplitude Control 27
External Frequency Control 27
External U/S Delay 27
Extra Cooling 27

F

- F Actual 27
- F Memory 28
- Factory Air 63
- Factory Air Source 100
- FDA 34, 108
- Features 20
- Force 28
- Force Act 28
- Force Graph 28
- Force/Col Graph 28
- Foreign Languages 20
- Freq Chg 28
- Freq End 28
- Freq Max 28
- Freq Min 28
- Freq Start 28
- Frequency 28
- Frequency Graph 28
- Frequency Offset 16, 20, 28
- Front Panel Controls 23

G

- General Alarm 28
- General Precautions 5
- Glossary 25
- Gnd Det. Mode 28
- Graphs 21
- Ground Det. Cutoff 28
- Guards 81

H

- Handling and Unpacking 51
- Help 95
- Hold Force 28
- Hold Pressure 28
- Hold Time 28
- Horn 18
- Horn Clamp 28
- Horn Down 21, 29
- Horn Down Display 21
- Horn Down Mode 21
- Horn Scan 21
- Horn Travel 100
- how to contact Branson 8

I

- I/O Connector 29
- Indicator Light 24
- Input Power 71
- Input Power Plug 79
- Installation and Setup 49
- Installation Requirements 56
- Installation Steps 66
- Intended Use of the System 6
- Interconnect 72

Introduction 13
Inventory 54

K

Key 29

L

Limits, Control 21
Limits, Reject 21
Limits, Suspect 21
Line Regulation 16
Linear Encoder 29
Load Regulation 16
Location 56

M

Main Menu 29
Maintenance 107
Max Energy 29
Mechanical Stop 24, 101
Membrane Keyboard 21
Memory Full 29
Min Energy 29
Minus Limit 29
Missing Part 29
Models Covered 14
Mounting the Stand 66

O

Operator 29
Operator Authority 29
Output Power 71

P

P/Col Graph 29
P/Force Graph 29
Parameter Entry 21
Parameter Range 21, 29
Part ID Scan 29
Parts Lists 114
Password Protection 21
Password Recovery Kit 29
Peak Power 30
Peak Power Cutoff 30
Plus Limit 30
Pneumatic Air Prep 30
Pneumatic Connections 64
Pneumatic System 18
Pneumatic Tubing 64
Post Weld Seek 21, 30
Power Bar Graph 23
Power Button 23
Power Graph 30
Preset 30
Preset Barcode Start 30

- Preset Name 30
- Presets 21
- Presets, External Selection 30
- Pressure Limits 30
- Pressure Regulator 24
- Pressure Sensor 21
- Pressure Step 30
- Pretrg @ D 30
- Pretrig Amp 30
- Pretrigger 21, 30
- Preventive Maintenance 109
- Principle of Operation 15
- Process Alarm 21

R

- Rack Mount 82
- Rack Mount Enclosure 20
- Ramp Time 21
- Rapid Traverse 21
- Rapid Traverse/RAPID TRAV 30
- Ready Position 30
- Recall Preset 30
- Receiving 37
- Recondition the Stack 110
- Regulated Air Pressure 99
- Regulatory Compliance 6
- Reject Limits 31
- Reset Button 23
- Reset Required 31
- Returning Equipment 39
- Run Screen 31

S

- Safety and Support 1
- Safety Circuit Alarms 105
- Safety Control 21
- Safety Requirements and Warnings 2
- Sampling Rate 20
- S-Beam Load Cell 16, 17, 21, 31
- Scrub Time 31
- Seek 21, 31
- Setting up the Workplace 6
- Setup Checking 22
- Setup Limits 31
- Shipping and Handling 36
- Stack 31
- Stand 52
- Start Frequency 31
- Start Switch Connection 74
- Step @ Col (in) 31
- Step @ E (J) 31
- Step @ Ext Sig 31
- Step @ Pwr (%) 31
- Step @ T (S) 31
- Supervisor 31
- Suspect Limits 31

- SV Interlock 31
- Symbols Found in this Manual 2
- Symbols Found on the Product 3
- Sys Components 31
- System Information 22
- System Protection 16

T

- Technician 31
- Test Button 23
- Test Diagnostics 22
- Test Scale 32
- Testing 94
- Time Mode 32
- Timed Seek 22
- Timeout 32
- Trig Delay 32
- Trigger 32
- Trigger Beeper 32
- True Wattmeter 22

U

- Ultrasonic Stack 18
- Unpacking 38
- Upper Limit Switch (ULS) 32
- UPS 32
- USB Copy Now 32
- USB Streaming Data Setup 32
- User I/O 32
- User I/O Interface 76
- User ID Setup 32
- User-defined Limits 32

V

- Velocity Graph 32
- View Setup 33

W

- Weld Count 33
- Weld Energy 33
- Weld Force 33
- Weld History 33
- Weld History Setup 33
- Weld Modes 22
- Weld Results 33
- Weld Scale 33
- Weld Time 33
- Windows Setup 33
- Write In Fields 33

X

- X Scale Graph 33