



2000X Distance Power Supply

Operating Manual

Branson Ultrasonics Corp.
120 Park Ridge Road
Brookfield, CT 06804
(203) 796-0400
<http://www.bransonultrasonics.com>

Branson Ultrasonics (Shanghai) Co., Ltd.
2nd Floor, Building No. 5
No 758, East Rong Le Road,
Song Jiang Industrial Zone, Shanghai, PRC, 201613
86-21-3781-9600
<http://www.bransonultrasonics.com>

BRANSON

Manual Change Information

At Branson, we strive to maintain our position as the leader in ultrasonics plastics joining, cleaning and related technologies by continually improving our circuits and components in our equipment. These improvements are incorporated as soon as they are developed and thoroughly tested.

Information concerning any improvements will be added to the appropriate technical documentation at its next revision and printing. Therefore, when requesting service assistance for specific units, note the Revision information found on this document, and refer to the printing date which appears on this page.

Copyright

Copyright © 2025 Branson Ultrasonics Corporation. All rights reserved. Contents of this publication may not be reproduced in any form without the written permission of Branson Ultrasonics Corporation.

Loctite is a registered trademark of Henkel Corporation U.S.A.

Other trademarks and service marks mentioned herein are held by their respective owners.

Foreword

Congratulations on your choice of a Branson Ultrasonics Corporation system!

The Branson 2000X Series system is process equipment for the joining of plastic parts using ultrasonic energy. It is the newest generation of product using this sophisticated technology for a variety of customer applications. This Instruction Manual is part of the documentation set for this system, and should be kept with the equipment.

Thank you for choosing Branson!

Introduction

This manual is arranged into several structured chapters which will help you find the information you may need to know to safely handle, install, set up, program, operate, and/or maintain this product. Please refer to the [Table of Contents](#) and/or the Index of this manual to find the information you may be looking for. In the event you require additional assistance or information, please contact our Product Support department (see [1.4 How to Contact Branson](#) for information on how to contact them) or your local Branson representative.

Table of Contents

Chapter 1: Safety and Support

| | | |
|-----|---|----|
| 1.1 | Safety Requirements and Warnings | 2 |
| 1.2 | General Precautions | 3 |
| 1.3 | Warranty | 6 |
| 1.4 | How to Contact Branson | 7 |
| 1.5 | Returning Equipment for Repair | 8 |
| 1.6 | Obtaining Replacement Parts | 11 |
| 1.7 | Disposing Obsolete Machines and Accessories | 12 |

Chapter 2: The 2000X Distance Power Supply

| | | |
|-----|---|----|
| 2.1 | Models Covered | 14 |
| 2.2 | Overview of these Models | 15 |
| 2.3 | Compatibility with Branson Products | 16 |
| 2.4 | Features | 17 |
| 2.5 | Front Panel Controls | 21 |
| 2.6 | Welding Systems | 22 |
| 2.7 | Glossary | 23 |

Chapter 3: Delivery and Handling

| | | |
|-----|---------------------------------|----|
| 3.1 | Shipping and Handling | 30 |
| 3.2 | Receiving | 31 |
| 3.3 | Unpacking | 32 |
| 3.4 | Returning Equipment | 33 |

Chapter 4: Installation and Setup

| | | |
|------|---|----|
| 4.1 | About Installation | 36 |
| 4.2 | Handling and Unpacking | 37 |
| 4.3 | Take Inventory of Small Parts | 42 |
| 4.4 | Installation Requirements | 44 |
| 4.5 | Installation Steps | 49 |
| 4.6 | Start Switch Connection (Automation) | 57 |
| 4.7 | Guards and Safety Equipment | 64 |
| 4.8 | Rack Mount Installation | 65 |
| 4.9 | Assemble the Acoustic Stack | 67 |
| 4.10 | Installing the Ultrasonic Stack in the Actuator | 72 |
| 4.11 | Testing the Installation | 75 |
| 4.12 | Still Need Help? or Parts? Have Questions? | 76 |

Chapter 5: Technical Specifications

| | | |
|-----|---|----|
| 5.1 | Technical Specifications | 78 |
| 5.2 | Physical Description | 80 |
| 5.3 | Standard Modules and Components | 81 |

Chapter 6: Operation

| | | |
|-----|--|-----|
| 6.1 | Operating System | 90 |
| 6.2 | 2000X External Communication Functions | 92 |
| 6.3 | 2000X Distance Power Supply External Communication Functions | 93 |
| 6.4 | Front Panel Controls | 101 |
| 6.5 | System Menus | 109 |

| | | |
|-------------------------------------|---|-----|
| 6.6 | Using the Main Menu | 112 |
| 6.7 | Using the Weld Setup Menu | 140 |
| Chapter 7: Maintenance | | |
| 7.1 | 2000X Series Preventive Maintenance | 166 |
| 7.2 | Calibration | 167 |
| 7.3 | Parts Lists. | 168 |
| 7.4 | Troubleshooting. | 173 |
| 7.5 | System Alarm Tables | 175 |
| 7.6 | Service Events. | 221 |
| 7.7 | Parts Replacement. | 223 |
| Appendix A: Automation | | |
| A.1 | FAQ: 2000 Series Automation | 238 |
| Appendix B: Alarm Index | | |
| Appendix C: Manual Revisions | | |
| C.1 | Manual Revisions | 250 |

List of Figures

Chapter 1: Safety and Support

Chapter 2: The 2000X Distance Power Supply

| | | |
|------------|--|----|
| Figure 2.1 | 2000X distance Power Supply Front Panel Display after Power-Up | 21 |
|------------|--|----|

Chapter 3: Delivery and Handling

Chapter 4: Installation and Setup

| | | |
|-------------|--|----|
| Figure 4.1 | Linear Encoder is sensitive; Do Not Handle it! | 37 |
| Figure 4.2 | Unpacking the Stand (Actuator on a Base); right-side view of Stand | 38 |
| Figure 4.3 | Unpacking the Stand (Actuator on a Hub); Hub shown separately | 39 |
| Figure 4.4 | Ultrasonic Converter (J-Type for stand use) and Booster. | 41 |
| Figure 4.5 | Lead Actuator Dimensional Drawing. | 45 |
| Figure 4.6 | Power Supply Dimensional Drawing | 46 |
| Figure 4.7 | Base Mounting Centers | 50 |
| Figure 4.8 | Mounting Bolt Pattern for the Hub (for Stand on Hub) | 51 |
| Figure 4.9 | Actuator Rear View, Mounting Surface, Bolt and Guide Pin Locations | 53 |
| Figure 4.10 | Connections on Rear of Power Supply. | 54 |
| Figure 4.11 | Electrical Connections from Power Supply to a 2000X-series Actuator. | 56 |
| Figure 4.12 | Start Switch Connection Codes (Non-CE Actuator) | 57 |
| Figure 4.13 | Start Switch Connection Codes (CE Actuator) | 57 |
| Figure 4.14 | User I/O Cable Identification and Wire Color Diagram. | 59 |
| Figure 4.15 | International Harmonized Line Cord Color Code | 62 |
| Figure 4.16 | Actuator Emergency Stop Button | 64 |
| Figure 4.17 | Detail of Rack Mount Handle Kit Assembly. | 65 |
| Figure 4.18 | Assembling the 20 kHz Acoustic Stack | 70 |
| Figure 4.19 | Connecting Tip to Horn | 71 |
| Figure 4.20 | Installing a 20 kHz Stack in a Branson Actuator. | 72 |
| Figure 4.21 | Installing the 40 kHz Stack in a Branson Actuator | 73 |
| Figure 4.22 | Mounting Circles on Base | 74 |
| Figure 4.23 | Normal Front Panel Display after Power-Up | 75 |

Chapter 5: Technical Specifications

| | | |
|-------------|---|----|
| Figure 5.1 | Rear View of 2000X Power Supply | 80 |
| Figure 5.2 | 20 kHz CR20 Converter Dimensions | 82 |
| Figure 5.3 | 20 kHz Booster Dimensions | 83 |
| Figure 5.4 | 20 kHz Converter/Booster/Horn, Typical Dimensions | 83 |
| Figure 5.5 | 30 kHz Converter Dimensions | 84 |
| Figure 5.6 | 30 kHz Booster Dimensions | 84 |
| Figure 5.7 | 30 kHz, CA - 30 Converter with Booster | 85 |
| Figure 5.8 | 30 kHz Converter/Booster/Horn, Typical Dimensions | 85 |
| Figure 5.9 | 40 kHz, 4TR and 4TJ Converter Dimensions | 86 |
| Figure 5.10 | 40 kHz, 4TH Converter Dimensions | 86 |
| Figure 5.11 | 40 kHz, 4TP Converter Dimensions. | 87 |
| Figure 5.12 | 40 kHz Booster Dimensions | 87 |
| Figure 5.13 | 40 kHz Converter/Booster/Horn, Typical Dimensions | 88 |

Chapter 6: Operation

| | | |
|-------------|---|-----|
| Figure 6.1 | UWF Configuration Utility | 90 |
| Figure 6.2 | System Configuration Menu | 93 |
| Figure 6.3 | Local Security Setting | 96 |
| Figure 6.4 | Windows Setup | 96 |
| Figure 6.5 | Server Box | 97 |
| Figure 6.6 | Remote Desktop Connection | 97 |
| Figure 6.7 | Enable "Do not require CTRL + ALT + DEL" | 98 |
| Figure 6.8 | 2000X Distance File on the desktop | 98 |
| Figure 6.9 | Remote Desktop Connection | 98 |
| Figure 6.10 | Front Panel of the 2000X Power Supply | 102 |
| Figure 6.11 | Typical Weld Results as displayed on the Opening Screen | 109 |
| Figure 6.12 | Column Setup Screens | 110 |
| Figure 6.13 | Test Screen | 111 |
| Figure 6.14 | System Information Screen | 125 |
| Figure 6.15 | Diagnostics Screen | 126 |
| Figure 6.16 | Horn Signature screen during scan | 128 |
| Figure 6.17 | Horn Signature Screen | 128 |
| Figure 6.18 | Compare Data Screen | 129 |
| Figure 6.19 | Horn Down Screen | 130 |
| Figure 6.20 | Save/Recall Presets Screen | 131 |
| Figure 6.21 | Save Presets Pop-up Screen | 132 |
| Figure 6.22 | Name Preset Keypad | 133 |
| Figure 6.23 | Verify Preset Screen | 134 |
| Figure 6.24 | Calibration Screens | 137 |
| Figure 6.25 | Weld Setup Screen Number 1 | 140 |
| Figure 6.26 | Weld Setup Screen Number 2 | 140 |
| Figure 6.27 | Weld Setup Screen Number 3* | 141 |
| Figure 6.28 | Weld Mode Select Screen* | 142 |
| Figure 6.29 | Time Weld Mode Setup | 143 |
| Figure 6.30 | Energy Weld Mode Setup | 144 |
| Figure 6.31 | Peak Power Weld Mode Setup | 145 |
| Figure 6.32 | Collapse Distance Weld Mode Setup | 146 |
| Figure 6.33 | Absolute Distance Weld Mode Setup | 147 |
| Figure 6.34 | Ground Detect Weld Mode Setup | 148 |
| Figure 6.35 | Graph Screen | 163 |
| Figure 6.36 | View Graphs Screen | 163 |

Chapter 7: Maintenance

| | | |
|------------|---|-----|
| Figure 7.1 | Interconnect Diagram, Power Supply | 172 |
| Figure 7.2 | Alarm Signal Displayed on the System Information Screen | 173 |
| Figure 7.3 | Component Location of 2000X Modules | 224 |
| Figure 7.4 | Front Panel, Exploded Parts View | 224 |
| Figure 7.5 | Location and Orientation of U53, U54, U55, and U56 | 230 |
| Figure 7.6 | SBC PC Board Connector Layout | 231 |
| Figure 7.7 | Lineboard EDP 100-242-1199R* | 233 |

Appendix A: Automation

Appendix B: Alarm Index

Appendix C: Manual Revisions

| | | |
|------------|--|-----|
| Figure C.1 | Location of the information Label in the 2000X Distance Power Supply | 251 |
|------------|--|-----|

List of Tables

Chapter 1: Safety and Support

| | | |
|-----------|----------------------------|---|
| Table 1.1 | Branson Contacts | 9 |
|-----------|----------------------------|---|

Chapter 2: The 2000X Distance Power Supply

| | | |
|-----------|--|----|
| Table 2.1 | Power Supply Compatibility with Branson Converters | 16 |
|-----------|--|----|

Chapter 3: Delivery and Handling

| | | |
|-----------|---|----|
| Table 3.1 | Environmental Specifications | 30 |
| Table 3.2 | To inspect the Power Supply when it is delivered, take the following steps. | 31 |
| Table 3.3 | Unpacking Procedure. | 32 |

Chapter 4: Installation and Setup

| | | |
|------------|--|----|
| Table 4.1 | Small Parts Included (=x) with Power Supply and/or Actuator Assemblies | 42 |
| Table 4.2 | List of Cables | 42 |
| Table 4.3 | Environmental Specifications | 47 |
| Table 4.4 | Input Power Requirements | 47 |
| Table 4.5 | User I/O Cable Pin Assignments, Alphabetical Order | 59 |
| Table 4.6 | User I/O Input and Output Function Selection. | 62 |
| Table 4.7 | User I/O DIP Switch Functions | 63 |
| Table 4.8 | Rack Mount Handle Kit Assembly | 65 |
| Table 4.9 | Tools | 67 |
| Table 4.10 | Assembly for a 15 kHz and 20 kHz System. | 67 |
| Table 4.11 | Assembly for a 30 kHz System | 68 |
| Table 4.12 | Assembly for a 40 kHz System | 69 |
| Table 4.13 | Stud Torque Values. | 70 |
| Table 4.14 | Tip to Horn Torque Values | 71 |

Chapter 5: Technical Specifications

| | | |
|-----------|---|----|
| Table 5.1 | Environmental Requirements | 78 |
| Table 5.2 | Electrical Input Operating Voltages | 78 |
| Table 5.3 | Input Current and Fuse Requirements | 78 |

Chapter 6: Operation

| | | |
|------------|---|-----|
| Table 6.1 | Trigger Force Range @ Max System Pressure | 104 |
| Table 6.2 | Trigger Force Range @ Max System Pressure 20MA | 104 |
| Table 6.3 | Trigger Force Range @ Max System Pressure 20DP. | 105 |
| Table 6.4 | Suspect and Reject Parameter Value Range | 105 |
| Table 6.5 | Testing the Welding System | 107 |
| Table 6.6 | Code Output. | 115 |
| Table 6.7 | Failures and associated alarms when start signal is lost. | 118 |
| Table 6.9 | Preset Naming | 132 |
| Table 6.10 | Weld Modes | 141 |

Chapter 7: Maintenance

| | | |
|-----------|---|-----|
| Table 7.1 | Replacement Parts List for 2000X distance Power Supply. | 168 |
| Table 7.2 | 2000X-Series System Cables (External). | 169 |
| Table 7.3 | Suggested Spares. | 170 |
| Table 7.4 | Cycle Modified Alarms and Messages, with Probable Cause and Corrective Action | 175 |
| Table 7.5 | Failure of Alarms and Messages, with Probable Cause and Corrective Action | 177 |

| | | |
|------------|---|-----|
| Table 7.6 | No Cycle Alarms and Messages, with Probable Cause and Corrective Action | 184 |
| Table 7.7 | Suspect/Reject Alarms and Messages, with Probable Cause and Corrective Action . . | 186 |
| Table 7.8 | Setup Alarms and Messages, with Probable Cause and Corrective Action | 195 |
| Table 7.9 | Overload Alarms and Messages, with Probable Cause and Corrective Action | 217 |
| Table 7.10 | Note Alarms and Messages, with Probable Cause and Corrective Action | 219 |
| Table 7.11 | Voltage Test Points | 221 |
| Table 7.12 | Removing the Touch Screen Display (VGA) | 225 |
| Table 7.13 | Removing the Power Supply Module | 226 |
| Table 7.14 | Removing the DC Power Supply | 227 |
| Table 7.15 | Removing the User I/O Board | 228 |
| Table 7.16 | Removing the Battery for the Backup RAM (BBRAM) | 228 |
| Table 7.17 | Removing the System Controller Board | 229 |
| Table 7.18 | Removing the SBC PC Board | 231 |
| Table 7.19 | Reinstalling the SBC Board | 232 |
| Table 7.20 | Removing the Line Board | 233 |
| Table 7.21 | Removing and Replacing the Line Fuses | 235 |
| Table 7.22 | Removing a Cooling Fan | 236 |

Appendix A: Automation

| | | |
|-----------|---------------------------|-----|
| Table A.1 | Air Consumption | 241 |
|-----------|---------------------------|-----|

Appendix B: Alarm Index

Appendix C: Manual Revisions

| | | |
|-----------|----------------------------|-----|
| Table C.1 | Manual revisions | 250 |
|-----------|----------------------------|-----|

Chapter 1: Safety and Support

| | | |
|------------|--|-----------|
| 1.1 | Safety Requirements and Warnings | 2 |
| 1.2 | General Precautions | 3 |
| 1.3 | Warranty | 6 |
| 1.4 | How to Contact Branson | 7 |
| 1.5 | Returning Equipment for Repair | 8 |
| 1.6 | Obtaining Replacement Parts | 11 |
| 1.7 | Disposing Obsolete Machines and Accessories | 12 |

This chapter contains an explanation of the different Safety Notice symbols and icons found both in this manual and on the product itself and provides additional safety information for ultrasonic welding. This chapter also describes how to contact Branson for assistance.

1.1 Safety Requirements and Warnings

1.1.1 Symbols found in this Manual

Three symbols used throughout the manual warrant special attention:

| NOTICE | |
|---|--|
|  | A Note contains important information. It does not alert the user to potential injury, but only to a situation that might eventually require additional work or modification if you ignore it initially. |

| CAUTION | |
|--|--|
|  | A Caution indicates a potentially hazardous situation, which, if not avoided, can result in minor or moderate injury. It can also alert the user to unsafe practices or conditions that can damage equipment if not corrected. |

| WARNING | |
|---|--|
|  | A Warning indicates a hazardous situation or practice that, if not avoided, can result in serious injury or death. |

1.1.2 Symbols found on the Product

The 2000X Distance Power Supply has several warning labels on it to indicate the presence of hazardous voltages inside the unit.

1.2 General Precautions

Take the following precautions before servicing the power supply:

- Be sure the power switch is in the Off position before making any electrical connections.
- To prevent the possibility of an electrical shock, always plug the power supply into a grounded power source.
- Power supplies produce high voltage. Before working on the power supply module, do the following:
 - Turn off the power supply;
 - Unplug main power; and
 - Allow at least 5 minutes for capacitors to discharge.
- High voltage is present in the power supply. Do not operate with the cover removed.
- High line voltages exist in the ultrasonic power supply module. Common points are tied to circuit reference, not chassis ground. Therefore, use only non-grounded, battery-powered multimeters when testing these modules. Using other types of test equipment can present a shock hazard.
- Be sure power is disconnected from the power supply before setting a DIP switch.
- Keep hands from under the horn. Down force (pressure) and ultrasonic vibrations can cause injury.
- Do not cycle the welding system if either the RF cable or converter is disconnected.
- When using larger horns, avoid situations where fingers could be pinched between the horn and the fixture.

| CAUTION | Loud Noise Hazard |
|---|---|
|  | <p>Sound level and frequency of the noise emitted during the ultrasonic assembly process may depend upon a. type of application, b. size, shape and composition of the material being assembled, c. shape and material of the holding fixture, d. welder setup parameters and e. tool design. Some parts vibrate at an audible frequency during the process. Some or all of these factors may result in an uncomfortable noise being emitted during the process. In such cases operators may need to be provided with personal protective equipment. See 29 CFR (Code of Federal Regulations) 1910.95 Occupational Noise Exposure.</p> |

| CAUTION | Corrosive Material Hazard |
|---|---|
|  | <p>First aid measures (in case of electrolyte leakage from the battery)</p> <p>Eye Contact: Flush the eyes with plenty of clean water for at least 15 minutes immediately, without rubbing. Get immediate medical treatment.</p> <p>If appropriate procedures are not taken, this may cause eye injury.</p> <p>Skin Contact: Wash the affected area under tepid running water using a mild soap. If appropriate procedures are not taken, this may cause sores on the skin. Get medical attention if irritation develops or persists.</p> <p>Inhalation: Remove to fresh air immediately. Get medical treatment immediately.</p> |

1.2.1 Intended Use of the System

The 2000Xd Power Supply and Actuator are components of an ultrasonic welding system. These are designed for a wide variety of welding or processing applications.

1.2.2 Emissions

When being processed, certain plastic materials can emit toxic fumes and/or gases hazardous to user health.

Where such materials are processed, proper ventilation of the workstation is required. Check with your materials suppliers for recommended protection when processing their materials.

| WARNING | |
|---|---|
|  | Processing of many materials, such as PVC, can be hazardous to an operator's health and could cause corrosion/damage to the equipment. Use proper ventilation and take protective measures. |

1.2.3 Setting up the Workplace

Measures for setting up a workplace for safe operation of the ultrasonic welder are outlined in Chapter 4: Installation and Setup and in the 2000 Series Installation Guide shipped with the Power Supply.

1.2.4 Regulatory Compliance

This product meets electrical safety requirements and EMC (Electromagnetic Compliance) requirements for North America and the European Union.

1.2.5 Compliance with Safety Standards

COMPLIANCE WITH SAFETY STANDARDS

PRODUCTS: 2000X Series Stand and Power Supply

A standard 2000X Series Actuator or Stand connected to a 2000X t/ea/d Power Supply when used with dual start switches and an emergency stop switch (mounted in the Base) is in compliance with the following OSHA requirements:

29 CF R Chapter XV II - Occupational Safety and Health Administration - Subpart O - Machinery and Machine Guarding - Section 1910.212 General requirements for all machines Subsection (a) Machine guarding.

When it is operated in this configuration it provides Point of operation guarding specified in 1910.212 (a) (3) by using two hand tripping devices and electronic safety devices specified in 1910.212 (a) (1) Types of guarding.

In accordance with 29 CFR 1910.212 (a) (3) (ii) and Directive 2006/42/EC of the European Parliament, the electronic controllers located in the 2000X t/ea/d Power Supply have been designed in accordance with the requirements of:

EN 954 Safety related parts of control systems (Category 3), ISO 13851 Two-hand control devices (Type IIIB), EN/IE C 60204-1 Electrical equipment of machines (Type III)

and

NFPA 79 Electrical Standard for Industrial Machinery 1997 Edition (Type 3).

These standards require concurrent actuation of the two control devices (start switches) by both hands (within a specified time) during the hazardous condition. Machine operation ceases upon release of either one or both of the control devices when the hazardous condition is still present. Both control devices must be released before operation can be re-initiated.

If the 2000X Series Actuator or Stand is not used with dual start switches, mounted in a Series 2000X Base, then it may not be in compliance with OSHA requirements unless some other means of safety actuation or guarding has been provided.

An additional requirement of Section 1910.212 (b) is that the machine must be securely anchored to prevent walking or moving.

1.3 Warranty

For warranty information please reference the warranty section of Terms and Conditions found at: www.emerson.com/branson-terms-conditions.

1.4 How to Contact Branson

Branson is here to help you. We appreciate your business and are interested in helping you successfully use our products. To contact Branson for help, use the following telephone numbers, or contact the field office nearest you.

Brookfield:

- Brookfield Main Number (all Departments): (203) 796-0400 (Eastern Time Zone)
- Parts Store (direct number): (877) 330-0406 (Central Time Zone)
- Repair department: (877)-330-0405 (Central Time Zone)
- For emergency after-hours service (5pm-8am Est): (203) 796-0500 (US phone numbers only).

Shanghai:

- Main Number: 86 21 3781 9600

Tell the operator which product you have and which person or department you need ([Table 1.1 Branson Contacts](#)). If after hours, please leave a voice message with your name and return telephone number.

1.4.1 Before Calling Branson for Assistance

This manual provides information for troubleshooting and resolving problems that could occur with the equipment (see [Chapter 7](#)). If you still require assistance, Branson Product Support is here to help you. To help identify the problem, use the following questionnaire which lists the common questions you will be asked when you contact the Product Support department.

Before calling, determine the following information:

1. Your company name and location.
2. Your return telephone number.
3. Have your manual with you. If troubleshooting a problem, refer to [Chapter 7](#).
4. Know your equipment model and serial numbers (found on a gray data label on the units). Information about the Horn (part number, gain, etc.) or other tooling may be etched into the tooling. Software- or firmware-based systems may provide a BOS or software version number, which may be required.
5. What tooling (horn) and booster are being used?
6. What are the setup parameters and mode?
7. Is your equipment in an automated system? If so, what is supplying the "start" signal?
8. Describe the problem; provide as much detail as possible. For example, is the problem intermittent? How often does it occur? How long before it occurs if you are just powering up? If an error is occurring, which error (give error number or name)?
9. List the steps you have already taken.
10. What is your application, including the materials being processed?
11. Have a list of service or spare parts you have on hand (tips, horns, etc.)
12. Notes:

1.5 Returning Equipment for Repair

Before sending equipment for repair, provide as much information with the equipment to help determine the problem with the system. Fill in any details below or on a separate sheet.

Describe the problem; provide as much detail as possible. For example, is this a new problem? Is the problem intermittent? How often does it occur? How long before it occurs if you are just powering up?

| NOTICE | |
|---|---|
|  | To return equipment to Branson, you must first obtain an RGA number from a Branson representative, or the shipment may be delayed or refused. |

If you are returning equipment to Branson for repair, you must first call the Repair department to obtain a Returned Goods Authorization (RGA) number. (If you request it, the repair department will fax a Returned Goods Authorization form to fill out and return with your equipment.)

Branson Repair Department, C/O Zuniga Logistics, LTD
12013 Sara Road, Killam Industrial Park
Laredo, Texas 78045 U.S.A.
direct telephone number: (877) 330-0405
fax number: (877) 330-0404

- Provide as much information as possible that will help identify the need for repair.
- Carefully pack the equipment in original packing cartons.
- Clearly label all shipping cartons with the RGA number on the outside of cartons as well as on your packing slip, along with the reason for return.
- Return general repairs by any convenient method. Send priority repairs by air freight.
- You must prepay the transportation charges FOB Laredo, Texas, U.S.A.

1.5.1 Get an RGA Number

RGA# _____

If you are returning equipment to Branson, please call the Repair Department to obtain a Returned Goods Authorization (RGA) number. (At your request, the Repair Department will fax an RGA form to fill out and return with the equipment.)

1.5.2 Record information about the Problem

Before sending equipment for repair, record the following information and send a copy of it with the equipment.

This will greatly increase Branson's ability to address the problem.

1. Describe the problem; provide as much detail as possible.
For example, is the problem intermittent? How often does it occur? How long before it occurs after powering up?

2. Is your equipment in an automated system? NO / YES
3. If the problem is with an external signal, which signal? _____
If known, include plug/pin # (e.g., P29, pin #3) for that signal: _____
4. What are the Weld Parameters?

5. What is your application? (Type of weld, plastic material, etc.)

7. Contact the Branson office prior to shipping the equipment.
8. For equipment not covered by warranty, to avoid delay, include a Purchase Order.

Send a copy of this page with the equipment being returned for repair.

1.5.3 Departments to Contact

Call your local Branson Representative, or contact Branson by calling, and asking for the appropriate department as indicated in [Table 1.1 Branson Contacts](#) below.

Table 1.1 Branson Contacts

| What you need help with or information about | Whom to Call | At this Phone |
|---|--|-------------------------|
| Brookfield | | |
| Information about new welding systems or components | Your local Branson Rep or Branson Customer Service | 203-796-0400 Ext 384 |
| Application and Setup questions on the welding system | Welding Applications Lab | 203-796-0400 Ext 368 |
| Application assistance on the Horns and Tooling | ATG Lab | 203-796-0400 Ext 495 |

Table 1.1 Branson Contacts

| What you need help with or information about | Whom to Call | At this Phone |
|---|---------------------------|-------------------------|
| Technical questions about the welding system | Welding Product Support | 203-796-0400 Ext 355 |
| Technical questions about Horns and Tooling | ATG Lab | 203-796-0400 Ext 495 |
| Ordering new parts | Parts Store | 877-330-0406 |
| RGA's, Request for Repair, Status of a Repair | Welding Repair Department | 877-330-0405 |
| System Automation/ hookup Information | Product Support | 203-796-0400 Ext 355 |
| Shanghai | | |
| All matters | All departments | 86-21-3781-0588 |

My Local Branson Representative's name is:

I can reach this representative at:

1.5.4 Pack and Ship the Equipment

- Carefully pack the system in original packing material to avoid shipping damage. Plainly show the RGA number on the outside of cartons as well as inside the carton along with the reason for return.
Make a list of all components packed in the box. **KEEP YOUR MANUAL.**
- Return general repairs by any convenient method. Send priority repairs by air freight. Prepay the transportation charges FOB the repair site.

| NOTICE | |
|---|--|
|  | Items that are sent Freight Collect will be refused. |

1.6 Obtaining Replacement Parts

You can reach Branson Parts Store at the following telephone numbers:

Branson Part Store

direct telephone number: 877-330-0406

fax number: 877-330-0404

Many parts can be shipped the same day if ordered before 2:30 p.m., Eastern time.

Shanghai

direct telephone number: 86-21-3781-0588.

A parts list is found in [Chapter 7](#) of this manual, listing descriptions and EDP part numbers. If you need replacement parts, coordinate the following with your purchasing agent:

- Purchase order number
- 'Ship to' information
- 'Bill to' information
- Shipping instructions (air freight, truck, etc.)
- Any special instructions (for example, "Hold at the airport and call"). Be sure to give a name and phone number
- Contact name information

1.7 Disposing Obsolete Machines and Accessories

Branson Ultrasonics is not responsible for the disposal of used machines and accessories. Branson Ultrasonics is willing to take back used machines or accessories and to dispose them properly. It is required that the corresponding parts meet the following conditions:

- They were delivered by Branson Ultrasonics,
- They are returned free of product residue and harmful substances (confirmed in writing), and
- They are delivered free of charge to Branson Ultrasonics.

Please observe the valid regulations when you dispose of the used machines and accessories.

Chapter 2: The 2000X Distance Power Supply

| | | |
|------------|--|-----------|
| 2.1 | Models Covered | 14 |
| 2.2 | Overview of these Models | 15 |
| 2.3 | Compatibility with Branson Products | 16 |
| 2.4 | Features | 17 |
| 2.5 | Front Panel Controls | 21 |
| 2.6 | Welding Systems | 22 |
| 2.7 | Glossary | 23 |

This manual provides detailed instructions for installation, setup, operation, and maintenance of the 2000X Power Supply. For detailed information on operation and maintenance of other components connected to the Power Supply, refer to appropriate Actuator instruction manual.

This Power Supply contains a microprocessor-based controller that provides for control and monitoring of welding operations.

2.1 Models Covered

This manual covers the 2000Xd Power Supply with the digital UPS configuration.

2.1.1 Power Supply Manual and Guides

The following documentation is available for the Branson 2000Xd Power Supply:

- 2000X distance (EDP 100-412-167)
- 2000-Series System Installation Guide (EDP 100-214-226)
- 2000X distance Quick Start User's Guide (EDP 100-412-169)

2.1.2 Actuator Manuals

The following documentation is available for the Branson Actuators compatible with this power supply:

- 2000X aed Actuator Instruction Manual (EDP 1019572)

2.2 Overview of these Models

The 2000X generates ultrasonic electrical energy through an ultrasonic converter for welding plastics. Several models are available, depending on the desired frequency (for example, 20 kHz) or the desired power range (for example, 2.5 kW). The Power Supply also contains a microprocessor-based controller module that provides for control and monitoring of welding operations.

The Power Supply provides the following features:

- **AutoTune with Memory (AT/M):** Allows the Power Supply to track and store the horn frequency of the last weld.
- **Auto Seek:** Tracks and starts the horn on the correct frequency. It does this by running the horn at a low-level amplitude (5%) to find and lock on to the horn operating frequency.
- **Line Regulation:** Maintains converter amplitude by regulating for variances in the line voltages.
- **S-Beam Load Cell:** Provides an indication of the force on a part during a weld. This indication can be used to determine when to trigger ultrasonics and also to produce a force/distance graph of the operating cycle.
- **Load Regulation:** Maintains converter amplitude over the full range of rated power.
- **System Protection Monitor:** Protects the Power Supply by providing five levels of protection.
 1. Voltage
 2. Current
 3. Phase
 4. Temperature
 5. Power
- **Select Start:** Provides four starting ranges. Select Start in the Analog UPS allows the Power Supply to ramp up amplitude at four different rates to accommodate different horn and load requirements. Select Start in the Digital UPS allows Memory and Timed Seek to be turned on or off, and allows a range of time values to be input for Ramp Time(s) and Seek Time(s).
- **Frequency Offset:** Provides for applying an external frequency offset to the operating frequency.

2.3 Compatibility with Branson Products

The 2000X Power Supply is designed to be used with:

- 2000X aed Actuator (Actuator alone, or Actuator Stand on a Base or on a Hub)

Table 2.1 Power Supply Compatibility with Branson Converters

| 2000X Model | Converter |
|---------------|-----------|
| 15 kHz/3300 W | CJ15 |
| 20 kHz/1250 W | CJ20 |
| 20 kHz/2500 W | |
| 20 kHz/4000 W | |
| 30 kHz/750 W | CJ30 |
| 30 kHz/1500 W | |
| 40 kHz/400 W | 4TJ |
| 40 kHz/800 W | |

2.4 Features

2.4.1 The Welding System

The welding system consists of a Power Supply and a converter-booster-horn stack. The system can perform ultrasonic welding, inserting, staking, spot welding, swaging, and degating. It is designed for automated, semi-automated and/or manual production operations.

Listed below are the control features of the Branson 2000X-series ultrasonic welding system.

- **1 Millisecond Control and Sampling Rate:** This feature provides sampling and control of the weld process 1000 times each second.
- **16 Presets:** User-configurable setups that can be preset allowing you to simply recall a weld setup to start production.
- **19" Rack Mount Enclosure:** Compatible with industry standard 19" rack enclosure systems. Rack mount handles are available as an optional kit.
- **Actuator Clear Output:** Output for automation so material handling can start before horn is fully retracted.
- **Adjust While Running:** The 2000X allows you to modify the weld parameters while the welder is running. This can be of benefit in automated systems where you do not want to shut down the entire line to make a minor modification.
- **Afterburst:** This feature allows you to turn on the ultrasonics after the weld and hold steps to reliably release parts from the horn.
- **Alarms, Process:** These are set values used for part quality monitoring.
- **Amplitude Stepping:** A Patented Branson Process. At a specified time, energy, peak power, distance, or by external signal you can change the amplitude during the weld to control the flow of plastic. This feature helps ensure part consistency, higher strength parts, and control of flash.
- **Automatic Preset Naming:** If you choose not to name your preset, the Power Supply will give it a name that describes the weld mode and main parameter setting.
- **Autotuning:** Ensures that the welder is running at peak efficiency.
- **Collapse Limits in the Collapse Mode:** Plus and minus Suspect and Reject limits can be set in the Collapse Mode.
- **Cycle Aborts:** These are user programmed conditions (missing part and ground detect) at which the cycle is terminated. These can be used as safety limits to save wear and tear on the system and your tooling.
- **Cycle Time and Date Stamp:** The Power Supply provides each cycle with a time and date stamp for production and quality control purposes. Clock is year 2000 and leap year compliant.
- **Digital Amplitude Setting:** This feature allows you to set the exact amplitude necessary for your application, affording increased range and setting repeatability over analog systems.
- **Digital Tuning:** Means to tune the Power Supply for applications and horns at the extremes of the Power Supply capture range.
- **Digital UPS:** The Digital UPS has programmable (through a digital interface from a system controller) features which allow true autotune and start ramp during set-up. Power supply presets can be customized.
- **Downspeed:** Sets the advance speed of the horn towards the workpiece.
- **Energy Compensation:** Extend the weld time up to 50% greater than the weld time setting or to whenever the min energy is reached or; shut off the weld before the expected (set) weld time if maximum energy value is reached.
- **English (USCS)/Metric Units:** This feature allows the welder to be programmed in the local units in use.
- **Foreign Languages:** Software supports user selectable languages at start up; English, French, German, Italian, Spanish, Traditional Chinese, Simplified Chinese, Japanese and Korean.

- **Frequency Offset:** This feature provides a user-set frequency value used in very limited applications where the fixture or anvil causes a frequency shift in the Power Supply's operation. This feature should be used only when advised by Branson.
- **Graphs, Auto-Scaling:** When you request a graphic printout in Time Mode, the Power Supply automatically scales the time axis of the graph to give you the most meaningful graph possible.
- **Graphs, Printing of Power, Amplitude, Velocity, Collapse, Force, Frequency, and Horn Scan for the power supply:** The 2000X supports graphic printouts of these items. These graphs include markers to show critical points in the weld. Use these graphs to optimize your weld process or diagnose application problems.
- **Graphs, User Selectable:** In any mode you can select the scale of the time axis on any graph so that you can zoom in on the start of the weld cycle.
- **Horn Down:** Clamp On: When in the horn down mode, the start switches can be released after the part is contacted while the part remains clamped in place. Press horn down key again to release. Clamp Off: The horn will retract whenever the start switches are released in the horn down mode.
- **Horn Down Display:** During Horn Down, the absolute Distance, Force, Velocity, and Pressure are displayed digitally so that you can determine correct values for process limits and cutoffs.
- **Horn Down Mode:** A manual procedure used to verify system setup and alignment.
- **Horn Scan:** A scan to enhance selection of operating frequency and control parameters.
- **Limits, Control:** These are controls that are used in conjunction with the main weld mode. These user programmed limits provide for additional control of the weld process.
- **Limits, Reject:** A class of user-definable process alarms that alert you if a part falls into a range that you classified as reject parts.
- **Limits, Suspect:** A class of user-definable process alarms that alert you if a part falls into a range that you have determined should be inspected.
- **Memory:** When Memory is turned on, weld parameters at the end of the cycle will be entered.
- **Parallel Port:** The parallel port supports printers.
- **Parameter Entry through Keypad:** A keypad is provided for direct entry. Plus (+) and Minus (-) keys are provided for adjusting existing values.
- **Parameter Range Checking:** If you enter an invalid parameter the Power Supply shows you the valid range.
- **Password Protection:** This feature allows you to secure your setup from unauthorized changes. You can select your own password.
- **Presets:** The Digital UPS is capable of storing presets of power supply operating parameters depending on feature level and type of UPS.
- **Pretrigger:** This feature allows you to turn on the ultrasonics before contact with the part to increase performance.
- **Print, Background:** This feature allows you to print the results of the previous cycle while performing a new cycle.
- **Print, Data:** Prints one line of data depicting weld results.
- **Print, Now:** At any time you can request any printable items for the last cycle completed.
- **Print, on Alarm:** You can request any printable item whenever an alarm occurs. This gives you the information you need to determine how your setup or limits can be changed.
- **Print, on Sample:** You can request any printable items based on a sampling rate. This facilitates auditing your process and lot control.
- **Printing, Weld History:** At any time you can print all of the weld parameters from the last 50 cycles completed using your current setup.
- **Rapid Traverse:** Allows a high horn travel speed for a portion of the stroke. Once the set distance is reached, travel speed is reduced to the downspeed setting.
- **Ramp Starting:** The starting of the Power Supply and horn is done at the optimum rate to reduce electrical and mechanical stress on the system.

- **Seek, Post Weld:** This feature provides a Seek at the end of the cycle to automatically retune the Power Supply.
- **Seek:** Ensures operation at resonance; minimizes tuning errors; and operates the stack at low amplitude (approximately 5%), then provides a means of sensing and storing the resonant operating frequency value.
- **Setup Checking:** If you create a setup with conflicts the Power Supply notifies you of the specific conflict.
- **Short Cut to Modify Main Parameters:** From the Run Screen you can jump to a screen to make modifications to your main parameters. This simplifies minor adjustments.
- **Start-up Diagnostics:** At start-up, the controls test the major system components.
- **System Information Screen:** This is a screen that will give you information about your welding system.
Refer to this screen when contacting Branson for service and support.
- **Test Diagnostics:** In Test mode you can view the ultrasonic system results using digital readouts and bar graphs.
- **Timed Seek:** When turned ON, will do a Seek once every minute to update horn resonant frequency to memory. This is especially useful when the welding process affects the actual temperature of the horn, causing a resonant frequency shift.
- **User-Nameable Presets:** You can refer to each preset by name or part number making identification of your presets simple.
- **View Weld Results:** From the Run Screen you can view any of the information available from the last completed cycle.
- **Weld Modes:** Time, Energy, Peak Power, Absolute, Collapse, and Ground Detect. The 2000X welder offers multiple weld modes so that you can choose the mode of control that best meets your specific application need.

2.4.2 The Power Supply

The Power Supply consists of an ultrasonic Power Supply module and a system controller. The ultrasonic Power Supply module converts conventional 50/60 Hz line current to 20 kHz, 30 kHz or 40 kHz electrical energy. The system controller controls the welding system.

The power supply is configured with either an analog or digital UPS. The analog supply has one preset which calls up the factory default setting.

The digital supply has a library of up to 18 locked presets which are accessible for various process parameter modifications that are unique to the power supply itself. These modifications can be named to reflect specific applications, and are loaded into memory prior to shipment from the Branson Factory. The parameters of the individual presets can be modified by a Branson representative. Initially, one preset is set to factory default. They are accessed via an RS-232c link to the system controller.

2.4.3 The Actuator

The Actuator is an electro-pneumatic system that contains the Ultrasonic Stack (Converter/Booster/Horn) that delivers the force and ultrasonic energy to the workpiece. The pneumatics are enclosed in the upper half of the actuator, and also contains a S-Beam Load Cell, and an encoder.

The Converter

The converter is mounted in the actuator as part of the ultrasonic stack. The ultrasonic electrical energy from the power supply is applied to the converter (sometimes called the transducer). This transforms the high frequency electrical oscillations into mechanical vibrations at the same frequency as the electrical oscillations.

The heart of the converter is piezoelectric ceramic elements. When subjected to an alternating voltage, these elements alternately expand and contract, resulting in better than 90% conversion of electrical to mechanical energy.

The Booster

Success in ultrasonic assembly depends on the right amplitude of movement at the horn face. Amplitude is a function of horn shape, which is largely determined by the size and form of the parts to be assembled. The booster can be used as a mechanical transformer to increase or decrease the amplitude of vibrations applied to the parts through the horn.

The booster is a resonant half-wave section of aluminum or titanium. It is mounted between the converter and the horn, as part of the ultrasonic stack. It also provides a clamping point for rigid stack mounting.

Boosters are designed to resonate at the same frequency as the converter with which they are used. Boosters are usually mounted at a nodal (minimum vibration) point of axial motion. This minimizes the loss of energy and prevents vibration from being transmitted into the actuator.

The Horn

The horn is selected or designed for a specific application. Each horn is tuned typically as a half-wave section that applies the necessary force and vibration uniformly to the parts to be assembled. It transfers ultrasonic vibrations from the converter to the workpiece. The horn is mounted to the booster as part of the ultrasonic stack.

Depending on their profile, horns are referred to as stepped, conical, exponential, bar, or catenoidal. The shape of the horn determines the amplitude at the face of the horn. Depending on the application, horns can be made from titanium alloys, aluminum, or steel. Titanium alloys are the best materials for horn fabrication due to their high level of strength and low loss. Aluminum horns are usually chrome- or nickel-plated or hard-coated to reduce wear. Steel horns are for low amplitude requiring hardness, such as ultrasonic insertion applications.

S-Beam Load Cell and Dynamic Follow Through

The S-Beam Load Cell measures the force being applied to the part to trigger ultrasonics and record the welding parameters. The load cell assembly ensures that pressure is applied to the part prior to the application of ultrasonic energy.

To maintain horn-to-part contact and force as the joint collapses, the S-Beam Load Cell assembly provides dynamic follow-through. As the plastic melts, the load cell assembly ensures smooth transmission of ultrasonic energy into the part.

Encoder

The encoder measures the distance the horn has travelled. Depending on the power supply settings, it can:

- Allow for distance welding in absolute and collapse modes
- Detect improper setup controls
- Enhances control of the quality of the weld

2.5 Front Panel Controls

Figure 2.1 2000X distance Power Supply Front Panel Display after Power-Up

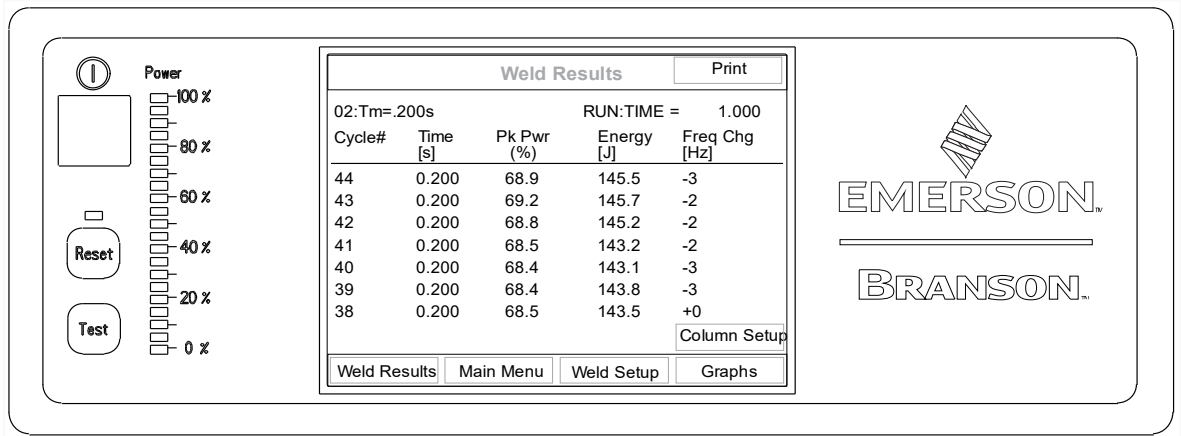

- Power Bar Graph: Indicates the percentage of rated power delivered either during the last weld cycle or when Test is running. The indicator's scale can be increased for low-power settings.
- Power: Press to turn the system On and Off. When you depress the button, it lights to indicate power is On.
- Reset: Press to clear alarms. Reset only functions on the Run screen.
- Test: Press to display a menu you can use to test the ultrasonic power supply, horn, booster, and converter.
- Weld Results: Press to view 4 preselected parameters for the last 7 weld cycles.
- Main Menu: Press to return to the Main Menu.
- Weld Setup: Press to go to the Setup menu.
- Graphs: Press to select to view and/or print graphs of Power, Amplitude, Velocity, Frequency, Distance, Auto Scale, or X Scale.

2.6 Welding Systems

2.6.1 Principle of Operation

Thermoplastic parts are welded ultrasonically by applying high frequency vibrations to the parts being assembled. The vibrations, through surface and intermolecular friction, produce a sharp rise in temperature at the welding interface.

When the temperature is high enough to melt the plastic, there is a flow of material between the parts. When the vibrations stop, the material solidifies under pressure and a weld results.

Most plastics welders operate at a frequency above the range of human hearing (18 kHz) and are thus called ultrasonic.

2.6.2 Weld System Applications

2000X weld systems can be used for the following applications:

- Ultrasonic welding
- Cutting and sealing thermoplastic fabric and film
- Staking, spot welding, swaging, and degating thermoplastic parts
- Other ultrasonic processing applications

2.7 Glossary

The following terminology may be encountered when using or operating a 2000X-series ultrasonic welding system. Some of these terms may not be available in all Controls (Power Supply model) configurations:

AB Amplitude: The amplitude at the horn face during the afterburst step.

AB Delay: Time delay between the end of the hold and the start of afterburst.

AB Time: The time duration of the afterburst.

Abort Current Printing: Terminates the current printing request.

Absolute Cutoff: Ends the ultrasonic portion of the cycle when the set parameter is reached.

Absolute Distance: The distance the horn has travelled from home.

Absolute Mode: A mode of operation in which the weld is terminated when a user-specified distance from the home position has been reached.

Absolute Position: The position of the Actuator from the home position.

Accept-as-is: A disposition permitted for a nonconforming item when it can be established that the item is satisfactory for its intended use without violating safety or functional requirements.

Actual: A reported value that occurred during the weld cycle. The converse is the set parameter that was requested during the setup.

Act Clr Output: Actuator Clear output signal, sent upon the welder reaching a safe position of the actuator return stroke. Used in automated systems.

Actuator: The unit that houses the converter, booster, and horn assembly in a rigid mounting allowing it to move up and down either mechanically or pneumatically to apply a predetermined pressure on the workpiece.

Adjust While Running: Allows modifications to weld parameters while the welder is running.

Afterburst: Ultrasonic energy applied after the hold step. Used to break away sticking parts from the tooling.

Alarm Beeper: An audible signal that sounds when a general alarm has occurred.

Amplitude: The peak-to-peak movement at the horn face. Always expressed as a percentage of the maximum.

Amp A: The amplitude applied to the part from the start of the weld to the step change.

Amp B: The amplitude applied to the part from the step change to the end of the weld.

Amplitude Graph: A graph of amplitude percentage plotted against time.

Amplitude Step: A change in amplitude during the ultrasonic portion of the cycle.

Amp Control: The ability to set amplitude digitally or by an external control.

Automatic: A pretrigger condition indicating that pretrigger engages when the actuator leaves the upper limit switch.

Auto Scale Graph: When turned on, the graph will be auto scaled, when off allows X Scale to set scale.

Baud Rate: The rate of data transmission over the serial communication port.

Beep: An audible signal produced by the Branson control board. Used to alert the operator to an unexpected condition or that trigger has been reached.

Booster: A one-half wavelength long resonant metal section mounted between the converter and horn, usually having a change in cross-sectional area between the input and output surfaces. Mechanically alters the amplitude of vibration at the driving surface of the converter.

Cal Sensor: The menu title for accessing the calibration and verification of pressure and force.

Cal Actuator: Calibrate Actuator. Menus to guide the user through actuator calibration, including distance.

Clamping force: The pressure exerted by the horn on the workpiece.

Cold Start: A user operation to establish a setup to a new, initial minimum set of weld parameters. Found in the Diagnostics menu. Warning: Use carefully.

Collapse Distance: The vertical distance your part will be collapsed before termination of ultrasonics.

Collapse Distance Graph: A graph of collapse distance plotted against time.

Collapse Mode: A mode of operation in which the weld is terminated when the part has been collapsed by a user-specified distance.

Control Limits: An automatic weld energy compensation option. Normal weld parameters are automatically increased, up to user-defined control limits, if specified minimum weld parameters are not reached initially. Other control limit functions are Collapse Cutoff, Absolute Cutoff and Peak Power Cutoff.

Counters: A record of the number of cycles run by category, for example, alarms.

Custom Actuator: Allows the voltage to be set to either 0V or 24V for Ground Detect and Upper Limit Switch.

Cycle Aborts: Settings that end the cycle immediately.

Digital Filter: A smoothing technique used to provide more meaningful graph data.

Downspeed: The rate of speed of the actuator from the home position to the part.

Energy Braking: Allows the power supply time to reduce the amplitude before the sonics are shut off. Any overloads that occur will be ignored in this state. They will be handled in the hold state.

Energy Compensation: Extend the weld time up to 50% greater than the weld time setting or whenever the minimum energy is reached, or shut off the weld before the expected (set) weld time if the maximum energy value is reached.

Energy Mode: A mode of operation in which ultrasonics are terminated at a user-specified energy value.

External Amplitude Control: Enables you to access real-time amplitude control directly.

External Frequency Control: Enables you to access real-time frequency control directly.

External U/S Delay: If External Trigger Delay is enabled, weld state machine shall wait for external trigger delay input to become active in less than 30 seconds. When the time expires and input is still inactive, alarm will be recorded and cycle aborted.

Extra Cooling: When On, allows cooling air to start when upper limit switch is triggered and remains on throughout the cycle. When Off, air is applied at ultrasonics application.

F Actual: Actual Frequency. The operating frequency of the ultrasonic stack, as measured during a cycle.

F memory: Frequency as stored in Memory. The intended operating frequency value for an ultrasonic stack, stored in the memory of the power supply.

Force Act: Actual Force. The measured mechanical force determined from the results of a weld cycle.

Force Set: Displays the Force as set in the Setup menu.

Force Step: A change in mechanical force during the cycle.

Force: Weld Force. The mechanical force applied to the part during the cycle.

Force/Col Graph: Dual display of collapse distance in inches and force in pounds as a function of time.

Force Graph: Displays force in pounds as a function of weld time.

Form Feed: A form feed is inserted after print setup or print graph, or after the number of lines per page is reached.

Freq Chg: Frequency Change. (Frequency at Start versus Frequency at End).

Freq End: Frequency at End. Frequency at the time ultrasonics was turned off.

Freq Max: Maximum Frequency. Highest frequency reached during weld cycle.

Freq Min: Minimum frequency. Lowest frequency reached during weld cycle.

Freq Start: Frequency at Start. Frequency at the time ultrasonics was turned on.

Frequency Graph: Displays operating frequency as a function of time.

Frequency Offset: An offset factor applied to the ultrasonic frequency output set in the power supply.

F Actual: The actual running frequency of the acoustic system.

F Memory: The frequency stored in the Power Supply memory.

General Alarm: An alarm that occurs due to a system fault and/or tripping a limit.

Ground Det. Cutoff: Immediately terminates the weld process, including the hold step, when a ground detect has occurred.

Ground Detect Mode: In this mode of operation, ultrasonics are terminated after detection of a ground condition between the horn and fixture or anvil.

Hand Held Actuator: An actuator that is usually operated using a manual trigger start switch, and will run in Time, Energy, Peak Power or Ground Detect mode. It is sometimes used in automation.

Hold Force: The mechanical force on the part during the Hold portion of the weld cycle.

Hold Time: The duration of the hold step.

Horn Down: A mode in which ultrasonics are locked out and the user can advance the Actuator for setup and alignment.

Host Commands: The host interface uses the 9-pin external RS-232c connector to connect system controller to the host PC. Transmit and receive messages define a master-slave protocol in which the host is the master.

Linear Encoder: Provides carriage distance measurement during the Actuator cycle.

Main Menu: The list of categories of features available in the software.

Max Energy: The maximum user-specified energy that produces a part without an alarm. Used with energy compensation to turn off the weld in Time mode.

Min Energy: The minimum user-specified energy that produces a part without an alarm. Used with energy compensation to extend the weld to up to 50% of the weld time in Time mode.

Minus Limit: The user-defined lower limit - used with suspect and reject limits.

Missing Part: A min/max distance where trigger is expected. Returns the actuator to the home position and displays an alarm indicating that the cycle was aborted because no part was present.

Parameter range: Valid range of parameters accepted for a particular setup.

Password: A user-defined access code for entry into secure areas of the user software.

Password protection: Enables lock-out of weld parameter modification by using a user-defined password.

P/Col Graph: Dual Display of % power and collapse distance as a function of time.

Peak Power Cutoff: A power value that terminates the ultrasonics when peak power is not the primary control mode.

Peak Power Mode: A mode of operation in which ultrasonics are terminated at a user-specified power value in percentage of maximum.

Peak Power: A weld mode in which obtaining a power value (percentage of full power) will cause the ultrasonic energy to terminate.

P/Force Graph: Dual display of % power and force as a function of time.

Pneumatic Air Prep: This is a panel that mounts the cutoff valve, the slow start valve, the regulator and the two filters that are normally located in the actuator. This panel is required for installations where the actuator is not positioned in a vertical plane, or is used without a Branson actuator support.

Post Weld Seek: A low level (5%) amplitude running of the Power Supply after hold or afterburst for the purpose of storing a frequency to memory.

Power Graph: A graph of power in percentage of maximum plotted against time.

Preset: User-stored parameters constituting a weld setup. Saved in non-volatile memory in the power supply, can be recalled for quick Setup of the system.

Presets, External Selection: Presets can be changed externally using 4 user inputs on the user I/O connector. Presets 1 through 16 are available for d levels, 1 - 12 for ea, and 1 - 2 for the t level.

Preset name: The ability to name a preset in customer-defined terms.

Pretrigger: The setting that causes ultrasonics to start before contact with the part.

Pretrg Amp: The amplitude at the converter during pretrigger.

Pretrg @ D: The distance at which pretrigger is turned on.

Print Data/Graphs: Using the optional printer, shows a list of data reports and graphs that can be printed by the user.

Print on Alarm: Allows the user to set up printing automatically when an alarm occurs.

Print on Sample: Allows the user to set up printing automatically based on the number of cycles performed.

Rapid Traverse/RAPID TRAV: Allows fast actuator descent to a user-defined point, before the Downspeed value is applied for control during the stroke.

Ready Position: State in which the welder is retracted and ready to receive the start signal.

Recall Preset: Allows a user to recall a preset from memory for purposes of operation or modification.

Reject Limits: User-definable limits at which the violating cycle is identified as having produced a bad part.

Required: State used with limits indicating that a reset will be required when the limit is exceeded. The reset is accomplished by using the reset key on the front of the Power Supply, or by external reset at the User I/O.

Reset Required: State used with alarms indicating that a reset will be required before a cycle can be run. The reset is accomplished by using the reset key on the front of the Power Supply, or by external reset at the User I/O.

S-Beam Load Cell: Provides force measurement for accurate ultrasonic triggering and graphing of force.

Save Preset: Stores a programmed set of weld parameters as a preset.

Scrub Time: The amount of time after detection of a ground condition to the termination of ultrasonics.

Seek: A setting where ultrasonics are on at 5% amplitude for the purpose of finding the resonant frequency of the stack.

Serial Port: A RS-232c port provided to you for external data communications.

Stack: Converter, Booster, and Horn.

Step @ T (S): User-definable time at which Amp A or Force A is changed to AmpB or Force B.

Step @ E (J): User-definable energy at which AmpA/Force A is changed to AmpB/Force B.

Step @ Pwr (%): User definable power at which AmpA/Force A is changed to AmpB/Force B.

Step @ Col (in): User-definable collapse distance at which AmpA/Force A is changed to AmpB/Force B.

Step @ Ext Sig: Allows you to step either Force or Amplitude based upon an external signal.

Suspect Limits: User-defined limits which specify weld results used to identify a part as potentially suspect, but not necessarily enough to reject the part.

SV Interlock: SV Interlock input allows power supply to close an auxiliary door.

Test Scale: The magnification of the power bar scale on the front panel while the Test key is pushed.

Time Mode: Terminates the ultrasonics at a user-specified time.

Timeout: A time at which the ultrasonic energy terminates if the main control parameter has not been reached.

Trigger Beeper: An audible signal sounded when the trigger is made.

Upper limit switch (uls): A switch when activated indicates the actuator is in the home position.

UPS: Power Supply module.

User-defined limits: for process resultants, where – is the user-defined lower limit, and + is the user defined upper limit:

-/+ Energy: The energy reached during the weld.

-/+ Force: The force at the end of the weld.

-/+ Power: The peak power as a percentage of the maximum reached during the weld.

-/+ Time: The weld time reached during the weld.

-/+ Abs D: The absolute distance from the Home position reached during the weld.

-/+ Col D: The collapse distance reached during the weld.

-/+ Trg D: The position at which the trigger occurred.

User I/O: The User I/O is used to configure custom actuator inputs and outputs. This menu can only be entered when the welder is not in a weld cycle. There are 6 configurable inputs and 3 outputs.

Velocity Graph: A printed graph of the velocity of the actuator during descent.

View Setup: Available in Main Menu as a read only menu identical to the Weld Setup menu. It is not password protected even if the Weld Setup menu is protected.

Weld Count: Count of completed weld cycles.

Weld Energy: The energy specified to be applied to the part during the weld cycle.

Weld Force: The force at the end of the weld cycle.

Weld History: The last 50 weld summary data lines that are saved and can be printed.

Weld Scale: The magnification of the power bar scale on the front panel during a weld cycle.

Weld State: A screen message showing the current state of the welder during or before the process. The list of messages are shown in the Run Screen section.

Weld Summary Data: A one-line summary of information associated with the last weld cycle.

Weld Time: The time for which ultrasonics are on.

Write In Fields: Assign a unique 10 digit alphanumeric to a specific weld setup and cycle.

X Scale Graph: Allows a scaling factor to be applied when auto scale is turned off.

Chapter 3: Delivery and Handling

| | | |
|------------|--|-----------|
| 3.1 | Shipping and Handling | 30 |
| 3.2 | Receiving | 31 |
| 3.3 | Unpacking | 32 |
| 3.4 | Returning Equipment | 33 |

3.1 Shipping and Handling

| CAUTION | |
|---|---|
|  | <p>The Power Supply internal components are sensitive to static discharge. Many components can be harmed if the unit is dropped, shipped under improper conditions or otherwise mishandled.</p> |

3.1.1 Environmental Specifications

The Power Supply is an electronic unit that converts line voltage to ultrasonic energy and controls user input for regulating the weld process. Its internal components are sensitive to static discharge, and many of its components can be harmed if the unit is dropped, shipped under improper conditions, or otherwise mishandled.

The following environmental guidelines should be respected in the shipping of the Power Supply.

Table 3.1 Environmental Specifications

| Environment | Range |
|--------------------------------|--|
| Ambient Operating Temperature | +41°F to +122°F (+5°C to +50°C) |
| Storage / Shipping Temperature | -13°F to +158°F (-25°C to +70°C) |
| Shock / Vibration (transit) | 40 g shock / 0.5 g and (3-100 Hz) vibration per ASTM 3332-88 and 3580-90 |
| Humidity | Maximum 95%* non-condensing |

*Above 40°C the humidity drops to 90%

3.2 Receiving

The Power Supply is a sensitive electronic device. Many of its components can be harmed if the unit is dropped or otherwise mishandled.

| CAUTION | |
|---|--|
|  | <p>The Actuator and the Power Supply are heavy. Handling, unpacking, and installation might require assistance or the use of a lifting device.</p> |

Scope of Delivery

Branson Power Supply units are carefully checked and packed before dispatch. It is recommended, however, that you follow the inspection procedure below after delivery.

To inspect the Power Supply when it is delivered, take the following steps.

Table 3.2 To inspect the Power Supply when it is delivered, take the following steps

| Step | Action |
|------|--|
| 1 | Verify that all parts are complete according to the packing slip. |
| 2 | Check the packing and the unit for damage (visual inspection). |
| 3 | Report any damage claims to your carrier immediately. |
| 4 | Determine if any component has become loose during shipping and, if necessary, tighten screws. |

| NOTICE | |
|---|---|
|  | <p>If the goods delivered have been damaged during shipping, please contact the forwarding agent immediately. Retain packing material (for possible inspection or for sending back the unit).</p> |

| CAUTION | |
|---|--|
|  | <p>The Actuator and the Power Supply are heavy. Handling, unpacking, and installation may require the assistance of a colleague or the use of lifting platforms or hoists.</p> |

3.3 Unpacking

The Power Supply is fully assembled. It is shipped in a sturdy cardboard box. Some additional items are shipped in the box with the Power Supply.

When unpacking the Power Supply, take the following steps:

Table 3.3 Unpacking Procedure

| Step | Action |
|--|---|
| 1 | Unpack the Power Supply as soon as it arrives. Save the packing material. |
| 2 | Inspect the controls, indicators, and surface for signs of damage. |
| 3 | Remove the cover of the Power Supply (7.7 Parts Replacement) to check if any components became loose during shipping. |
| <p>NOTICE If damage has occurred, notify the shipping company immediately. Retain packing materials for inspection.</p> | |
| 4 | Store or ship the Power Supply only within a temperature range of -22°F to +158°F (-25°C to +70°C). |

3.4 Returning Equipment

If you are returning equipment to Branson Ultrasonic Corporation, please call your Customer Service Representative to receive approval to return goods to Branson.

If you are returning equipment for repair refer to [Chapter 1: Safety and Support](#), Section [1.5 Returning Equipment for Repair](#), of this manual, for appropriate procedure.

Chapter 4: Installation and Setup

| | | |
|-------------|--|-----------|
| 4.1 | About Installation | 36 |
| 4.2 | Handling and Unpacking | 37 |
| 4.3 | Take Inventory of Small Parts | 42 |
| 4.4 | Installation Requirements | 44 |
| 4.5 | Installation Steps | 49 |
| 4.6 | Start Switch Connection (Automation) | 57 |
| 4.7 | Guards and Safety Equipment | 64 |
| 4.8 | Rack Mount Installation | 65 |
| 4.9 | Assemble the Acoustic Stack | 67 |
| 4.10 | Installing the Ultrasonic Stack in the Actuator | 72 |
| 4.11 | Testing the Installation | 75 |
| 4.12 | Still Need Help? or Parts? Have Questions? | 76 |

4.1 About Installation

This chapter is intended to help the installer with the basic installation and setup of your new 2000X-series welder. This chapter will bring the reader to the point at which the system is functionally “ready to weld”.

| CAUTION | |
|---|--|
|  | The Actuator and related components are heavy. Handling, unpacking, and installation can require help or the use of lifting platforms or hoists. |

International safety labels are found on the power supply and the actuator as well. Those that are of importance during Installation of the system are identified in the figures in this and other chapters of the manuals.

4.2 Handling and Unpacking

If there are any visible signs of damage to the shipping containers or the product, or you later discover hidden damage, NOTIFY YOUR CARRIER IMMEDIATELY. Save the packing material.

1. Unpack the 2000X-series components as soon as they arrive. Refer to the following procedures.
2. Verify you have all of the equipment ordered. Some components are packed inside other boxes.
3. Inspect the controls, indicators, and surfaces for signs of damage.
4. Save all packing material, including the pallets and wood spacer blocks.

4.2.1 Unpack the Power Supply

Power supplies are shipped in a cardboard carton. It weighs approximately 40 lbs.

1. Open the box, remove the two foam top packing halves and lift the power supply out.
2. Remove the toolkit(s) and other components shipped with the power supply. These items may be shipped in small, separate boxes, or underneath the power supply in the box.
3. Save the packing material; evaluation systems will be returned using this packing material.

4.2.2 Unpack the Stand or Actuator

The stand (or actuator) is heavy and packed in a protective shipping container. The actuator toolkit is packed with the actuator. A booster, converter and other components may be packed inside the shipping container (depending on the equipment ordered).

- Stands are shipped on a wooden pallet with a cardboard box cover.
- Actuators (alone) are shipped in a rigid cardboard box using protective foam shells for support.

Figure 4.1 Linear Encoder is sensitive; Do Not Handle it!

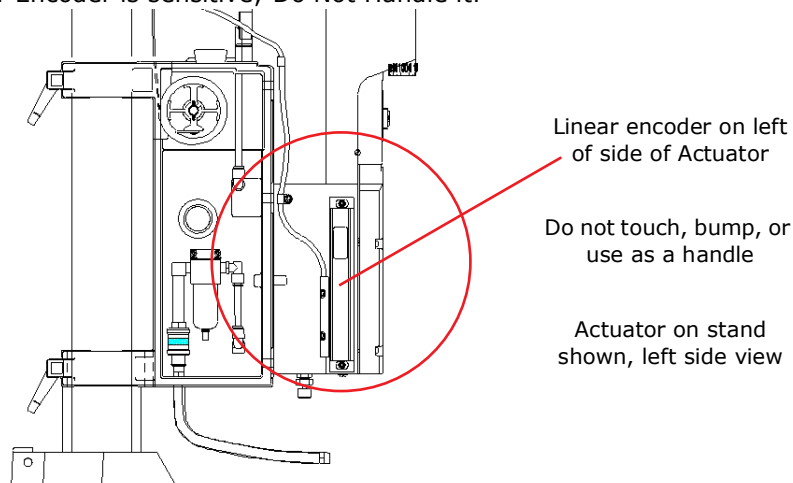

| CAUTION | |
|---|--|
|  | <p>The linear encoder (on the left side of the actuator) is very sensitive. Do not use the linear encoder assembly as a hand-hold, allow no impact on it, and do not place any weight on it.</p> |

Depending on which one of the following options applies to you, unpack the Branson actuator assembly:

4.2.3 Stand (actuator on a base)



| CAUTION | |
|---|---|
|  | <p>Heed the "This End Up" arrows and the "Open Top First" instructions. The packaging is designed to be removed from the assemblies from an upright orientation only.</p> |

Figure 4.2 Unpacking the Stand (Actuator on a Base); right-side view of Stand

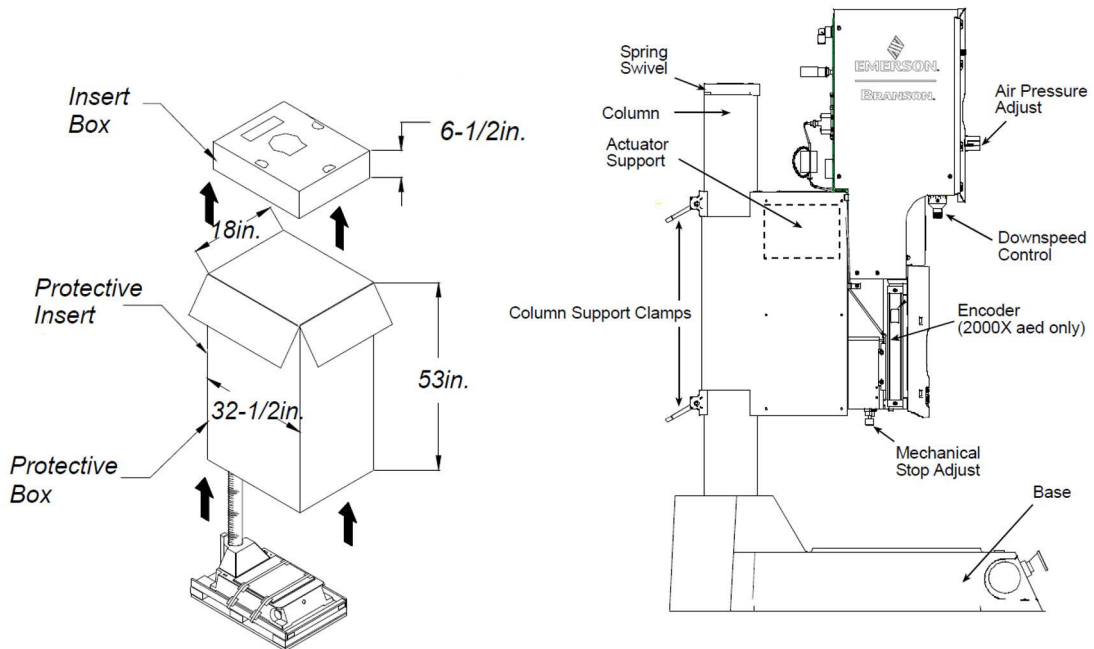

1. Move the shipping container close to the intended installation location, leave it on the floor.
2. Open the top of the box. Remove the insert from the top of the protective box.
3. Remove the staples at the bottom of the protective box. Lift the protective box off the pallet.
4. Remove the protective insert around the actuator.

| CAUTION | |
|---|--|
|  | <p>The column and column support are under spring tension from the counterbalance spring. Do NOT attempt to disassemble the column from the stand, but always keep the column support clamped together. When making height adjustments, carefully and slowly release the clamps to control the motion, and hold the stand to prevent sudden movements or injury.</p> |

5. Cut the two packing straps around the base and pallet. Pry off the two wooden shipping blocks (to the rear of the base) which prevent the base from sliding on the pallet.
6. The stand can now be moved into its desired location by sliding it off the pallet. Stands have a lifting hook for the use of overhead hoists to lift the assembly in place.
7. Remove the block of wood between the base and the column support by carefully loosening the two column clamps (allowing the actuator to rise slightly, but not allow sudden movements) and then cutting the shipping tape on the block of wood. **RETIGHTEN THE COLUMN CLAMPS.**
8. Unpack the toolkit from the insert box, and other parts (converter, booster, cables, manuals, etc.) that may have shipped with the stand. Save the packing material.
9. Go to Take Inventory of Small Parts. See [Table 4.1](#).

4.2.4 Stand (Actuator on a Hub)

Figure 4.3 Unpacking the Stand (Actuator on a Hub); Hub shown separately

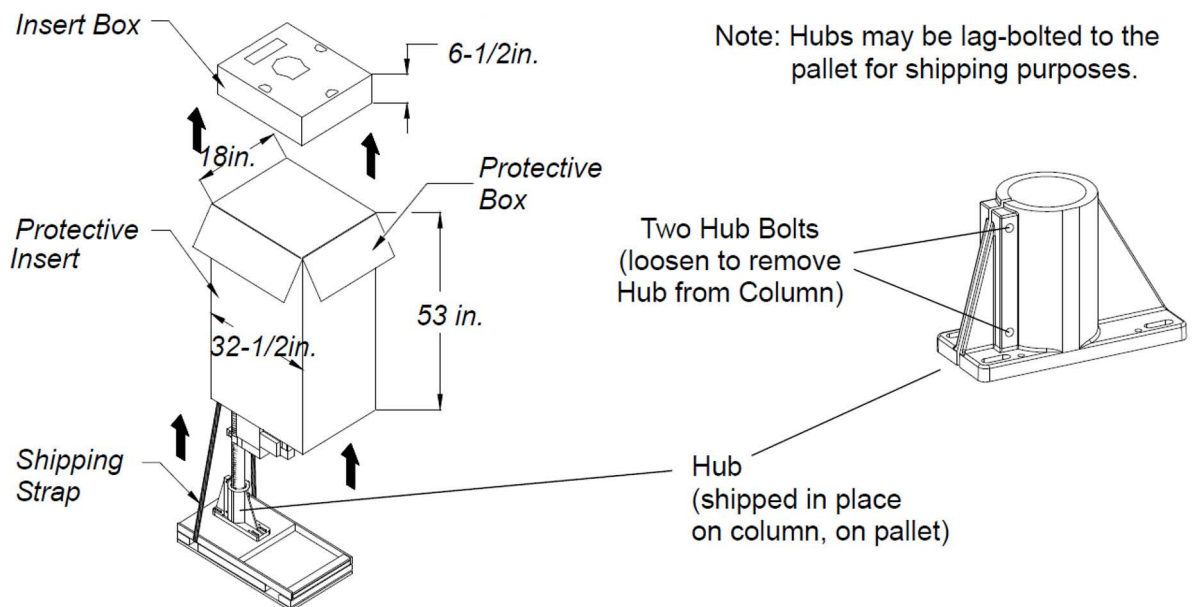

| CAUTION | |
|---|---|
|  | <p>Heed the "This End Up" arrows and the "Open Top First" instructions. The packaging is designed to be removed from the assemblies from an upright orientation only.</p> |

1. Move the shipping container close to the intended installation location, leave it on the floor.
2. Cut the two vertical packing straps, and open the top of the box. Remove the insert from the top of the box. Set the insert box aside.
3. Remove the staples at the bottom of the protective box. Lift the protective box off the pallet. Flatten the box and lay it next to the pallet (you will lay the stand on it soon).
4. Remove the protective insert around the actuator.

| CAUTION | |
|---|---|
|  | <p>The unit may tend to tip over. Stabilize the stand using the lifting hook or an assistant.</p> |

- Cut the packing strap securing the column support to the pallet.

| CAUTION | |
|---|--|
|  | <p>The column and column support are under spring tension from the counterbalance spring. Do NOT attempt to disassemble the column from the stand, but always keep the column support clamped together. When making height adjustments, carefully and slowly release the clamps to control the motion, and hold the stand to prevent sudden movements or injury.</p> |

- Remove the block(s) of wood between the base and the support by slowly loosening the two column clamps (allowing the stand to rise slightly) and then cutting the shipping tape on the block of wood. **RETIGHTEN THE COLUMN CLAMPS.**
- Loosen the two hub bolts (for column clamping) on the hub.
- Lift the actuator and column from the pallet. Carefully lay the stand on its right side (**NOT ON THE SIDE WITH THE LINEAR ENCODER**).
- Remove the hub from the pallet and set it aside. Some hubs are bolted to the pallet from the top.
- Unpack the converter, booster, cables, manuals, and toolkit that may be in the insert box. Save the packing material, including the blocks of wood.
- Go to Take Inventory of Small Parts. See [Table 4.1](#).

4.2.5 Actuator (alone)

The actuator, if shipped alone, is assembled and ready to install.

Move the shipping container close to the intended installation location, leave it on the floor.

- Open the top of the cardboard box, remove the insert from the top of the box and set it aside.
- The toolkit, mounting bolts, converter and/or booster, manuals and cables as ordered, are shipped with the actuator, located in their designated pockets in the foam packing material. Unpack the converter, booster, toolkit and bolts from their packages.
- Save the packing material.

| NOTICE | |
|---|--|
|  | The packaging may also include the converter and/or booster, if ordered. |

Figure 4.4 Ultrasonic Converter (J-Type for stand use) and Booster



4.3 Take Inventory of Small Parts

Table 4.1 Small Parts Included (=x) with Power Supply and/or Actuator Assemblies

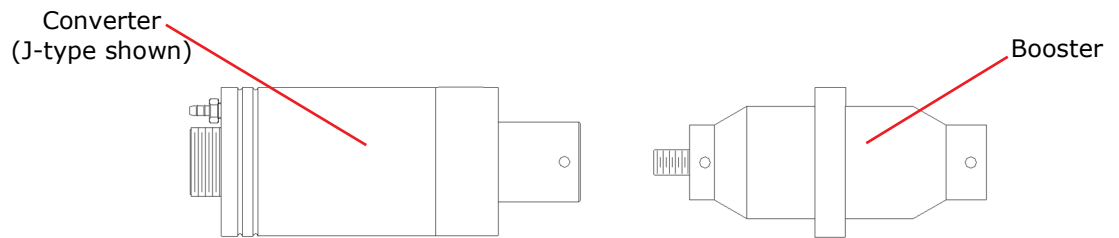
| Part or Kit | 2000X Power Supply | | | | Actuator | | |
|--------------------------|--------------------|--------|--------|--------|-----------------|-----------------|-----------------|
| | 15 kHz | 20 kHz | 30 kHz | 40 kHz | Stand (Base) | Stand (Hub) | (alone) |
| T-Handle Wrench | x | | | | x | x | x |
| Mylar Washer Kit | x | x | x | | | | |
| Silicone Grease | | | | x | | | |
| Actuator Mtg. Bolts | | | | | | | x |
| 20 kHz Spanners (2) | | x | | | | | |
| 30 kHz Spanners (2) | | | x | | | | |
| 40 kHz Spanners (2) | | | | x | | | |
| 40 kHz Sleeve | | | | | ordered part | ordered part | ordered part |
| 40 kHz Sleeve Spanner | | | | | ships w/ Sleeve | ships w/ Sleeve | ships w/ Sleeve |
| Fixture Bolts and Washer | | | | | x | | |
| M8 Allen Wrench | | | | | x | | |
| 5/64 Allen Wrench | | | | | | | |

4.3.1 Cables

Two cables connect the power supply and actuator: the actuator interface cable, and the RF cable. If the system is to be automated, you may also need a J911 start cable and a user I/O cable. Check your invoice for cable types and cable lengths.

Table 4.2 List of Cables

| Part Number | Description |
|-------------|--|
| 101-241-202 | Remote Pneumatic (RP) Package Cable (J924), 8' |
| 101-241-203 | Actuator Interface, 8' (J925S) |
| 101-241-204 | Actuator Interface, 15' (J925S) |
| 101-241-205 | Actuator Interface, 25' (J925S) |
| 101-241-206 | Actuator Interface, 50' (J925S) |
| 101-241-207 | Alarm I/O, 8' (J957S) |
| 101-241-208 | Alarm I/O, 15' (J957S) |
| 101-241-209 | Alarm I/O, 25' (J957S) |

Table 4.2 List of Cables

| Part Number | Description |
|-------------|--|
| 101-241-258 | Alarm I/O, 50' (J957S) |
| 101-240-020 | Start Cable (J911) 8' (req PLA) |
| 101-240-015 | Start Cable (J911) 15' (req PLA) |
| 101-240-010 | Start Cable (J911) 25' (req PLA) |
| 101-240-168 | Start Cable (J911) 50' (req PLA) |
| 101-240-072 | Start Cable (J913) 25' (no PLA req) |
| 101-240-017 | RF, 8' (J931S) |
| 101-240-012 | RF, 15' (J931S) |
| 101-240-007 | RF, 25' (J931S) Note: Not for 30 kHz or 40 kHz systems |
| 101-240-200 | RF, 50' (J931) Note: Not for 30 kHz or 40 kHz systems |
| 101-240-034 | RF, 8' (J934) |
| 101-240-035 | RF, 15' (J934) |
| 101-240-081 | RF, 8' (J936S) |
| 101-240-069 | RF, 15' (J936S) |
| 101-240-080 | RF, 25' (J936S) |
| 101-240-176 | RF, EN - 8' (J931CS) |
| 101-240-177 | RF, EN - 15' (J931CS) |
| 101-240-178 | RF, EN - 25' (J931CS) Note: Not for 30 kHz or 40 kHz systems |
| 101-240-297 | CBL EXT 36' RF J931C EN |
| 101-240-199 | RF, EN - 50' (J931C) |
| 101-240-179 | RF, EN - 8' (J934C) |
| 101-240-181 | RF, EN - 15' (J934C) |
| 159-240-182 | RF, EN - 20' (J934C) |
| 100-246-630 | Ground Detect Cable |

4.4 Installation Requirements

This section covers the location options, dimensions of the major assemblies, environmental requirements, electrical requirements and factory air requirements, to help you plan and execute your installation successfully.

4.4.1 Location

The actuator or stand may be installed in a variety of positions. The stand (on a base) is often manually operated, using its base-mounted start switches, and so is installed at a safe and comfortable workbench height (approximately 30-36 inches) with the operator sitting or standing in front of the system. Stands (on hubs) are often used in automated systems and may be manually or automatically loaded and unloaded. Actuators alone can be mounted in any orientation. Contact Branson if mounting upside down.

| WARNING | |
|---|--|
|  | The stand may tip over if moved around the axis of its column, if not properly secured. The work surface on which a stand is installed must be sturdy enough to support it, and secure enough to not tip over when the stand is adjusted during installation or setup. |

The power supply may be located up to 25 feet away for the 15 kHz, (50' for 20 kHz, 20' for 30 kHz, and 15' for 40 kHz models) from the actuator. The power supply must be accessible for user parameter changes and settings, and must be placed in a horizontal orientation. The power supply should be positioned so it does not draw in dust, dirt or material via its rear fans. Refer to the illustrations on the pages that follow for a dimensional drawing of each component. All dimensions are approximate and may vary between models:

[Figure 4.5 aed Actuator Dimensional Drawing.](#)

[Figure 4.6 Power Supply Dimensional Drawing.](#)

[Figure 4.7 Base Mounting Centers.](#)

[Figure 4.8 Mounting Bolt Pattern for the Hub \(for Stand on Hub\).](#)

Figure 4.5 aed Actuator Dimensional Drawing

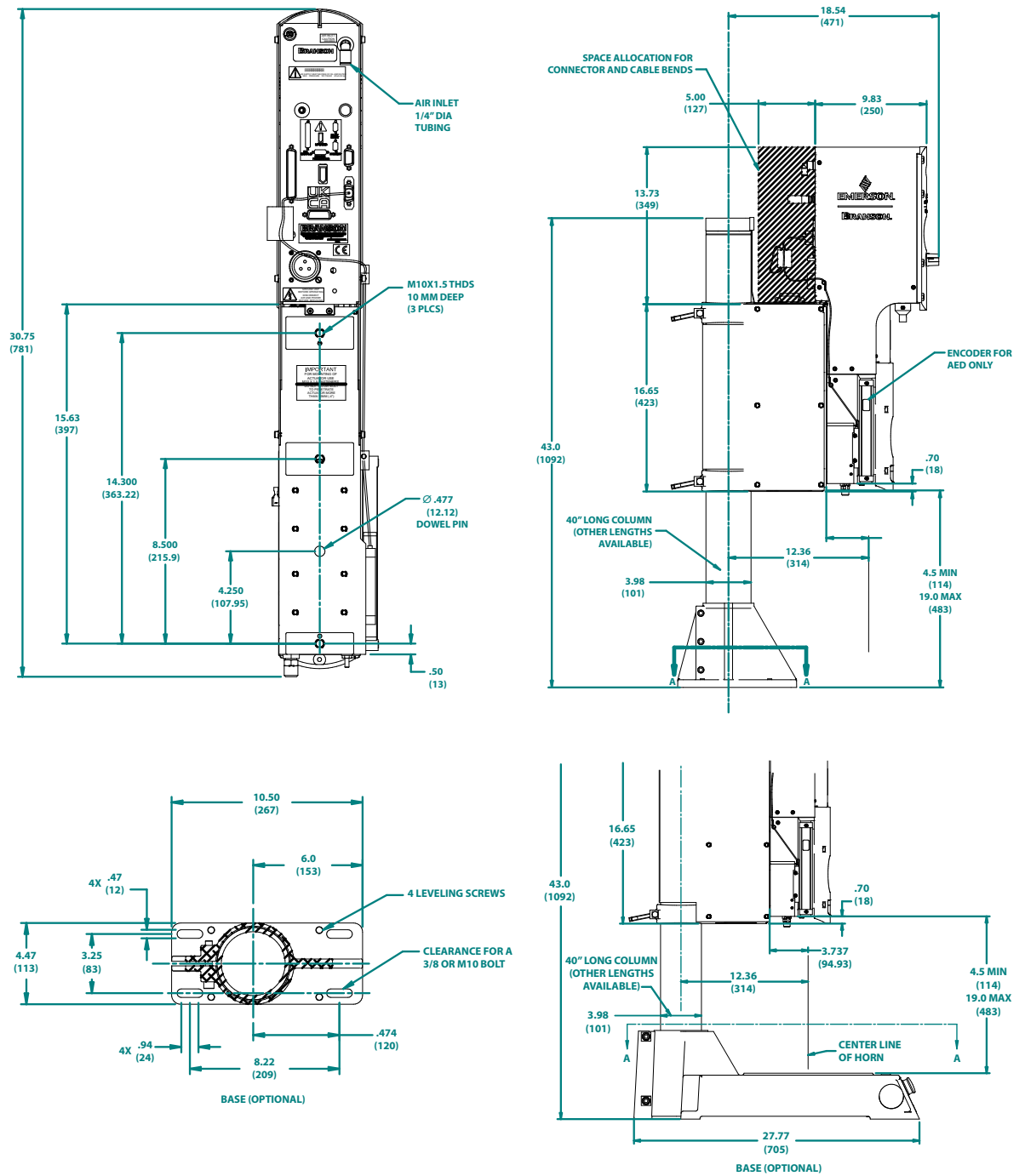

| HORN DIMENSIONS | FREQUENCY | | | DIMENSION SHOWN ARE APPROXIMATE TO ALLOW FOR DIFFERENT BOOSTER GAIN HORN DESIGN, MATERIAL AND TUNING. ALL HORN DIMENSIONS ARE FOR 1/2 WAVE DESIGNS. ALLOW FOR ADJUSTABILITY AND POTENTIAL TOOLING CHANGE. |
|---|--------------|--------------|--------------|---|
| | 20 KHz | 30 KHz | 40 KHz | |
|  HORN WIDTH AND LENGTH WILL VARY WITH EACH DESIGN | 2.12 TO 2.75 | 1.30 TO 1.54 | 0.69 TO 0.94 | |
| | 5 TO 5.50 | 2.97 TO 3.80 | 2.5 TO 2.75 | |

Figure 4.6 Power Supply Dimensional Drawing



4.4.2 Environmental Specifications

Table 4.3 Environmental Specifications

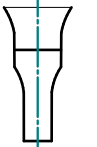
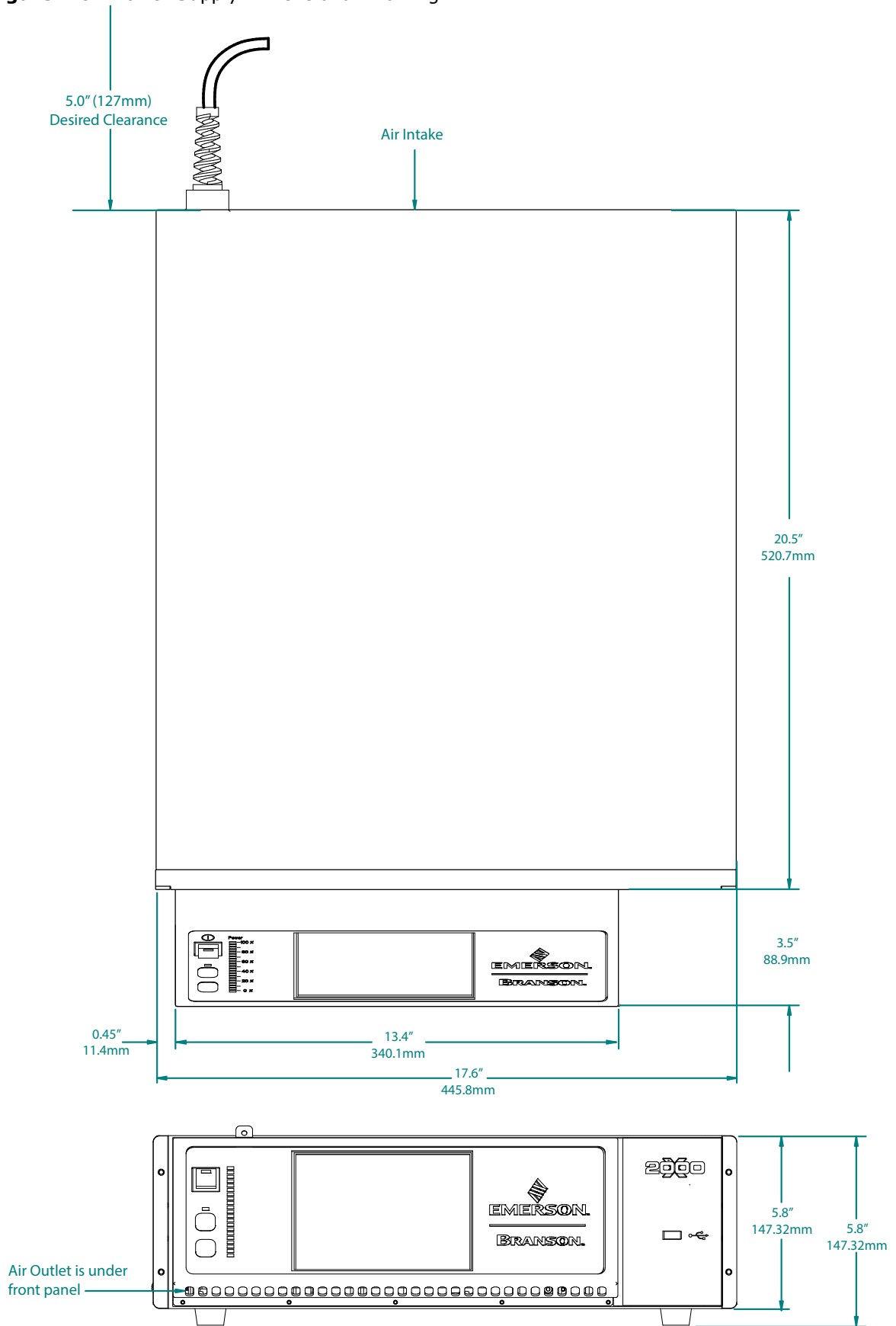
| Environmental Concern | Acceptable Range |
|--------------------------------|--|
| Humidity | 30% to 95%*, non-condensing |
| Ambient Operating Temperature | +5°C to +50°C (41°F to 122°F) |
| Storage / Shipping Temperature | -25°C to +55°C (-13°F to +131°F); Up to +70°C (+158°F) for 24 hours |

*Above 40°C the humidity drops to 90%

4.4.3 Electrical Input Power Ratings

Plug the Power Supply into a single-phase, grounded, 3-wire, 50 or 60 Hz power source. [Table 4.4](#) lists the current and fuse ratings for the various models.

Table 4.4 Input Power Requirements

| Model | Power | Current Rating | NEMA Connector |
|-------------------|--------------------|----------------------------------|------------------|
| For 15 kHz models | 3300 W 200V - 240V | 21 Amp Max. @ 200V / 25 Amp fuse | * |
| For 20 kHz models | 1250 W 200V - 240V | 7 Amp Max. @ 200V / 20 Amp fuse | NEMA L6-20P Plug |
| | 1250 W 100V - 120V | 14 Amp Max. @ 100V / 20 Amp fuse | NEMA 5-15P Plug |
| | 2500 W 200V - 240V | 14 Amp Max. @ 200V / 20 Amp fuse | NEMA L6-20P Plug |
| | 4000 W 220V - 240V | 25 Amp Max. @ 220V / 25 Amp fuse | * |
| For 30 kHz models | 750 W 100V - 120V | 10 Amp Max. @ 100V / 20 Amp fuse | NEMA 5-20P Plug |
| | 750 W 200V - 240V | 5 Amp Max. @ 200V / 20 Amp fuse | NEMA L6-20P Plug |
| | 1500 W 200V - 240V | 10 Amp Max. @ 200V / 20 Amp fuse | NEMA L6-20P Plug |
| For 40 kHz models | 400 W 200V - 240V | 3 Amp Max. @ 200V / 20 Amp fuse | NEMA L6-20P Plug |
| | 400 W 100V - 120V | 5 Amp Max. @ 100V / 20 Amp fuse | NEMA 5-15P Plug |
| | 800 W 200V - 240V | 5 Amp Max. @ 200V / 20 Amp fuse | NEMA L6-20P Plug |
| | 800 W 100V - 120V | 10 Amp Max. @ 100V / 20 Amp fuse | NEMA 5-15P Plug |

* To be hardwired by customer.

4.4.4 Factory Air

The factory compressed air supply must be “clean (to a 5 micron level), dry and unlubricated” air with a regulated maximum pressure of 100 psig (690 kPa). Depending on your application, the actuator requires between 35 to 100 psi. Stands include an in-line air filter. Actuators (alone) require a customer-provided air filter. A quick-disconnect fitting is suggested. Use a lockout device on the air line if required.

| WARNING | |
|---|--|
|  | Synthetic air compressor lubricants containing Silicone or WD-40 will cause internal actuator damage and failure due to the solvents contained within these types of lubricants. |

4.4.4.1 Air Filter

Actuators (alone) require a customer-provided air filter which protects from particulate matter of 5 microns or larger. If a stand is mounted in a position other than upright (vertical), its air filter must be relocated and oriented so its bowl is the lowest point, and the air flow across the air filter is horizontal. This may require some re-plumbing of the existing equipment at the customer site. The air filter is held in place by two screws on a bracket bolted to the column support, and by the factory-installed tubing. For further information, see your Actuator manual.

4.4.4.2 Pneumatic Tubing and Connectors

Actuator assemblies are not externally plumbed from the factory, but provide conventional 1/4-inch OD pneumatic tubing connection at the air inlet. If making connections for an actuator, or if re-plumbing your system for a new air filter location, you must use 1/4-inch OD tubing and connectors rated above 100 psi (use “Imperial Eastman Poly-Flo Tubing 44-P-1/4” or equivalent, and appropriate connectors). Refer to Actuator manual.

4.4.4.3 Pneumatic Connections to Actuator

Air connection to the actuator is made to the AIR INLET connector on the top rear of the actuator, with plastic pneumatic tubing. For installations using actuator-alone assemblies, you must provide an air filter assembly which will support at least to 100 psig and remove particulate matter of 5 microns or larger.

4.5 Installation Steps

| WARNING | |
|---|---|
|  | <p>This product is heavy and can cause a pinching or crushing injury during installation or adjustment. Keep clear of moving parts and do not loosen clamps unless directed to do so.</p> |

| CAUTION | |
|---|--|
|  | <p>If a stand is not mounted in a vertical position, the air filters (on the column support) must be removed, reoriented, and replumbed. Failure to do so can cause air filter failure, and actuator failures.</p> |

4.5.1 Mounting the Stand (Actuator on Base)

The base must be bolted to your workbench to prevent tipping or undesired movement. Four mounting bolt holes are provided at the corners of the casting, and will accept your 3/8 inch or M10 cap screws. Use flat washers against the metal casting to prevent gouging. Refer to [Figure 4.7 Base Mounting Centers](#).

| CAUTION | |
|---|--|
|  | <p>You must secure the base to your work surface using four bolts, to prevent tipping or undesired movement, in the event the actuator is moved off-center or rotated around the column.</p> |

1. Ensure there are no overhead obstructions and that no pinch or rub points exist. Remember that the actuator is taller than the column when fully raised, and there are exposed connections.
2. Mount the base to your workbench using four socket-head cap screws (customer provided, 3/8 inch (US bases) or M10 (metric bases)). Use flat washers against the metal casting to prevent gouging.
The use of nylon lock nuts with your cap screws is suggested, to reduce loosening due to vibration and movement.
3. Connect factory air to the air hose on the stand (3/8 NPT male fitting on the hose). A quick-disconnect fitting is suggested. Use a lockout device on the air line if required.
4. Verify the base/start switch control cable is properly connected to the back of actuator.
5. Verify the linear encoder connector is properly connected to the back of the actuator.

Figure 4.7 Base Mounting Centers

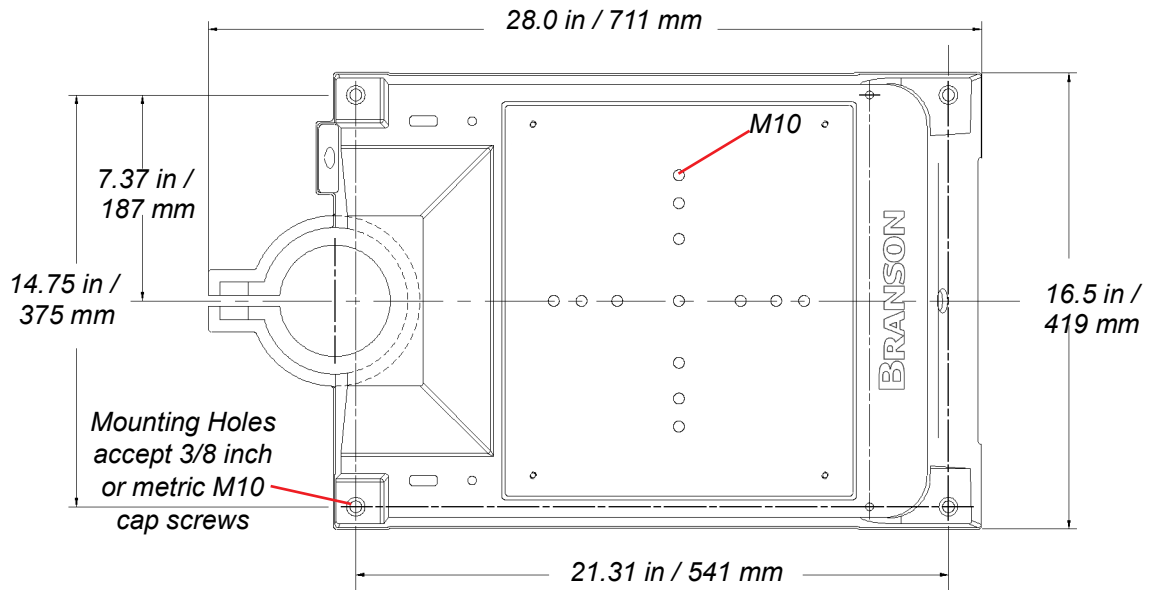

4.5.2 Mounting the Stand (Actuator on Hub-mounted column)

During unpacking, you removed the hub from the column/stand assembly. You must choose a mounting location for the hub that will support the column and actuator, and provide the hardware to mount it. Four mounting bolt holes are provided at the corners of the casting, and will accept your 3/8 inch or M10 hardware.

Use flat washers against the metal casting to prevent gouging. Refer to [Figure 4.8 Mounting Bolt Pattern for the Hub \(for Stand on Hub\)](#).



| CAUTION | |
|---|---|
|  | <p>The hub must be installed with its front in the same direction as the front of the actuator. The column bolts of the hub are found on the rear of the hub. See Figure 4.8 Mounting Bolt Pattern for the Hub (for Stand on Hub) for mounting details.</p> |

Figure 4.8 Mounting Bolt Pattern for the Hub (for Stand on Hub)

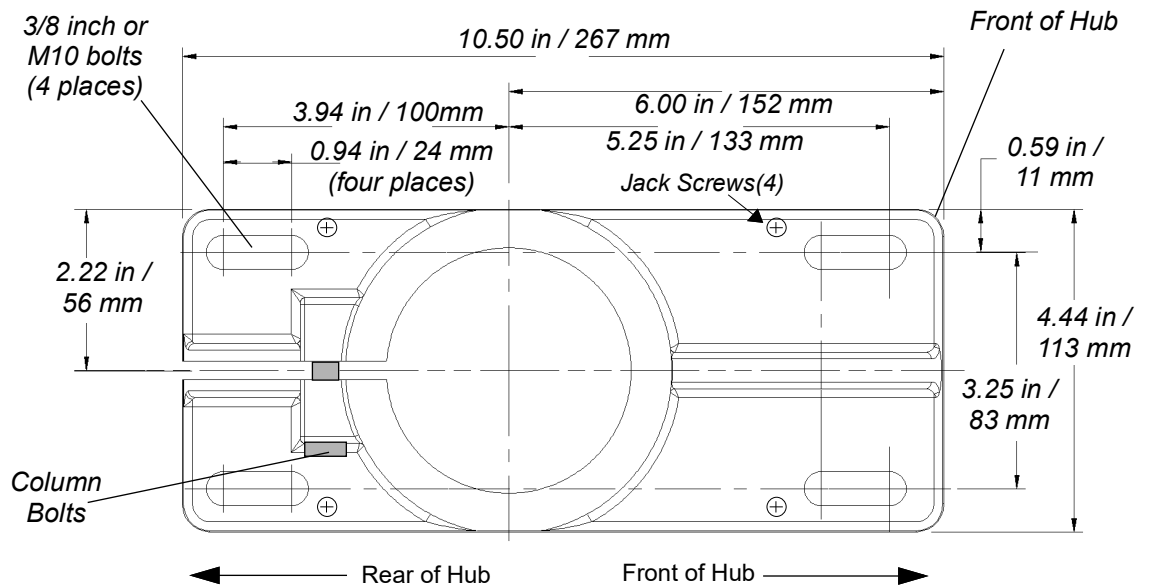

1. Locate the hub in the desired location. Ensure no overhead or side obstructions will interfere with normal operation or use of the system.

| CAUTION | |
|---|---|
|  | <p>Mount the hub to your work surface using four bolts, 3/8-inch or M10 shank size, with flat washers against its metal casting (customer provided hardware).</p> |

2. Carefully lift the actuator and column assembly, and mount the column in the hub. Align the flat face of the spring swivel with the top-front of the actuator. Tighten the two bolts on the hub.
3. Connect factory air to the air hose on the stand (3/8 NPT male fitting on the hose). A quick-disconnect fitting is suggested. Use a lockout device on the air line if required.
4. Verify the base/start switch control cable is properly connected to the back of actuator.
5. Verify the linear encoder connector is properly connected to the back of the actuator.
6. Use jack screws to fine adjust the system level. A 3/16" allen wrench should be used for the 3/8"-16 x 3/4" jack screws.

4.5.3 Actuator (alone)

The actuator (alone) is intended for installation on your custom-made mounting support. It is located in place with a mounting pin and secured using three metric bolts which are provided with the actuator.

1. Lift the actuator from the box. Carefully lay the assembly on its right side (NOT on the side with the linear encoder).

| CAUTION | |
|---|--|
|  | The actuator support bolts for the 2000X-Series actuators are metric, M10 x 1.5 thread pitch, 25mm long. The support pin and mounting bolts must not extend more than 0.40 in (10 mm) into the actuator, otherwise, binding or damage to the carriage may occur. |

| CAUTION | |
|--|---|
|  | DO NOT use 900-Series M10 x 1.25 mounting bolts. They have a different thread pitch and will not interchange with those used on the 2000X-Series. |

2. Use of a guide pin is suggested. It is not provided with the actuator. If you require a guide pin, use a solid metal dowel pin, 12mm diameter, which must not extend into the actuator more than 0.40 inch (10mm) from your support.

Figure 4.9 Actuator Rear View, Mounting Surface, Bolt and Guide Pin Locations

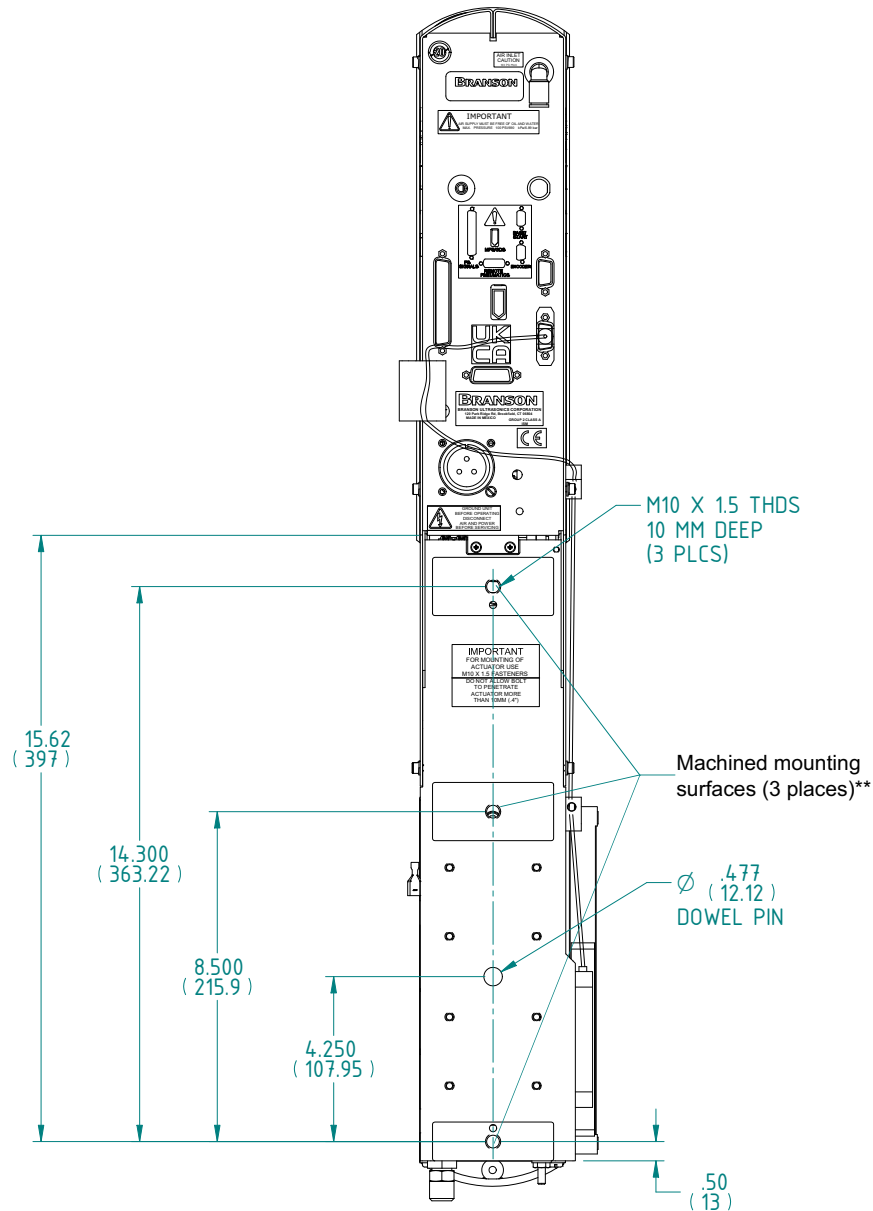

Rear view of ae/aed actuator is shown. Although other actuators will vary in height, referenced dimensions will be the same for all models.

**These three mounting surfaces are flat within 0.004 in. (0.1mm) TIR, in a tolerance zone of 16 x 3.5 in. (410 x 90 mm). The surface to which the actuator is mounted must also have the same flatness tolerance.

- Lift the actuator assembly into position on your mount, and secure using the metric bolts provided.

| CAUTION | |
|---|--|
|  | <p>In the event you must use bolts of a different length, ensure that the bolts extend more than 0.25 inch (6 mm) into the threads in the actuator housing, but less than 0.40 inch (10 mm).</p> |

4.5.4 Mount the Power Supply

The power supply is designed to be placed on a workbench (rubber feet on bottom) within cable-length limits of the actuator, or it may be rack-mounted in a standard 19-inch Rack (using an optional rack mount handle kit). It has two rear-mounted fans which draw cooling air from rear to front, which must be free from obstruction. Do not place the power supply on the floor or in other locations that will allow dust, dirt or contaminants to be drawn into the power supply.

The controls on the front of the power supply must be accessible and readable for setup changes.

All electrical connections are made to the rear of the power supply, which should be positioned in your workspace with adequate clearance (approximately 4 inches or more on either side, and 6 inches to the rear) for cable access and ventilation. Do not place anything on top of the power supply case.

See [Figure 4.6 Power Supply Dimensional Drawing](#) for a dimensional drawing of the 2000X Power Supply.

4.5.5 Interconnect between Power Supply and Actuator

Figure 4.10 Connections on Rear of Power Supply

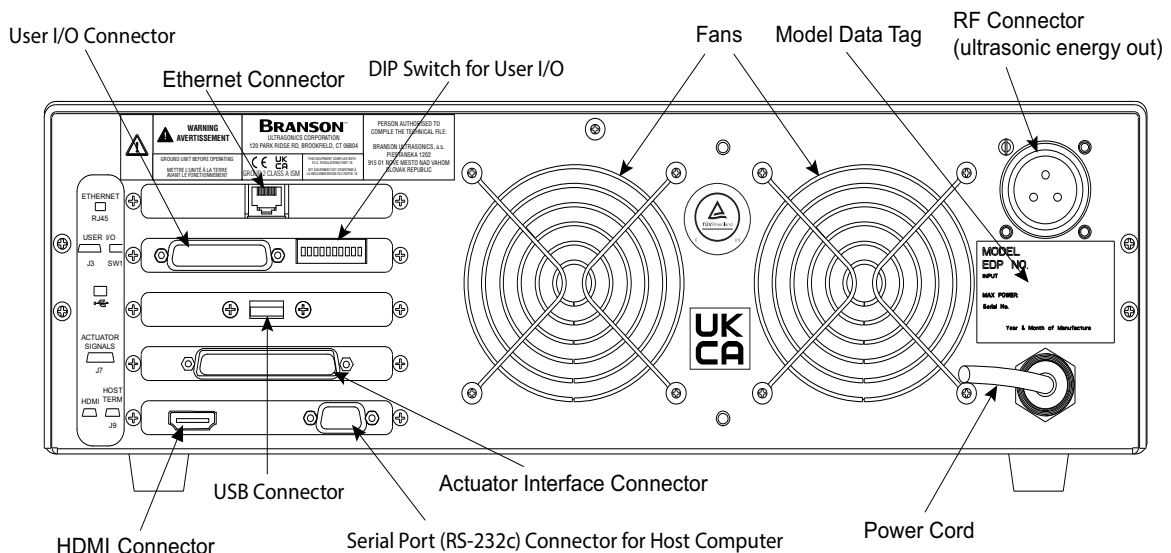

The cable lengths are limited because of the amount and type of power and control being delivered to the remainder of the system. Performance and results can suffer if the RF cable is crushed, pinched, damaged or modified. Contact your Branson Representative if you have special cable requirements. In some cases, remote operation from a User I/O or a Remote Computer can be used to solve a distance limitation.

4.5.6 Input Power (Main)

The system requires single-phase input power, which you connect to the Power Supply using the integral power cord. See [Table 4.4](#) for plug and receptacle requirements for your specific power level.

Refer to the unit's Model Data Tag to be sure of the power rating of the Model in your system.

4.5.7 Output Power (RF Cable)

Ultrasonic Energy is delivered to a screw-on receptacle connection on the rear of the Power Supply, which is connected to the Actuator or the Converter (depending on your application).

| WARNING | |
|---|---|
|  | <p>Never operate the System with the RF Cable disconnected or if the RF Cable is damaged.</p> |

4.5.8 Interconnect between Power Supply and Actuator

If using a Branson 2000X-series Actuator, there are two electrical connections between the Power Supply and the Actuator: the RF Cable and the Actuator Interface cable. A 37-pin cable is used for Power and Control Signaling between the 2000X Power Supply and a Branson Actuator. The cable connects to the rear of the Power Supply and the rear of the Actuator. Refer to [Figure 4.10](#) for clarification of connections on rear of power supply.

There can be other connections to the Actuator, and other connections to the Power Supply, but these are the only two standard connections, depicted in [Figure 4.11](#).

For ground detect use, to have ultrasonic energy turn off when the horn comes in contact with your electrically isolated fixture or anvil, it is necessary to install Branson cable EDP No. 100-246-630 from the MPS/GDS receptacle on the rear of the actuator to your isolated fixture/anvil in order to utilize this feature.

Figure 4.11 Electrical Connections from Power Supply to a 2000X-series Actuator

*ae/aed actuator air input shown
**aed and aef only

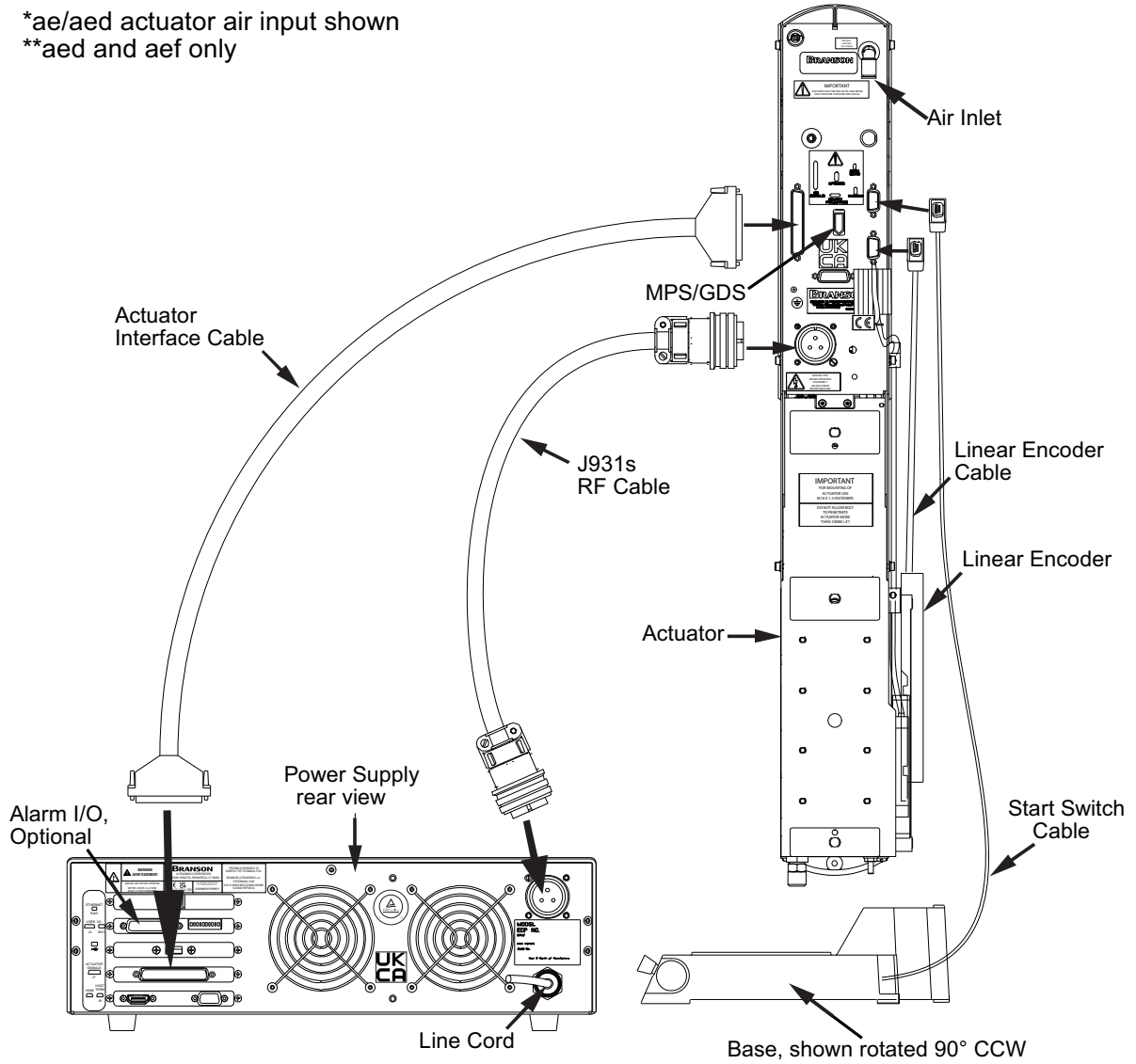

4.6 Start Switch Connection (Automation)

| NOTICE | |
|---|--|
|  | <p>See Appendix A: Automation for additional information about Automation.</p> |

A Branson actuator requires 2 start switches and emergency stop connection. Stands on a base include this connection (factory installed and connected from the base) while the stand on a hub and actuator (alone) applications require the user make their own start switch/E-stop connections, as follows:

| NOTICE | |
|--|---|
|  | <p>Refer to actuator data tag to determine if actuator is CE.</p> |

Figure 4.12 Start Switch Connection Codes (Non-CE Actuator)



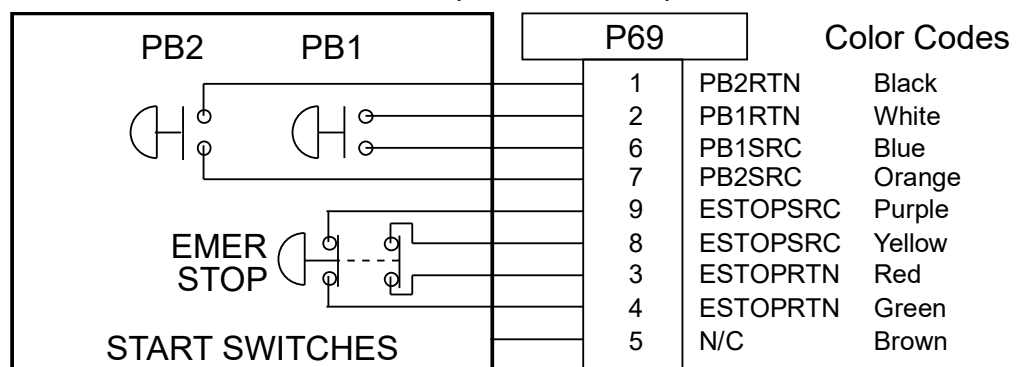
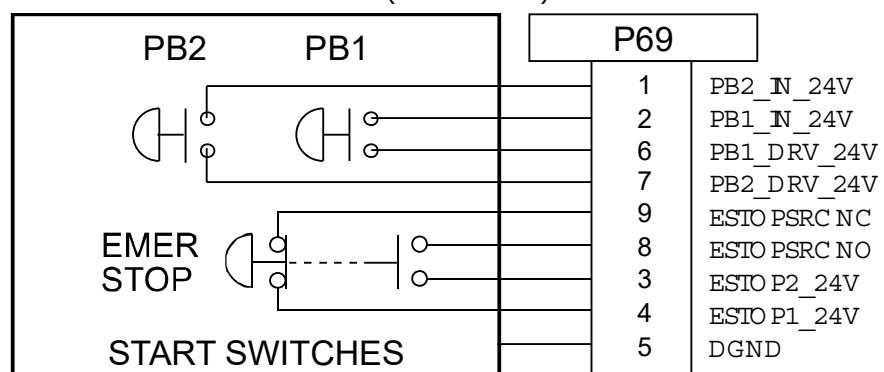

EMER STOP is an emergency stop switch, with both switches normally closed.

Figure 4.13 Start Switch Connection Codes (CE Actuator)



EMER STOP is an emergency stop switch with two contacts: one normally closed, and one normally open.

| NOTICE | |
|---|---|
|  | Solid state devices may be used in lieu of mechanical start switches providing their leakage current does not exceed 0.1mA. |

| NOTICE | |
|---|--|
|  | Start Switches PB1 and PB2 must be closed within 200 milliseconds of each other, and remain closed until the PB Release signal is active, to effect a start condition. |

BASE/START is the DB-9 female connection on the back of the actuator. Your cable requires a male DB-9 (D-shell) connector.

PB1 and PB2 are two normally open start-switches which must be operated simultaneously to start the welding cycle. These must be closed within 200 milliseconds of each other, or error message: "Start Sw Time" will display. This doesn't require a reset, but for the next cycle, switches must be within time limit to preclude re-occurrence of error message. Refer to Note above.

4.6.1 Serial (RS-232c) Port Connector

An RS-232c serial port (DB-9 format) is provided for the Host Computer option. Only three data leads of this port are supported at this time (Data Send TXD, Data Receive RXD, and Signal Ground GND). The remainder of the leads are 'reserved'. A null modem cable is required.

The comport parameters are fixed, can not be altered or viewed in the menu.

The fixed values are:

1. com speed = 9600 baud
2. no parity
3. 1 stop bit
4. 8 data bits

4.6.2 User I/O Interface

The user I/O is a standard interface for automation, provided on the power supply. It provides the ability for the customer to make their own interface for their automation or special control or reporting needs. The interface cable has an HD44 female D-shell connection on the rear of the power supply. The electrical interface outputs may be configured for open collector mode or for signal mode (signal voltage levels as indicated), by setting the user I/O DIP switch.

DIP switch SW1 for the user I/O is located next to the J3 on the back of the 2000X-series power supply.

User I/O interface cable pinout is listed in [Table 4.5 User I/O Cable Pin Assignments, Alphabetical Order](#).

Figure 4.14 User I/O Cable Identification and Wire Color Diagram

User I/O Cable
Stripped and tinned one end,
HD-44 male connector other end
(cable length as ordered)

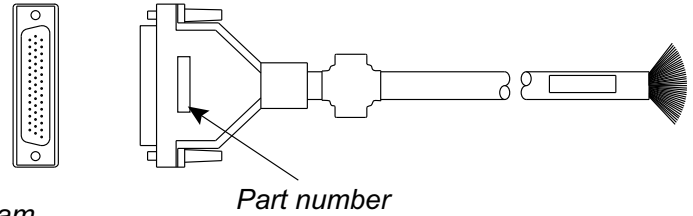

Wire Color Diagram
Two Colors = Insulator/Stripe
Three Colors = Insulator/Stripe/Dot

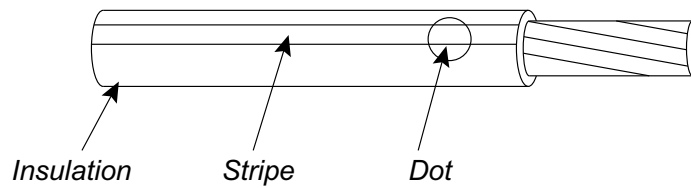

Table 4.5 User I/O Cable Pin Assignments, Alphabetical Order

| Pin | Signal Name | Signal Type | Direction | Signal Range | Definition | Colors |
|-----|-------------------|---------------|-----------|--------------|---|-------------|
| 7 | ACT_CLEAR | 0V True | Output | 0/24V, 100mA | Actuator clear signal | Red/Wht |
| 24 | AMPLITUDE_OUT | Analog | Output | 0V to 10V | Amplitude signal from PS | Red/Blk/Grn |
| 2 | CYCLE_ABORT | 24V True | Input | 0/24V, 100mA | | Red/Blk |
| 3 | EXT_RESET | 24V True | Input | 0/24V, 100mA | System Reset | Grn/Blk |
| 18 | EXT_SEEK+ | 24V True | Input | 0/24V, 100mA | | Red/Blk/Wht |
| 38 | FREQ_OUT | Analog | Output | -10V to +10V | Frequency Signal from PS | Blk/Wht/Blu |
| 6 | G_ALARM | 0V True | Output | 0/24V, 100mA | | Blk/Wht |
| 14 | GEN_ALARM_RELAY_1 | Relay Contact | Output | 40V, 0.25A | Contact Closure | Red/Grn |
| 29 | GEN_ALARM_RELAY_2 | Relay Contact | Output | 40V, 0.25A | Contact Closure | Wht/Red/Orn |
| 1 | J3_1_INPUT | 24V True | Input | 0/24V, 100mA | User definable inputs. Refer to Table 4.6 to view available selections. | Wht/Blk |
| 17 | J3_17_INPUT | 24V True | Input | 0/24V, 100mA | | Wht/Blk/Red |
| 19 | J3_19_INPUT | 24V True | Input | 0/24V, 100mA | | Grn/Blk/Wht |
| 31 | J3_31_INPUT | 24V True | Input | 0/24V, 100mA | | Wht/Red/Blu |
| 32 | J3_32_INPUT | 24V True | Input | 0/24V, 100mA | | Blk/Wht/Grn |

Table 4.5 User I/O Cable Pin Assignments, Alphabetical Order

| Pin | Signal Name | Signal Type | Direction | Signal Range | Definition | Colors |
|-----|-------------------|----------------|-----------|---------------|--|-------------|
| 33 | J3_33_INPUT | 24V True | Input | 0/24V, 100mA | | Wht/Blk/Grn |
| 8 | J3_8_OUTPUT | 24V True | Output | 0/24V, 100mA | User definable outputs. Refer to Table 4.6 to view available selections. | Grn/Wht |
| 22 | J3_22_OUTPUT | 24V True | Output | 0/24V, 100mA | | Blk/Red/Grn |
| 36 | J3_36_OUTPUT | 24V True | Output | 0/24V, 100mA | | Orn/Red/Grn |
| 9 | MEM | Analog | Output | -10V to +10V | Memory Signal from PS | Blu/Wht |
| 11 | MEM_CLEAR | Open Collector | Output | 24V, 25mA max | Memory Clear signal send to PS | Wht/Red |
| 40 | MEMORY_STORE | Open Collector | Output | 24V, 25mA max | Memory store from PS | Red/Wht/Blu |
| 34 | PB_RELEASE | 0V True | Output | 0/24V, 100mA | | Red/Wht/Grn |
| 37 | PWR | Analog | Output | 0V to 10V | Power Signal from PS | Blu/Red/Grn |
| 21 | READY | 0V True | Output | 0/24V, 100mA | | Blu/Blk/Wht |
| 5 | REJECT | 0V True | Output | 0/24V, 100mA | | Blu/Blk |
| 43 | READY_RELAY_1 | Relay Contact | Output | 40V, 0.25A | Contact Closure | Blu/Orn/Red |
| 15 | READY_RELAY_2 | Relay Contact | Output | 40V, 0.25A | Contact Closure | Orn/Grn |
| 26 | RUN | Open Collector | Output | 24V, 25mA max | Run signal send to PS | Orn/Blk/Grn |
| 39 | SEEK | Open Collector | Output | 24V, 25mA max | Seek Signal send to PS | Wht/Blk/Blu |
| 4 | SOL_VALVE_SRC | 24V | Output | 0/24V, 125mA | SV1 Source | Orn/Blk |
| 16 | SOL_VALVE_RTN | 24V Return | Input | 0V | SV1 Return | Blk/Wht/Red |
| 20 | SUSPECT_PART | 0V True | Output | 0/24V, 100mA | | Orn/Blk/Wht |
| 10 | USER_AMP_IN | Analog | Input | -10V to +10V | User Amplitude control signal | Blk/Red |
| 25 | USER_FREQ_OFF SET | Analog | Input | -10V to +10V | User Freq. offset control signal | Grn/Blk/Orn |
| 35 | WELD_ON | 0V True | Output | 0/24V, 100mA | Start of sonics and trigger | Grn/Wht/Blu |
| 30 | WELD_ON_RELAY_1 | Relay Contact | Output | 40V, 0.25A | Contact Closure | Orn/Wht/Blu |
| 44 | WELD_ON_RELAY_2 | Relay Contact | Output | 40V, 0.25A | Contact Closure | Blk/Orn/Red |
| 23 | +10V_REF | Analog | Output | 10.0V | 10VDC ref. voltage from PS | Wht/Red/Grn |

Table 4.5 User I/O Cable Pin Assignments, Alphabetical Order

| Pin | Signal Name | Signal Type | Direction | Signal Range | Definition | Colors |
|-----|-------------|-------------|-----------|----------------|------------|-------------|
| 12 | 24V_RTN | 24V Ground | Input | 0V | 24V Return | Orn/Red |
| 13 | 24V_SRC | 24V Source | Output | 24V, 1.25A max | 24V Source | Blu/Red |
| 27 | 24V_RTN | 24V Ground | Input | 0V | 24V Return | Blu/Wht/Orn |
| 28 | 24V_SRC | 24V Source | Output | 24V, 1.25A max | 24V Source | Blk/Wht/Orn |
| 41 | 24V_RTN | 24V Ground | Input | 0V | 24V Return | Grn/Orn/Red |
| 42 | 24V_SRC | 24V Source | Output | 24V, 1.25A max | 24V Source | Orn/Red/Blu |

CAUTION



Ensure all unused wires are properly isolated. Failure to do so may result in Power Supply or system failure.

NOTICE



Refer to the Branson Automation Guide (EDP [100-214-273](#)) for additional information about selection and use of Input and Output features listed in the following Table.

Table 4.6 User I/O Input and Output Function Selection

| Input | | Output | |
|-------------|--|--------------|----------------|
| J3_1_INPUT | Disabled Ext U/S Delay Display Lock Sonics Disable Memory Reset External Start Ext Signal Sync In | J3_8_OUTPUT | Disabled |
| J3_17_INPUT | | J3_22_OUTPUT | Confirm Preset |
| J3_19_INPUT | | J3_36_OUTPUT | Ext Beeper |
| J3_31_INPUT | | | Cycle Okay |
| J3_32_INPUT | | | No Cycle Alarm |
| J3_33_INPUT | | | Overload Alarm |
| | | | Modified Alarm |
| | | | Note |
| | | | Missing Part |
| | | | External Start |
| | | | Sync Out |

4.6.3 Input Power Plug

If you must add or change the input power plug, use the following color code for the conductors found in the international harmonized line cord. Add the plug that is appropriate for your input power receptacle.

| CAUTION | |
|---|--|
|  | The power supply can be permanently damaged if it is connected to the incorrect line voltage, or if the wiring connection is mis-wired. It also presents a safety hazard if mis-wired. Use of the correct plug or connector helps prevent incorrect connections. |

Figure 4.15 International Harmonized Line Cord Color Code



4.6.4 User I/O DIP Switch (SW1)

DIP switch SW1, for the user I/O is located next to the J3 on the back of the 2000X-series power supply, as shown in [Figure 4.10 Connections on Rear of Power Supply](#). The settings of these switches affect the user I/O signals. Factory default setting is for all dip switches is set to ON (closed: switch position closest to number designation).

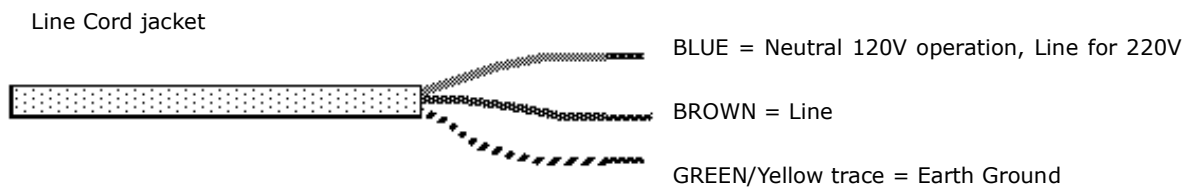
- If the dip switch is set to the ON (closed) position, the corresponding Output pin will be configured as the current source, 25mA max.
- If the dip switch is set to the OFF (open) position, the corresponding Output pin will be configured as an "open collector", 24VDC, 25 mA max. current sink.

Table 4.7 User I/O DIP Switch Functions

| Switch Position | Signal Description | Output Signal |
|-----------------|--------------------|---------------|
| 1 | REJECT_SIG | REJECT |
| 2 | SUSPECT_SIG | SUSPECT |
| 3 | PB_RELEASE_SIG | PB_RELEASE |
| 4 | G_ALARM_SIG | G_ALARM |
| 5 | READY_SIG | READY |
| 6 | WELD_ON_SIG | WELD_ON |
| 7 | ACTUATOR_CLEAR_SIG | ACT_CLEAR |
| 8 | J3_22_OUT_SIG | J3_22_OUTPUT |
| 9 | J3_36_OUT_SIG | J3_36_OUTPUT |
| 10 | J3_8_OUT_SIG | J3_8_OUTPUT |

4.7 Guards and Safety Equipment

4.7.1 Emergency Stop Control

If you use the Emergency Stop button on the Actuator to terminate a weld, twist the button to reset it. (The welder will not operate until this button is reset.) You must then press Reset at the power supply. If you are running automation, you can use external reset that is connected to your User I/O board.

Figure 4.16 Actuator Emergency Stop Button

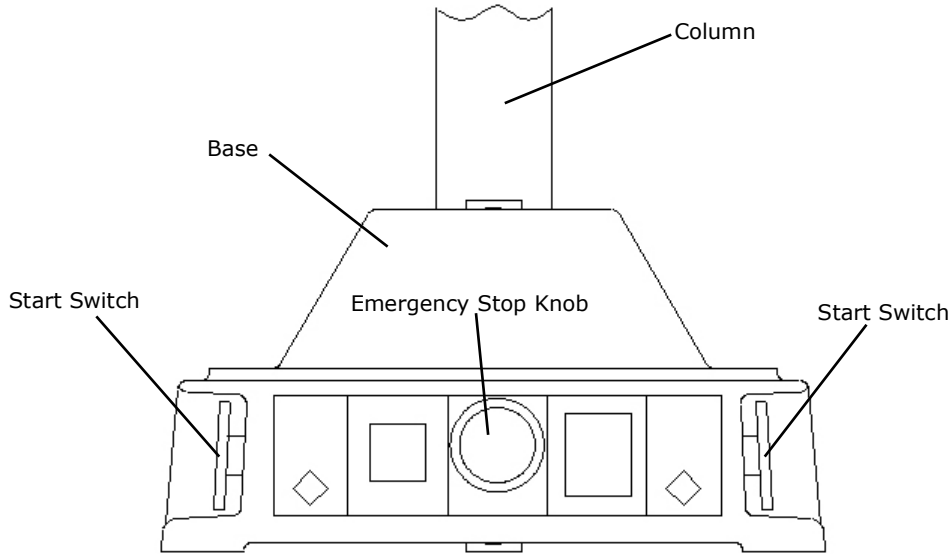

If you are using an Emergency Stop signal from the Start Switch cable, you must clear the Emergency Stop condition before the System will operate.

| WARNING | |
|---|---|
|  | <p>The Emergency Stop should be engaged prior to removing the door.</p> |

The 2000X Series control system has been designed to conform to the safety requirements of NFPA 79, EN 60204-1 and CFR 1910.212.

Two Hand Control of the 2000X Series control system has been designed to comply with Type 3 of NFPA, and Type III of EN 60204-1.

The Emergency Stop functions as a category 0 stop of both NFPA 79 and EN 60204-1.

4.8 Rack Mount Installation

If the system is Rack Mounted, you need to order the Rack Mount handle kit. The kit includes two rack mounting handles and two corner pieces, which support the handles and provide the rack mount interface.



| CAUTION | |
|---|---|
|  | <p>The Rack Mount handle kit does NOT support the power supply in the rack. The weight of the power supply must be supported by integral brackets of the rack itself.</p> |
| NOTICE | |
|  | <p>Do not permanently remove the Cover from the Power Supply because it is required for proper system cooling.</p> |

Figure 4.17 Detail of Rack Mount Handle Kit Assembly

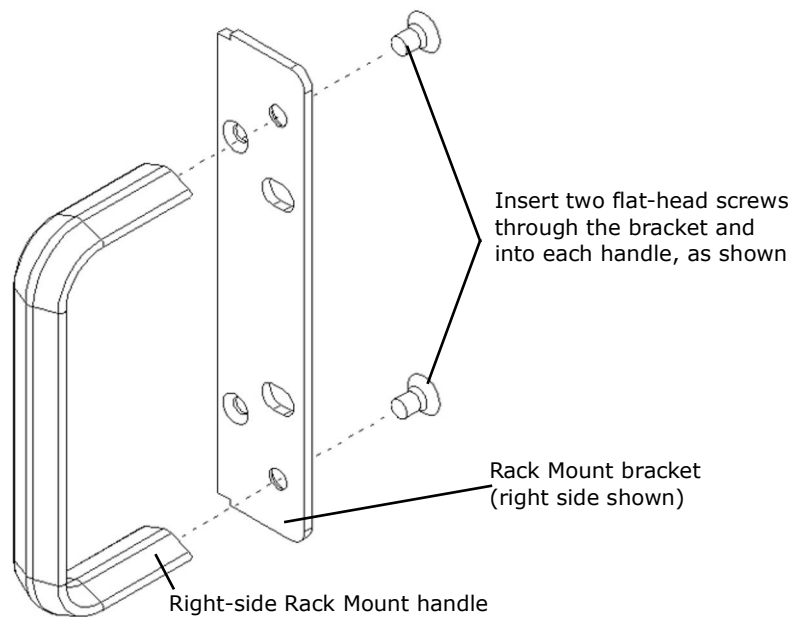



Table 4.8 Rack Mount Handle Kit Assembly

| Step | Procedure |
|------|---|
| 1 | Order and obtain the Rack Mount kit for your Power Supply. The brackets in the Kit are designed for standard 19-inch rack mounting options. |

Table 4.8 Rack Mount Handle Kit Assembly

| Step | Procedure |
|------|--|
| 2 | From the front corners of the Power Supply, remove the corner trim pieces by removing the two Phillips screws. Save the screws. |
| 3 | Noting that one side of each bracket is countersunk to accept the provided flathead screws, assemble the Rack Mount Handles as shown in Figure 4.17 Detail of Rack Mount Handle Kit Assembly . (This shows only the Right bracket and handle; the left side is a mirror-image.) Tighten the screws securely and so they are flush. |
| 4 | Re-using the screws you removed in Step 2, install the assembled Handle in place of the Front Corner pieces. |
| 5 | Save the removed hardware corner pieces. |
| 6 | When you are ready to install the unit, use the hardware from your Rack Mounting system to locate the Power Supply. |

4.9 Assemble the Acoustic Stack

| CAUTION | |
|---|---|
|  | <p>The following procedure must be performed by a setup person. If necessary, secure the largest portion of a square or rectangular horn in a soft jawed vise. NEVER attempt to assemble or remove a horn by holding the converter housing or the booster clamp ring in a vise.</p> |

| CAUTION | |
|---|--|
|  | <p>Do not use silicone grease with Mylar washers. Use only 1 (one) Mylar washer of the correct inside and outside diameters at each interface.</p> |

Table 4.9 Tools

| Tool | EDP Number |
|--------------------------------------|-------------|
| 15, 20, and 30 kHz Torque Wrench Kit | 101-063-787 |
| 40 kHz Torque Wrench | 101-063-618 |
| 15 kHz Spanner Wrench | 201-118-034 |
| 20 kHz Spanner Wrench | 101-118-039 |
| 30 kHz Spanner Wrench | 201-118-033 |
| 40 kHz Spanner Wrench | 201-118-024 |
| Silicone Grease | 101-053-002 |

4.9.1 For a 15 kHz and 20 kHz System

Table 4.10 Assembly for a 15 kHz and 20 kHz System

| Step | Action |
|------|---|
| 1 | Clean the mating surfaces of the converter, booster, and horn. Remove any foreign material from the threaded holes. |
| 2 | Install the threaded stud into the top of the booster. Torque to 450 in-lbs, 50.84 Nm. If the stud is dry, apply 1 or 2 drops of a light lubricating oil before installing. |

Table 4.10 Assembly for a 15 kHz and 20 kHz System

| Step | Action |
|------|---|
| 3 | Install the threaded stud into the top of the horn. Torque to 450 in-lbs, 50.84 Nm. If the stud is dry, apply 1 or 2 drops of a light lubricating oil before installing. |
| 4 | Install a single Mylar washer (matching the size of the washer to the stud) to each interface. |
| 5 | Assemble the converter to the booster and the booster to the horn. |
| 6 | Torque to 220 in-lbs, 24.85 Nm. (Torque 20 kHz and 15 kHz Solid Mount Converter to 250 in-lbs, 28.25 Nm.) |

4.9.2 For a 30 kHz System

Table 4.11 Assembly for a 30 kHz System

| Step | Action |
|------|---|
| 1 | Clean the mating surfaces of the converter, booster, and horn. Remove any foreign material from the threaded holes. |
| 2 | Apply a drop of Loctite®1 290 threadlocker (or equivalent) to the studs for the booster and horn. |
| 3 | Install the threaded stud into the top of the booster; torque to 290 in-lbs, 32.76 Nm, and let cure for 30 minutes. |
| 4 | Install the threaded stud into the top of the horn; torque to 290 in-lbs, 32.76 Nm, and let cure for 30 minutes. |
| 5 | Install a single Mylar washer (matching the size of the washer to the stud) to each interface. |
| 6 | Screw the converter onto the booster. |
| 7 | Torque to 185 in-lbs, 21 Nm. |
| 8 | Slide the booster/converter assembly into the adapter sleeve. Screw on the adapter sleeve ring nut and leave loose. |
| 9 | Screw the booster onto the horn. |
| 10 | Repeat Step 7. |
| 11 | Securely tighten the adapter sleeve ring nut with the spanner wrenches shipped with the sleeve assembly. |

Loctite is a registered trademark of Henkel Corporation, U.S.A.

4.9.3 For a 40 kHz System

Table 4.12 Assembly for a 40 kHz System

| Step | Action |
|------|---|
| 1 | Clean the mating surfaces of the converter, booster, and horn. Remove any foreign material from the threaded holes. |
| 2 | Apply a drop of Loctite 290 threadlocker (or equivalent) to the studs for the booster and horn. |
| 3 | Install the threaded stud into the top of the booster; torque to 70 in-lbs, 7.91 Nm, and let cure for 30 minutes. |
| 4 | Install the threaded stud into the top of the horn; torque to 70 in-lbs, 7.91 Nm, and let cure for 30 minutes. |
| 5 | Coat each interface surface with a thin film of silicon grease – but do not apply silicon grease to a threaded stud or tip. |
| 6 | Screw the converter to the booster. |
| 7 | Torque to 95 in-lbs, 10.73 Nm. |
| 8 | Slide the booster/converter assembly into the adapter sleeve. Screw on the adapter sleeve ring nut and leave loose. |
| 9 | Screw the booster onto the horn. |
| 10 | Repeat Step 7. |
| 11 | Securely tighten the adapter sleeve ring nut with the spanner wrenches shipped with the sleeve assembly. |

4.9.4 Assembling the Acoustic Stack (shown with rectangular horn secured in the vise)

Figure 4.18 Assembling the 20 kHz Acoustic Stack

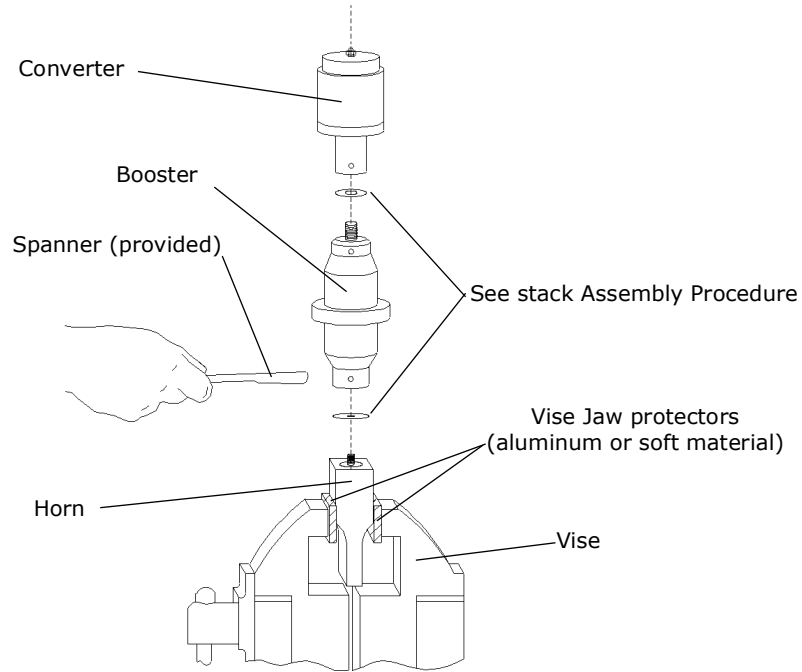

Stack Assembly Torque Tables

| NOTICE | |
|---|--|
|  | <p>The use of a Branson torque wrench or the equivalent is recommended. P/N 101-063-787 for 15, 20, and 30 kHz systems and 101-063-618 for 40 kHz systems.</p> |

Table 4.13 Stud Torque Values

| Used On | Stud Size | Torque | EDP # |
|-------------------|--------------------|------------------------|--------------|
| 15 kHz and 20 kHz | 1/2" x 20 x 1-1/2" | 450 in.-lbs, 50.84 Nm. | 100-098-123 |
| 20 kHz | 1/2" x 20 x 1-1/4" | 450 in.-lbs, 50.84 Nm. | 100-098-370 |
| 30 kHz* | 3/8" x 24 x 1" | 290 in.-lbs, 32.76 Nm. | 100-298-170R |
| 40 kHz* | M8 x 1.25 | 70 in.-lbs, 7.91 Nm. | 100-098-790 |

* Add a drop of Loctite 290 threadlocker to the stud. Torque and let cure for 30 minutes before use.

4.9.5 Connecting Tip to Horn

1. Clean the mating surfaces of the horn and tip. Remove foreign matter from the threaded stud and hole.
2. Hand assemble the tip to the horn. Assemble dry. Do not use any silicone grease.
3. Use the spanner wrench and an open-end wrench (Refer to [Figure 4.19 Connecting Tip to Horn](#)) and tighten to the following torque tip specifications:

Figure 4.19 Connecting Tip to Horn

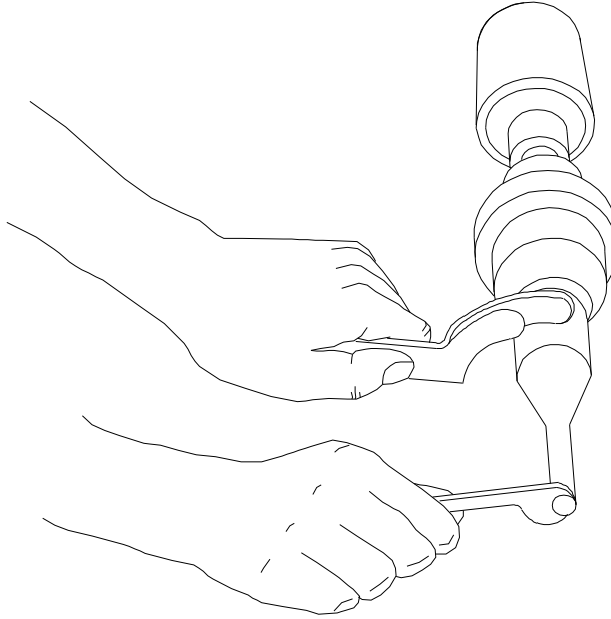

Table 4.14 Tip to Horn Torque Values

| Tip Thread | Torque |
|------------|------------------------|
| 1/4-28 | 110 in.-lbs, 12.42 Nm. |
| 3/8-24 | 180 in.-lbs, 20.33 Nm. |

4.10 Installing the Ultrasonic Stack in the Actuator

This section lists the steps and indicates the assembly procedures for various ultrasonic stacks.

4.10.1 15 kHz, 20 kHz, and 30 kHz Converter Stacks

The ultrasonic stack must first be assembled. To install the stack:

1. Make sure that the system power is turned off by disconnecting the power plug.
2. Engage the Emergency Stop.
3. Loosen the four door screws.
4. Pull the door straight off and set it aside.
5. Take the assembled ultrasonic stack and align the ring on the booster just above the support washer in the carriage. Firmly push the stack into place, with the acorn nut on the top of the converter making contact with the contactor in the top of the carriage.
6. Reinstall the door assembly, and start the four door screws.
7. Align the horn by rotating it, if necessary. Torque the carriage door to 20 in.-lbs to secure the stack.

Figure 4.20 Installing a 20 kHz Stack in a Branson Actuator

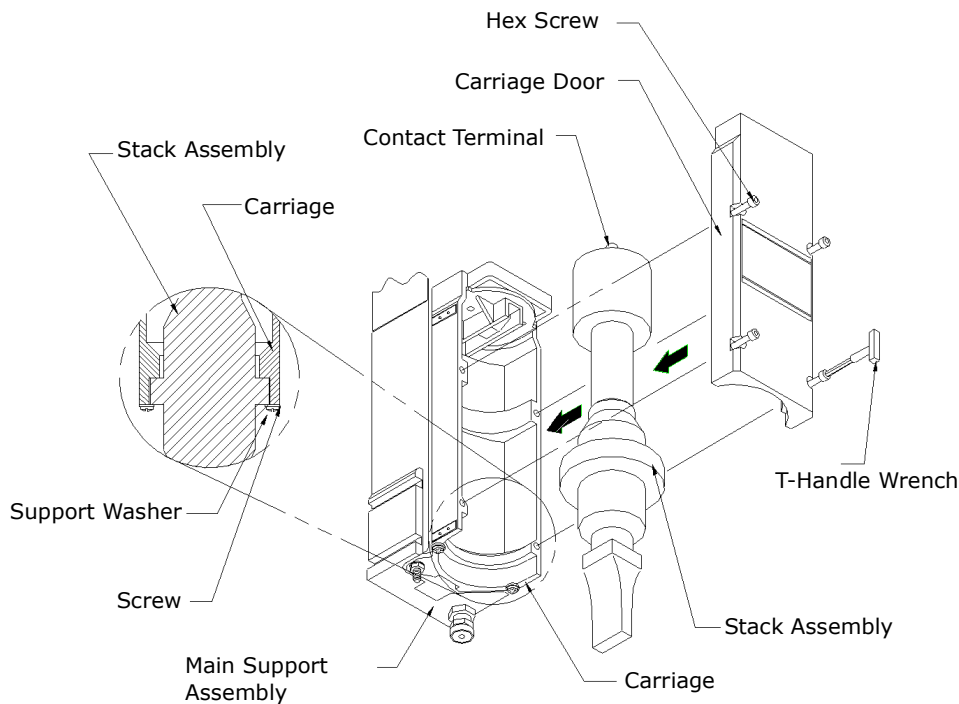



| NOTICE | |
|---|--|
|  | <p>Branson recommends using the CA-30 converter instead of the CJ-30 converter with the sleeve assembly.</p> |

4.10.2 40 kHz Stacks

1. Make sure the system power is turned off by disconnecting the power plug.
2. Place the converter/booster in the sleeve.
3. Loosen four carriage door screws.
4. Pull the door straight off and set it aside.
5. Take the assembled sleeve and align the ring nut on the booster just above the support washer in the carriage. Firmly push the sleeve into place, with the acorn nut on the top of the sleeve making contact with the contactor in the top of the carriage.
6. Reinstall the door assembly, and start the four door screws.
7. Align the horn by rotating it, if necessary. Torque the carriage door to 20 in-lbs to secure the stack.

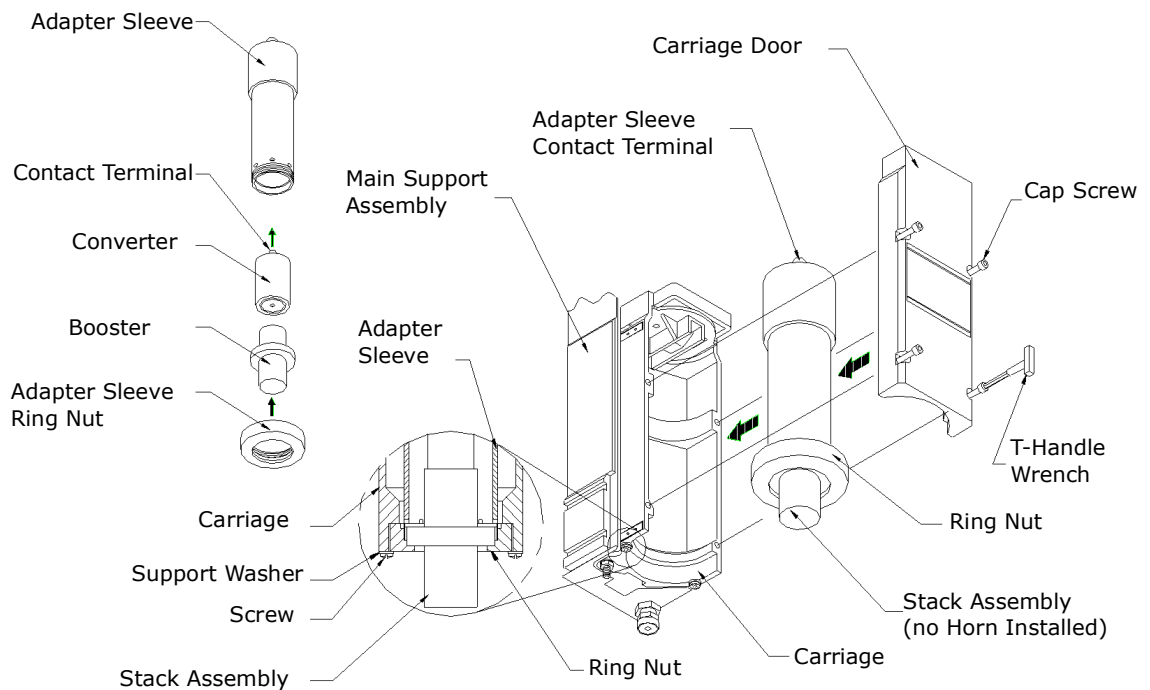
Figure 4.21 Installing the 40 kHz Stack in a Branson Actuator



| CAUTION | |
|---|--|
|  | <p>Do not attempt to hold the sleeve in a vise. It can be easily crushed or damaged.</p> |

4.10.3 Mounting the Fixture on the Branson Base (hardware and mounting holes)

The base provides mounting holes for your fixture. Mounting holes are also provided for the optional Branson leveling plate kit. The base is tapped for metric M10-1.5 hardware.

The mounting holes are arranged in three concentric bolt circles with the following dimensions.

| CAUTION | |
|---|---|
|  | <p>The base is cast metal and the mounting holes can become stripped if the hardware is overtightened. Tighten your hardware only enough to prevent movement of your fixture.</p> |

Figure 4.22 Mounting Circles on Base



The optional guard 101-063-550 (sometimes required with very large horns) is shown for position only. It extends several inches to either side of the base, and prevents the user from operating the welder and pinching their fingers or hands between the base and the tooling.

4.11 Testing the Installation

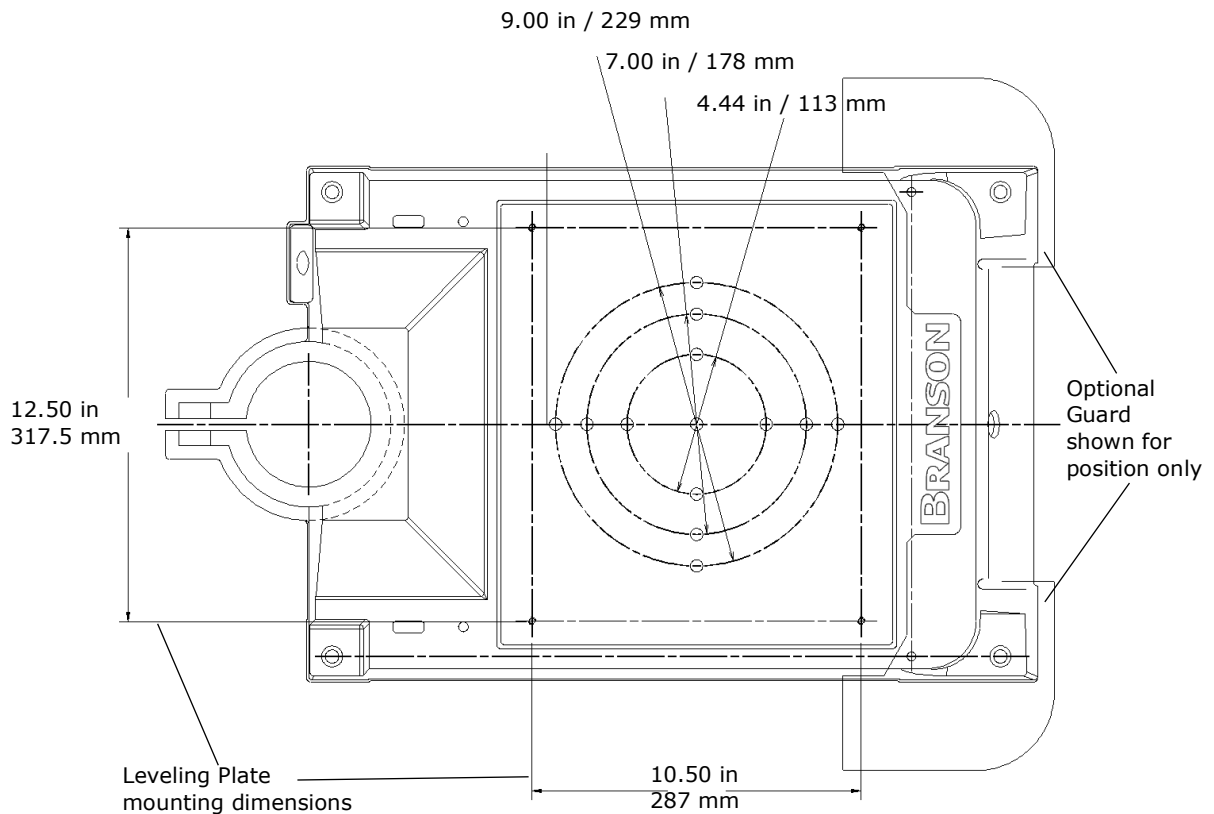
1. Turn on the air supply connections including the pneumatic dump valve and verify that the air pressure indicator light in the actuator is lit.
2. Ensure there are no leaks in the air supply connections.
3. Turn on the power supply. The power supply will begin its normal self-check.
4. If the power supply displays an alarm message other than Recalibrate Actuator, find the alarm message definition, cause and correction in [Chapter 7: Maintenance](#) of this manual. If the power supply displays the alarm message Recalibrate Actuator, or "Ready" appears in the power supply display, go on to the next step.
5. Perform an actuator calibration by touching the Main Menu button, and then touch the Calibration button. Verify that there is a minimum clearance from horn face to workpiece greater than 0.70".
6. Touch Cal Actuator.
7. In the screen that follows, touch w/Start Switches (Automation users select Manual Override).
8. Press the Start switches to complete the calibration.
9. Press the Test button.
10. If the power supply displays an alarm message at this point, find the alarm message definition in the Maintenance section of [Chapter 7: Maintenance](#) of the power supply manual. If there are no alarm messages displayed, go on to the next step.
11. Fit a test part onto the fixture.
12. Touch Horn Down on the Main Menu. The horn will descend to the fixture on the base of the Actuator. This verifies specifically that the pneumatic system is working.
13. Press the Retract button or any of the 4 buttons on the bottom row. The horn will retract. The system should now be functional and can be set up for your application.

In summary, if the power supply does not display an alarm message and the descends and retracts correctly, your ultrasonic welder is ready for operation.

Figure 4.23 Normal Front Panel Display after Power-Up

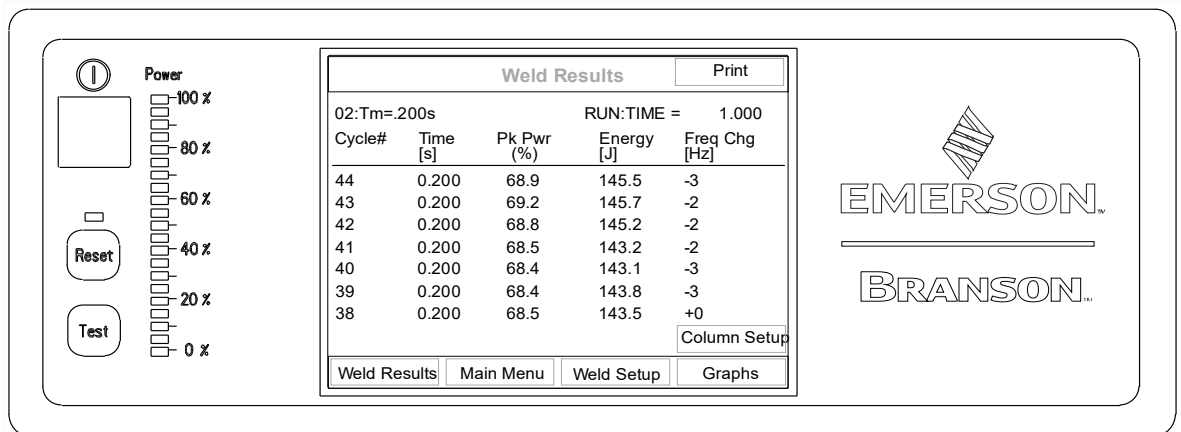

4.12 Still Need Help? or Parts? Have Questions?

Branson is pleased that you chose our product and we are here for you! If you need assistance with your 2000X-series system, call your local Branson representative or contact Branson customer service by calling the appropriate department as indicated on [Table 1.1 Branson Contacts](#), in Section [1.5.3 Departments to Contact](#).

Chapter 5: Technical Specifications

| | | |
|------------|--|-----------|
| 5.1 | Technical Specifications | 78 |
| 5.2 | Physical Description | 80 |
| 5.3 | Standard Modules and Components | 81 |

5.1 Technical Specifications

5.1.1 Environmental Requirements

The 2000X Power Supply has the following environmental requirements.

Table 5.1 Environmental Requirements

| Environmental Concern | Acceptable Range |
|------------------------------|----------------------------------|
| Ambient Temperature | +41°F to +122°F (+5°C to +50°C) |
| Storage/Shipping Temperature | -13°F to +158°F (-25°C to +70°C) |
| Humidity | 30% to 95%* non-condensing |

*Above 40°C the humidity drops to 90%

5.1.2 Electrical Requirements

The following tables list input voltage and current requirements for the 2000X Welding System, and includes power required when it is used with Branson 2000X-series Actuators.

Table 5.2 Electrical Input Operating Voltages

| Power Supply Rating | Nominal Input Operating Voltage, +/-10% |
|---------------------|--|
| 40 kHz / 400 W | 100-120, 200-240 V, 50/60 Hz, Single Phase |
| 40 kHz / 800 W | 100-120, 200-240 V, 50/60 Hz, Single Phase |
| 30 kHz / 1500 W | 200-240 V, 50/60 Hz, Single Phase |
| 20 kHz / 1250 W | 100-120, 200-240 V, 50/60 Hz, Single Phase |
| 20 kHz / 2500 W | 200-240 V, 50/60 Hz, Single Phase |
| 20 kHz / 4000 W** | 220-253 V, 50/60 Hz, Single Phase |
| 15 kHz / 3300 W* | 200-240 V, 50/60 Hz, Single Phase |

Table 5.3 Input Current and Fuse Requirements

| Model | Power | Current Rating |
|-------------------|-----------------------|-----------------------------------|
| For 15 kHz models | 3300 W 200 V - 240 V | 21 Amp Max. @ 220 V / 20 Amp fuse |
| For 20 kHz models | 1250 W 200 V - 240 V | 7 Amp Max. @ 200 V / 20 Amp fuse |
| | 1250 W 100 V - 120 V | 14 Amp Max. @ 100 V / 20 Amp fuse |
| | 2500 W 200 V - 240 V | 14 Amp Max. @ 200 V / 20 Amp fuse |
| | 4000 W* 220 V - 253 V | 25 Amp Max. @ 220 V / 25 Amp fuse |

Table 5.3 Input Current and Fuse Requirements

| Model | Power | Current Rating |
|-------------------|----------------------|-----------------------------------|
| For 30 kHz models | 750 W 100 V - 120 V | 10 Amp Max. @ 100 V / 20 Amp fuse |
| | 750 W 200 V - 240 V | 5 Amp Max. @ 200 V / 20 Amp fuse |
| | 1500 W 200 V - 240 V | 10 Amp Max. @ 200 V / 20 Amp fuse |
| For 40 kHz models | 400 W 200 V - 240 V | 3 Amp Max. @ 200 V / 20 Amp fuse |
| | 400 W 100 V - 120 V | 5 Amp Max. @ 100 V / 20 Amp fuse |
| | 800 W 200 V - 240 V | 5 Amp Max. @ 200 V / 20 Amp fuse |
| | 800 W 100 V - 120 V | 10 Amp Max. @ 100 V / 20 Amp fuse |

Cycle Rate – up to 200 cpm. Cycle rate including off time is application and stack dependent.

*This unit is rated at a 25% duty cycle with 5 second On time, 1600W continuous.

**This unit is rated at a 25% duty cycle with 5 second On time, 2000W continuous. Rated power is 4000 W at 40°C.

5.1.3 Pneumatic Requirements

The factory compressed air supply must be “clean (to a 5 micron level), dry and unlubricated” air with a regulated maximum pressure of 100 psig (690 kPa). Depending on your application, the actuator requires between 35 to 100 psi. Stands include an in-line air filter. Actuators (alone) require a customer-provided air filter. A quick-disconnect fitting is suggested. Use a lockout device on the air line if required.

Air Filter

Actuators (alone) require a customer-provided air filter which protects from particulate matter of 5 microns or larger. If a stand is mounted in a position other than upright (vertical), its air filter must be relocated and oriented so its bowl is the lowest point, and the air flow across the air filter is horizontal. This may require some re-plumbing of the existing equipment at the customer site. The air filter is held in place by two screws on a bracket bolted to the actuator support, and by the factory-installed tubing.

Pneumatic Tubing and Connectors

Actuator assemblies are not externally plumbed from the factory, but provide conventional 1/4-inch OD pneumatic tubing connection at the air inlet. If making connections for an actuator, or if re-plumbing your system for a new air filter location, you must use 1/4-inch OD tubing and connectors rated above 100 psi (use Parker "Parflex" 1/4 OD x.040 wall, type 1, grade E5, or equivalent), and appropriate connectors.

Pneumatic Connections to Actuator

*aed actuators require clean, dry input air at 100 psi filtered to 5 microns.

5.2 Physical Description

The 2000X Power Supply is part of an industrial system that can be used for ultrasonic welding, inserting, staking, spot welding, swaging, and degating thermoplastic parts, and for cutting and sealing thermoplastic fabric and film. Branson 2000X distance Power Supplies can operate with Actuators in manual, semi-automated, or automated systems.

Figure 5.1 Rear View of 2000X Power Supply

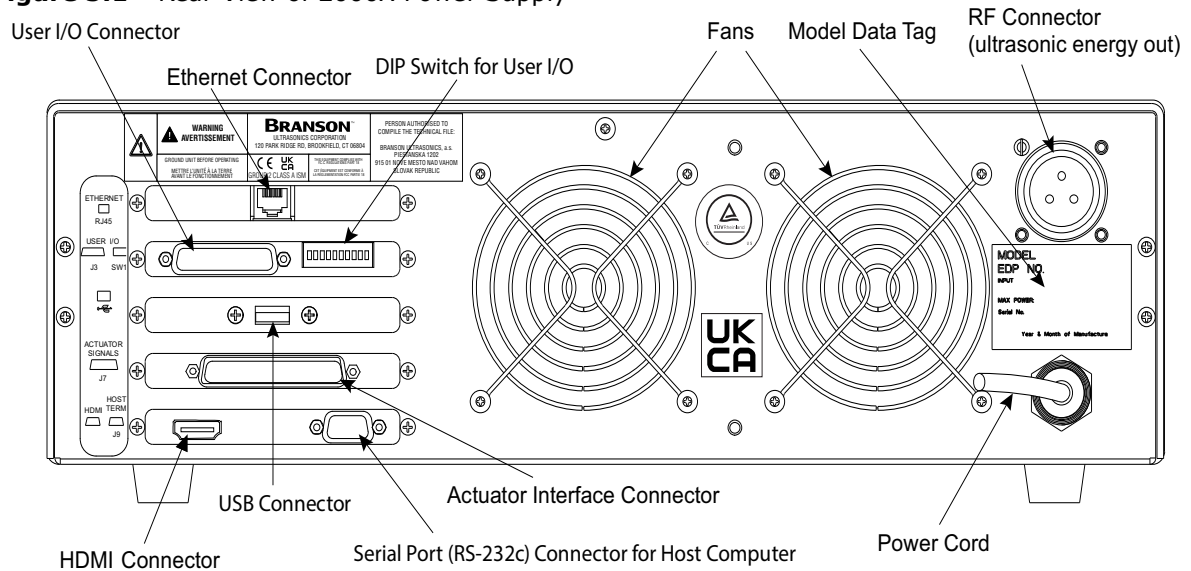

The 2000X-Series Power Supply is the combination of two welding system elements in one enclosure. These elements are a power source for ultrasonic energy and a major portion of the welding system control, including the user interface. The enclosure is a standard 19" rack-mount compatible design, and can be stacked or installed up to three units high. Its design is readily convertible from its normal desktop configuration for standard 19-inch rack mount applications by adding the rack mount handles (available as a kit). The Chassis is approximately 20 inches (51 cm) in depth.

The 2000X's control system is microprocessor-based, and controls the welding process while providing a level of user interface through a membrane keypad and alpha-numeric display. It employs fan-forced cooling, and is intended for horizontal placement. The front panel display and user controls are intended to be accessible from a comfortable position for an end user (operator), which means that the unit will often be installed approximately 3 to 5 feet off the floor.

The User I/O interface capabilities allow you to connect a printer or other serial device. See [4.6.2 User I/O Interface](#) for further information.

5.3 Standard Modules and Components

The following sections describe the 2000X internal circuits.

5.3.1 Circuit Descriptions

The 2000X Power Supply contains the following modules:

- Line Board
- System Control Board
- Ultrasonic Power Module
- DC Power Module
- User I/O

The following sections contain descriptions for each module.

Line Board

The Line Board performs the dual function of providing RFI filtering for the line voltage input to the power supply, and controlling the electrical current surge to the ultrasonic Power Supply Module at power up until the inrush current limiter relay engages. The filtering also blocks ultrasonic signals from entering the AC main line. Additionally, the Line Board contains a soft start circuit module which limits the effects of current inrush.

System Control Board

The System Control Board controls the following functions of the Power Supply:

- Responding to start and stop signals
- Responding to alarm and reset signals
- Responding to user input from the front panel
- Activating and monitoring ultrasonics
- Provides information for Front Panel Displays
- Generate alarms
- Activate printing
- Control communications

Ultrasonic Power Supply

The Ultrasonic Power Supply Module generates ultrasonic energy at the resonant frequency of your Converter-Booster-Horn Stack. The Ultrasonic Power Supply Module is configured as either analog or digital, and each contains five main circuits. The analog power supply has one preset which calls up the factory default setting. The digital power supply has a library of locked presets which are accessible for various process parameter modifications that are unique to the power supply itself. These modifications can be named to reflect specific applications, and are loaded into memory prior to shipment from the Branson factory. The parameters of the individual presets can be modified by a Branson representative. Initially all presets are set to factory default. They are accessed via an RS-232c link to the system controller.

- **320VDC Power Supply:** converts AC line voltage to +320VDC for the output power devices.
- **Output circuit:** matches the impedance of the output power device to the Converter-Booster-Horn Stack; and provides feedback to the Control circuit.
- **Control circuits:** perform the following functions:
 - Provide drive signal to output power device.
 - Determine true percentage of ultrasonic power used over a range of amplitudes.

- Allow control of the resonant frequency.
- Control starting amplitude.
- **System Protection Monitor (SPM) and AutoTune with Memory (AT/M) circuit** do the following:
 - Provide overload protection for the Ultrasonic Power Module.
 - Store operating frequency of last weld (frequency memory) and use the stored frequency as a starting point for the next weld.
 - Check and update frequency memory on start-up.
 - Provide switch-selective starting ramp times (Start).

DC Power Module

The Switching DC Power Module rectifies, filters, and regulates the AC voltages from the Line Transformer into DC voltages for the System Control Module. These two circuits are described below:

- **5VDC output:** provides +5VDC for the analog and digital circuitry on the System Control Module.
- **24VDC output:** provides +24VDC for the System Control Module control signal and user I/O voltage.

User I/O

The User I/O board provides a standard interface for automation and is accessed on the rear of the power supply at J3. It gives the customer the ability to make their own interface for automation or special control and/or special reporting needs. Electrical interface outputs may be configured for open collector mode or for signal mode (signal voltage levels as indicated) by setting the User I/O DIP switch located next to J3.

5.3.2 Converters and Boosters

A variety of converters and boosters available, for use with the 2000X Power Supply, are illustrated in the following pages.

Figure 5.2 20 kHz CR20 Converter Dimensions

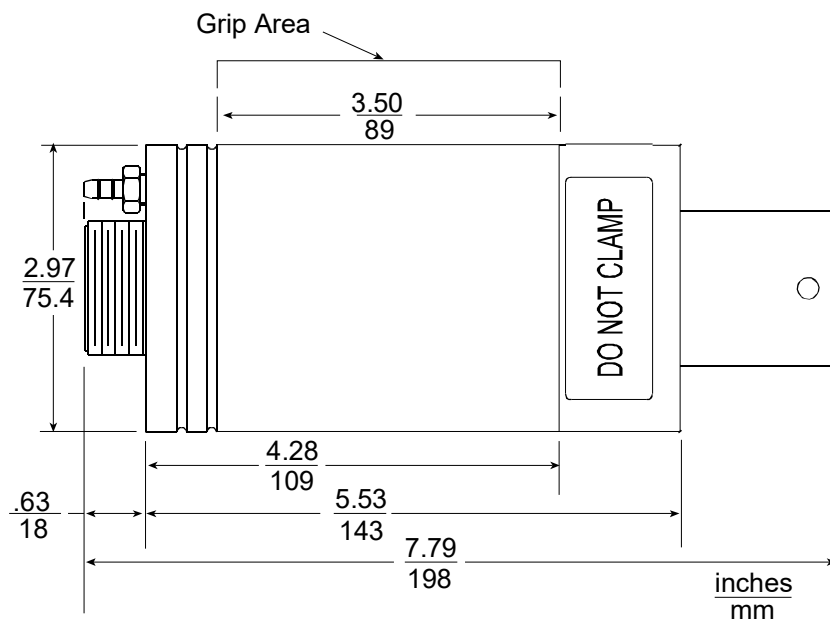

Figure 5.3 20 kHz Booster Dimensions

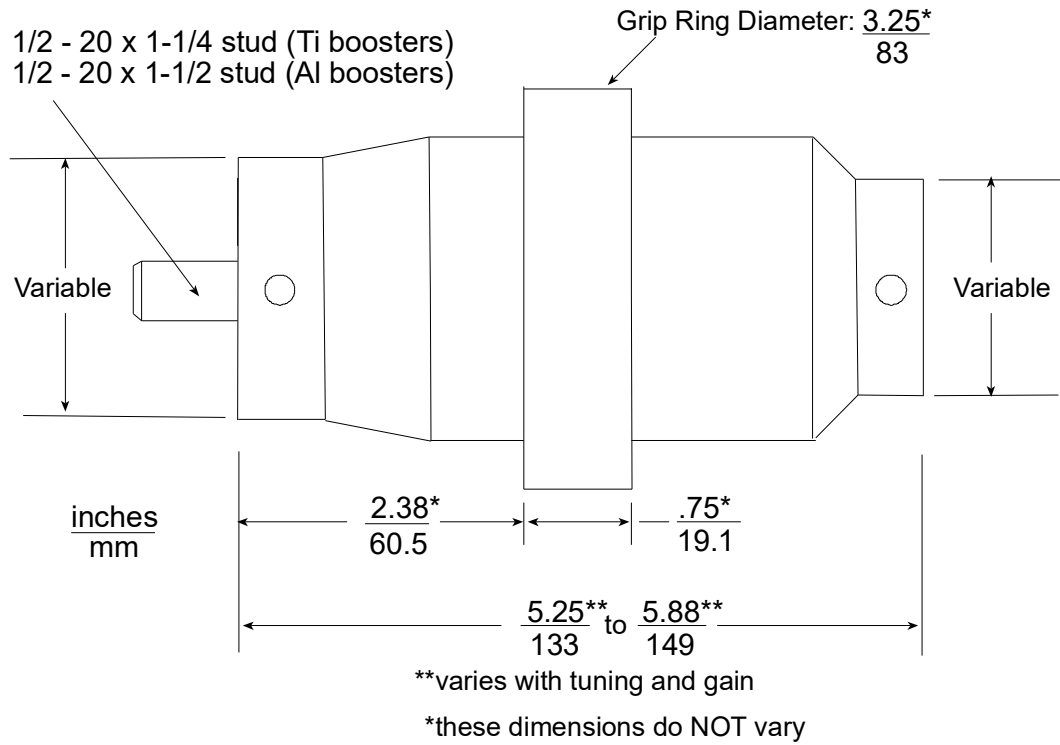

Figure 5.4 20 kHz Converter/Booster/Horn, Typical Dimensions

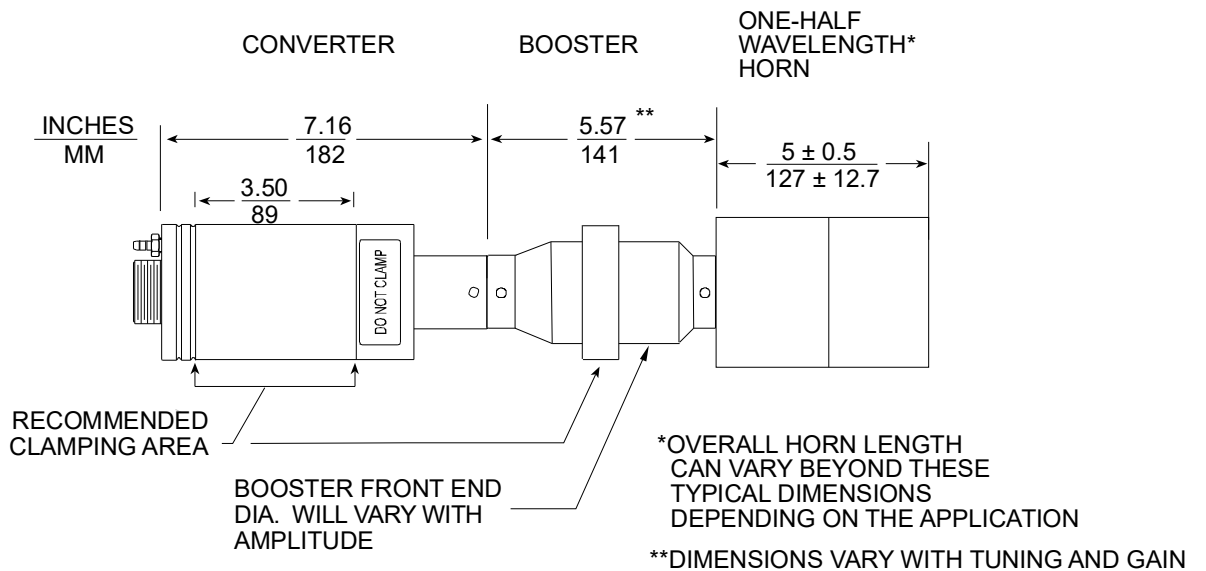

Figure 5.5 30 kHz Converter Dimensions

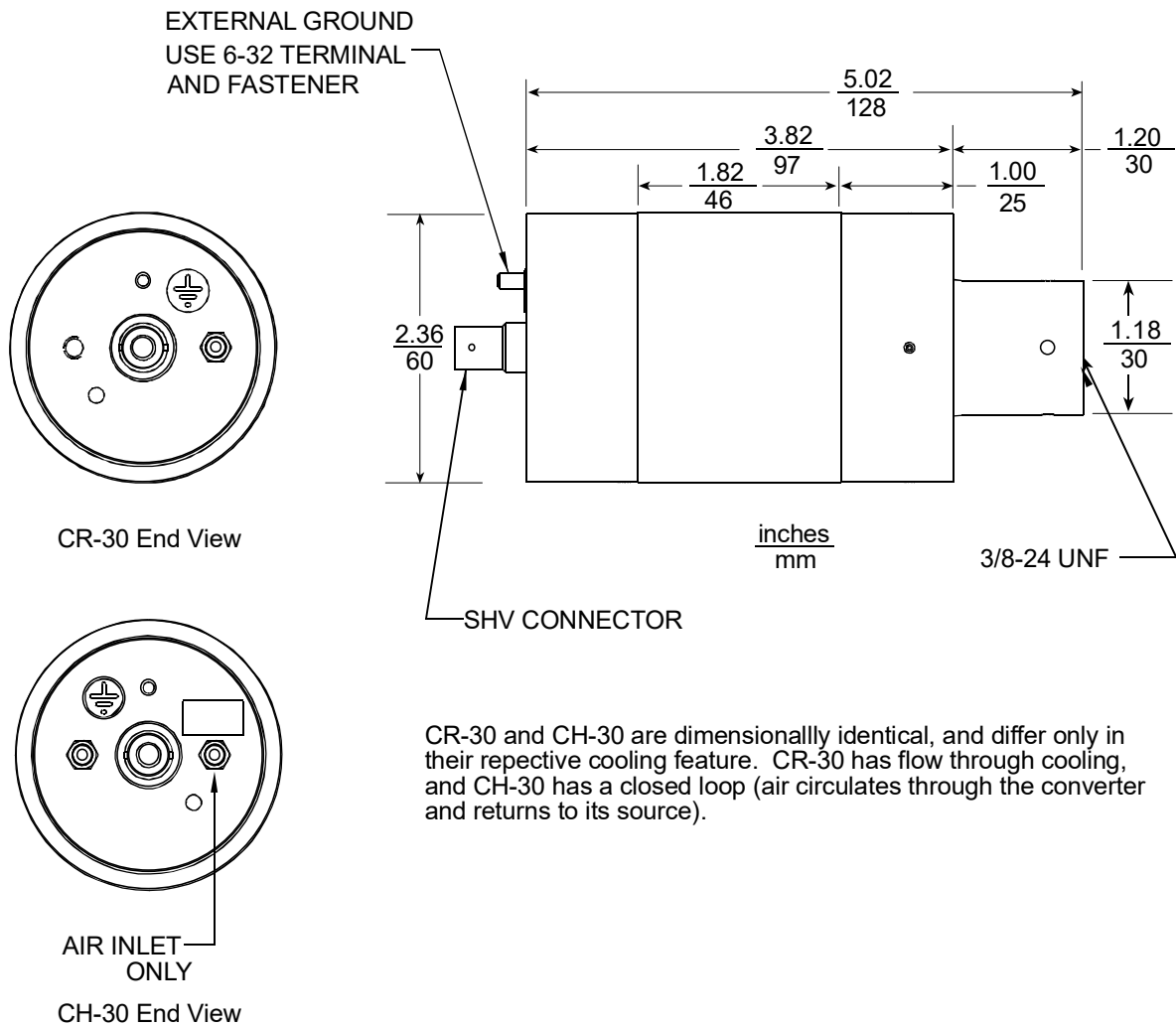

Figure 5.6 30 kHz Booster Dimensions

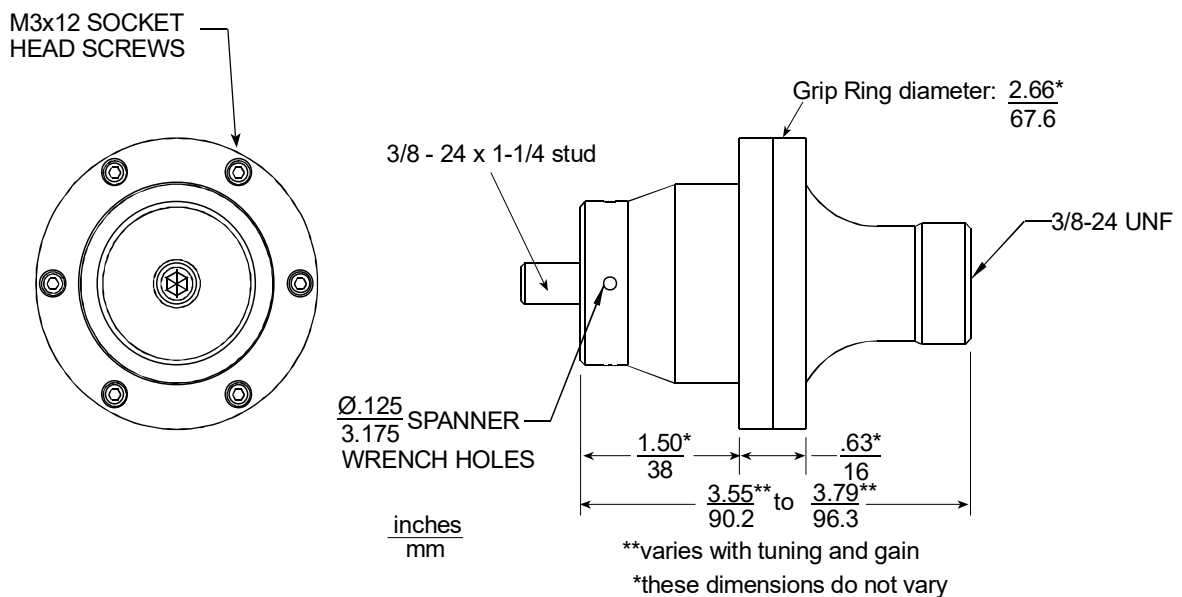

Figure 5.7 30 kHz, CA - 30 Converter with Booster

The CCA - 30 converter (EDP 159-135-114) is available in CA - 30 Converter Kit (EDP 101-063-689). Instructions for installing must be adhered to and are included in the Installation Instructions.

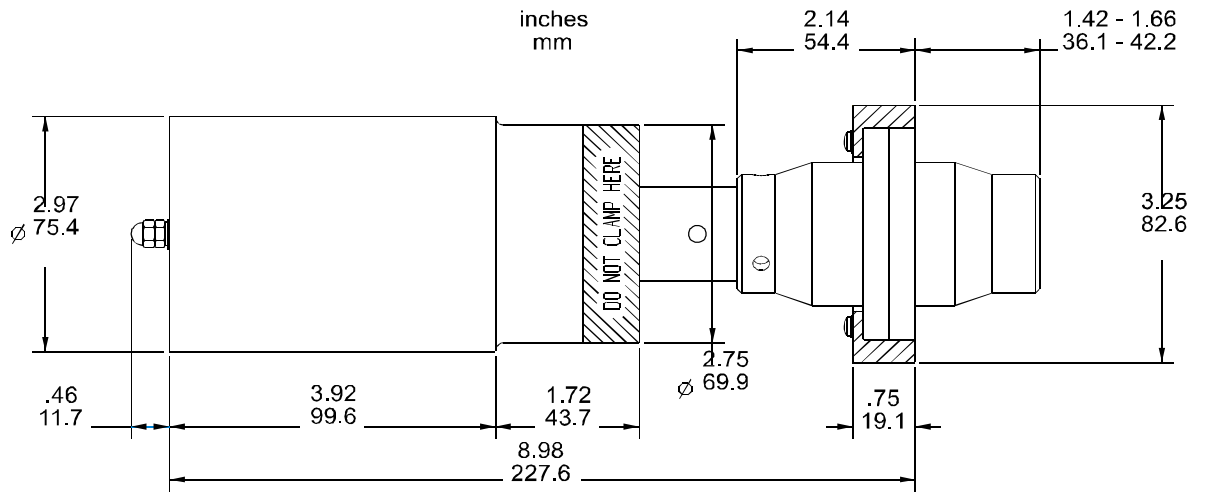

Figure 5.8 30 kHz Converter/Booster/Horn, Typical Dimensions

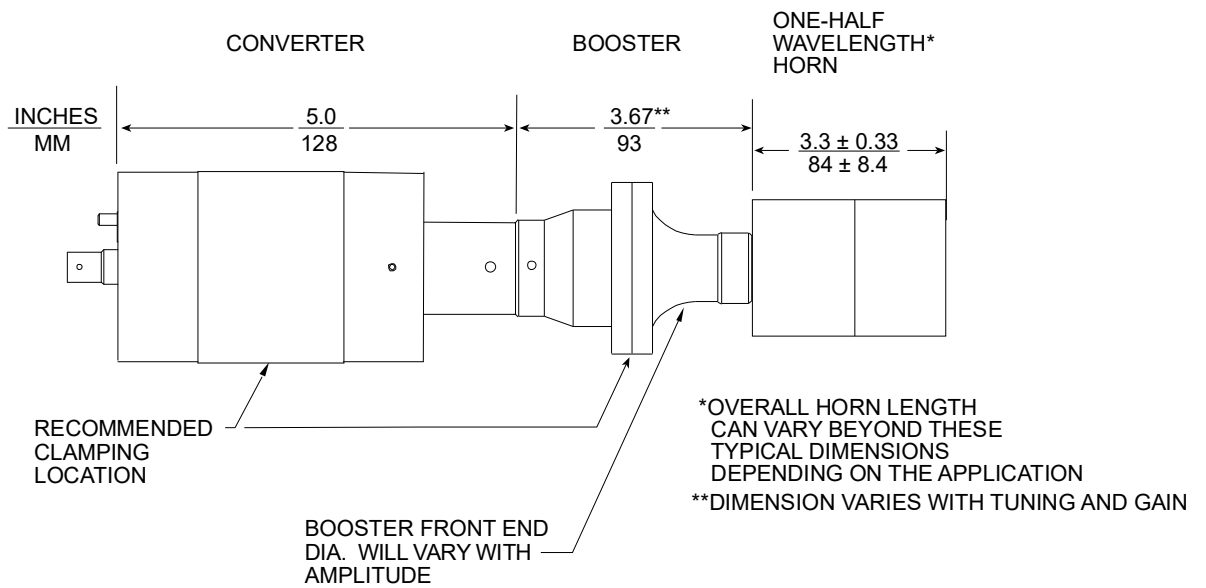

Figure 5.9 40 kHz, 4TR and 4TJ Converter Dimensions

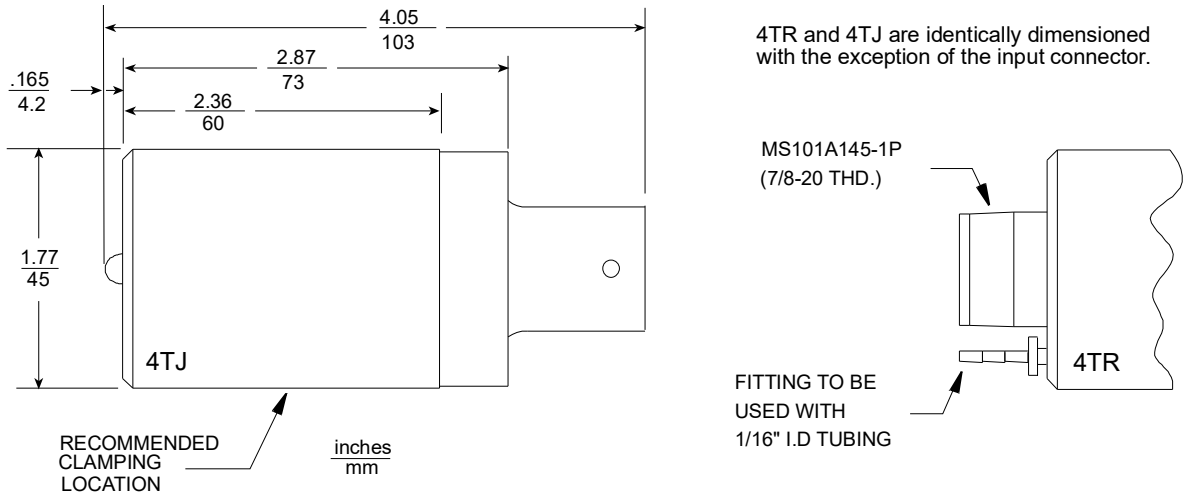

Figure 5.10 40 kHz, 4TH Converter Dimensions

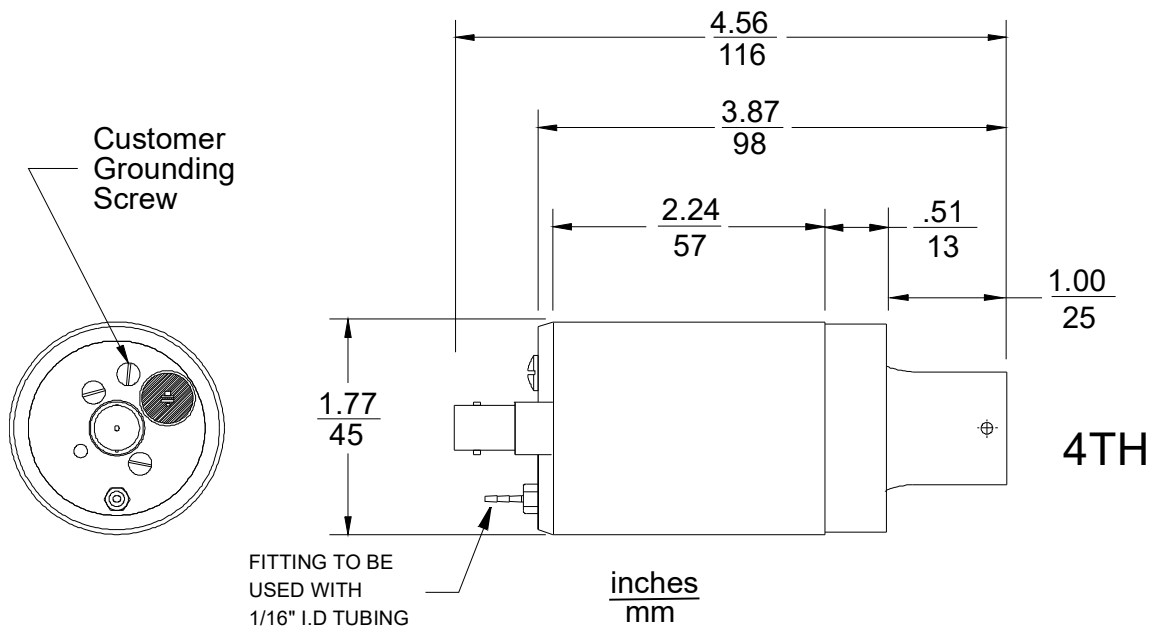

Figure 5.11 40 kHz, 4TP Converter Dimensions

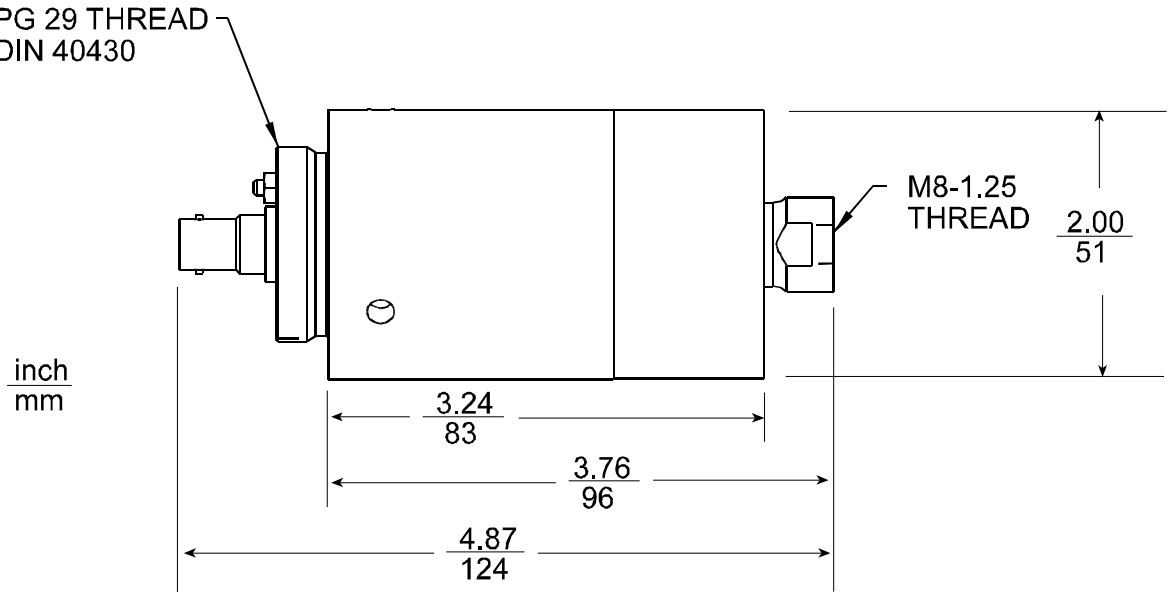

Figure 5.12 40 kHz Booster Dimensions

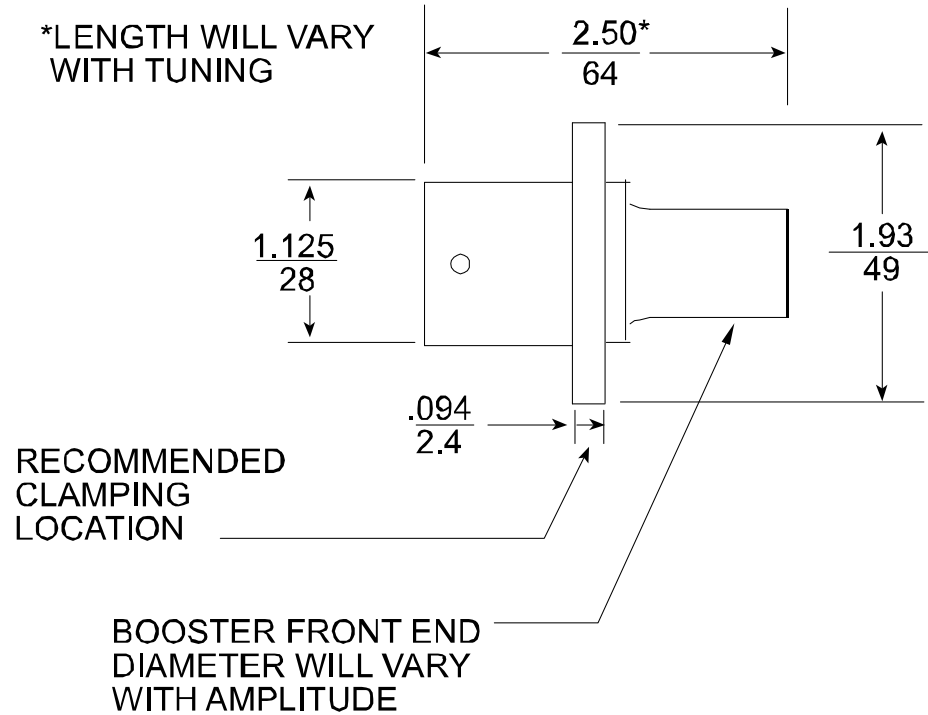
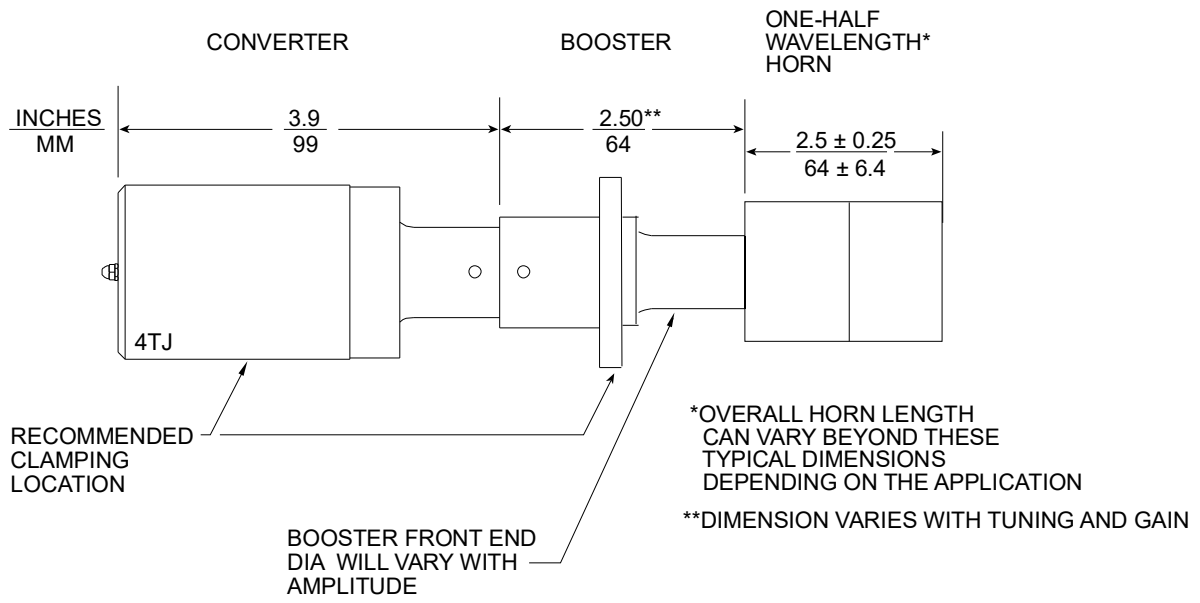



Figure 5.13 40 kHz Converter/Booster/Horn, Typical Dimensions



Chapter 6: Operation

| | | |
|------------|---|------------|
| 6.1 | Operating System | 90 |
| 6.2 | 2000X External Communication Functions | 92 |
| 6.3 | 2000X Distance Power Supply External Communication Functions | 93 |
| 6.4 | Front Panel Controls | 101 |
| 6.5 | System Menus | 109 |
| 6.6 | Using the Main Menu | 112 |
| 6.7 | Using the Weld Setup Menu | 140 |

| WARNING | |
|--|---|
|  | <p>High voltage is present in the 2000X Power Supply. When setting up and operating the welding system, observe the potential hazards listed below.</p> |

Do not operate the Power Supply with the cover removed.

- To prevent the possibility of electric shock, always plug the 2000X into a grounded power source.
- Keep hands out from under the horn. Down-force (pressure) and ultrasonic vibrations can cause injury.
- Large plastic parts can vibrate within the audible frequency range when welded. If this occurs, use hearing protectors to prevent possible injury.
- Do not press the Test switch or cycle the welding system if either the RF cable or the converter is disconnected. High voltage could be present at open power connections.
- When using larger horns, avoid situations in which fingers could be pinched between the horn and the fixture.
- Assure power switch is in the OFF position before making or breaking any electrical or pneumatic connections to the Power Supply, Actuator or Welder.
- Do not touch Ultrasonic Horn during or immediately following the welding cycle. Vibrations and heat can burn skin.

| CAUTION | |
|---|--|
|  | <p>Do not allow a vibrating horn to touch a metal base or metal fixture.</p> |

6.1 Operating System

The 2000X Distance Power Supply uses an embedded Single Board Computer (SBC) to offer advanced user interface functions. It uses Windows 10 IoT Enterprise LTSC as its operating system.

6.1.1 UWF Configuration Utility

To protect the application and the operating system, Windows 10 IoT Enterprise LTSC employs Windows Unified Write Filter. This filter uses a RAM overlay to record changes to the Solid State Drive. Any changes made to the C: drive are lost during a power cycle. Only the C:\Branson folder remains unprotected allowing the 2000X Distance Power Supply application to write directly to the Storage Drive to save presets, sequences, setup parameters and log files.

The UWF must be disabled before modifying the Windows 10 IoT Enterprise LTSC configuration. Changes made to Windows configuration such as Local Area Network configuration will be lost if the UWF has not been previously disabled. Once all changes have been saved, the UWF must be re-enabled before resuming controller operations. Contact customer support if this becomes necessary ([1.4 How to Contact Branson](#)).

Figure 6.1 UWF Configuration Utility

```
=====
UWF Management Menu
=====

1. Enable Disk Protection
2. Disable Disk Protection
3. Add a File/Folder to the Exemption List
4. Remove a File/Folder from the Exemption List
5. Exit

Enter option number:
```

6.1.1.1 Disabling the UWF Manager

1. Open the UWF Manager. Click on Windows → File Explorer → C:\UWF Configuration Utility\UWF Configuration Utility.exe → Right Click → Run as Administrator.
2. Select option 2.
3. Wait for SBC to reboot.

6.1.1.2 IP Address Setup

Network Connection

The following procedure is for connecting to a network.

1. Connect the welder to the network by inserting the shielded Ethernet cable into the Ethernet port on the back of the power supply and the network drop.
2. Select Windows setup screen from the 2000X Distance controller.
3. From the Windows screen select: Start → Control Panel → Network and Internet → Network and Sharing Center → Change Adapter Settings.
4. Double click on "Ethernet". Click Properties.
5. Under Internet Protocol (TCP/IP), set to obtain an IP automatically.
6. Now you are ready to begin the communication setup.

6.1.1.3 Point to Point Connection with a Cross-Over Ethernet Cable

If a network does not exist, a shielded Ethernet cable can be used for a point to point connection between a computer and the 2000X Distance Power Supply. The connection can be made using a crossover Ethernet Cable.

1. Select Windows setup screen from the 2000X Distance controller.
2. From the Windows screen select: Start → Control Panel → Network and Internet → Network and Sharing Center → Change Adapter Settings.
3. Double click on "Ethernet". Click Properties.
4. Under Internet Protocol (TCP/IP V4), set the following IP address manually.
5. Set your IP address.

For point-to-point connection use a setting for the P/S, for example:

IP: 192.168.10.100

Subnet Mask: 255.255.255.0

Gateway: 192.168.10.1

In this case, your computer will need the following setting:

IP: 192.168.10.101

Subnet Mask: 255.255.255.0

Gateway: 192.168.10.1

6. Select OK (twice).
7. Close this window by clicking on the "X" on the upper right corner

6.1.1.4 Re-enabling the UWF Manager

1. Open the UWF Manager. Click on Windows → File Explorer → C:\UWF Configuration Utility\UWF Configuration Utility.exe → Right Click → Run as Administrator.
2. Select option 3.
3. Enter C:\Branson\
4. Select option 1.
5. Wait for SBC to reboot.

6.2 2000X External Communication Functions

6.2.1 Branson X-Net™ Setup

Branson X-Net is a method of remotely communicating with a Branson 2000X touch screen welder. It is a bi-directional control technique that allows the user to remotely monitor and control the operation of the welder from a networked PC.

Note: You can not use this to link to a PLC for the user I/O. That is a separate function.

Two options are available for networking the welder:

1. In many companies, a computer network already exists. In this case, a network Ethernet drop can be installed near the welder. You will need to use a shielded Ethernet cable to connect the welder (the port is on the back of the power supply) to the network.



NOTICE



If there is a firewall on the network, you will only be allowed to view the welder within the network unless the company's IT department grants the computer outside the network access.

2. If a network does not exist or if a direct link to a single PC is desired, you can use an Ethernet Switch to link the welder to the PC.

Before you begin the setup, you will need the following:

- A USB mouse for the welder
- A shielded Ethernet cable for connecting to the network
- Remote Desktop functionality enabled in your PC

6.3 2000X Distance Power Supply External Communication Functions

6.3.1 2000X Distance Remote Desktop Communication

With Remote Desktop Connection, you can connect the 2000X Distance P/S with a Windows based computer that's connected to the same network and it allows the user to remotely monitor and control the operation of the welder.

Two options are available for networking the welder:

- In many companies, a computer network already exists. In this case, a network Ethernet drop can be installed near the welder. You will need to use a shielded Ethernet cable to connect the welder (the port is on the back of the power supply) to the network

| NOTICE | |
|---|---|
|  | <p>If there is a firewall on the network, you will only be allowed to view the welder within the network unless the company's IT department grants the computer outside the network access.</p> |

- If a network does not exist or if a direct link to a single PC is desired, you can use an Ethernet cable to link the welder to a Point-to-Point connection

Before you begin the setup, you will need the following:

- A USB mouse and keyboard for the welder
- A shielded Ethernet cable for connecting to the network

6.3.1.1 Windows Setup

From the System Configuration menu, select Windows Setup.

Figure 6.2 System Configuration Menu

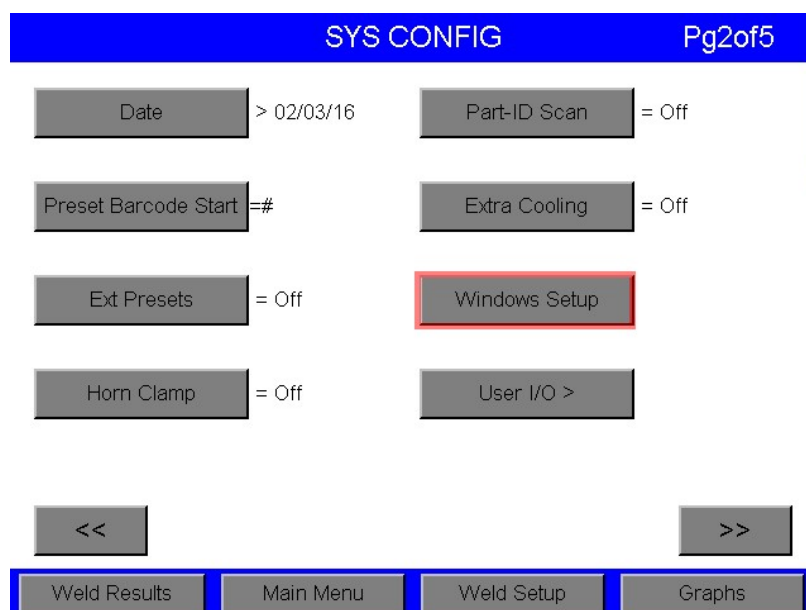

6.3.1.2 Disabling the UWF Manager

1. Open the UWF Manager. Click on Windows → File Explorer → C:\ UWF Configuration Utility\UWF Configuration Utility.exe → right click → Run as Administrator.
2. Select option 2.
3. Wait for SBC to reboot.

6.3.1.3 IP Address Setup

| NOTICE | |
|---|---|
|  | A mouse and keyboard connected to the USB port is necessary to navigate through the next several steps. |

Network Connection

The following procedure is for connecting to a network.

1. Connect the welder to the network by inserting the shielded Ethernet cable into the Ethernet port on the back of the power supply and the network drop.
2. Select Windows setup screen from the 2000X Distance controller.
3. From the Windows screen select: Start → Control Panel → Network and Internet → Network and Sharing Center → Change Adapter Settings.
4. Double click on "Ethernet". Click Properties.
5. Under Internet Protocol (TCP/IP), set to obtain an IP automatically.
6. Now you are ready to begin the communication setup.

Point to Point Connection with a Cross-Over Ethernet Cable

If a network does not exist, a shielded Ethernet cable can be used for a point to point connection between a computer and the 2000X Distance Power Supply. The connection can be made using a crossover Ethernet Cable.

1. Select Windows setup screen from the 2000X Distance controller.
2. From the Windows screen select: Start → Control Panel → Network and Internet → Network and Sharing Center → Change Adapter Settings.
3. Double click on "Ethernet". Click Properties.
4. Under Internet Protocol (TCP/IP V4), set the following IP address manually.
5. Set your IP address.

For point to point connection use a setting for the P/S, for example:

IP: 192.168.10.100

Subnet Mask: 255.255.255.0

Gateway: 192.168.10.1

In this case, your computer will need the following setting:

IP: 192.168.10.101

Subnet Mask: 255.255.255.0

Gateway: 192.168.10.1

6. Select OK (twice).
7. Close this window by clicking on the "X" on the upper right corner.

6.3.1.4 Re-enabling the UWF Manager

1. Open the UWF Manager. Click on Windows → File Explorer → C:\UWF Configuration Utility\UWF Configuration Utility.exe → Right Click → Run as Administrator.
2. Select option 3.
3. Enter C:\Branson.
4. Select option 3 again.
5. Enter C:\Branson\SystemConfig.cfg
6. Select option 1.
7. Wait for SBC to reboot.

| NOTICE | |
|---|---|
|  | The power supply needs to be restarted for new IP to take effect. |

6.3.2 Branson Remote Desktop Setup (without front display access)

The following procedure is for connecting to a network or point to point connection.

1. Please disable the UWF (Section [6.3.1.1 Windows Setup](#) to section [6.3.1.2 Disabling the UWF Manager](#)).
2. Connect the welder to the network by inserting the shielded Ethernet cable into the Ethernet port on the back of the power supply and the network drop, or if a network does not exist, the shielded Ethernet cable can be used for a point to point connection between a computer and the 2000X Distance Power Supply.
3. From the System Configuration menu, select Windows Setup.
4. Go to Start → Control Panel → Administrative Tools → Local Security Policy → Local Policies → Security Options → Accounts: Limit local account use of blank passwords to console logon only and set the option to Disabled, and you will be able to remote desktop without the need for a password.

Figure 6.3 Local Security Setting

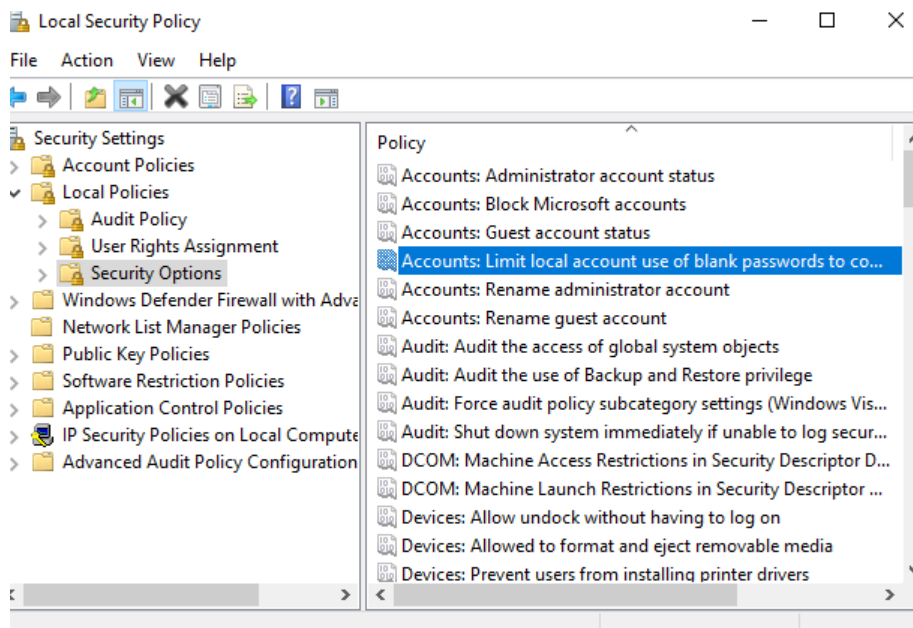

5. Reboot the P/S. The P/S will start up in the Main Menu Screen. Go to page 2 of the menu and click on Windows Setup to go back to Windows.

Figure 6.4 Windows Setup

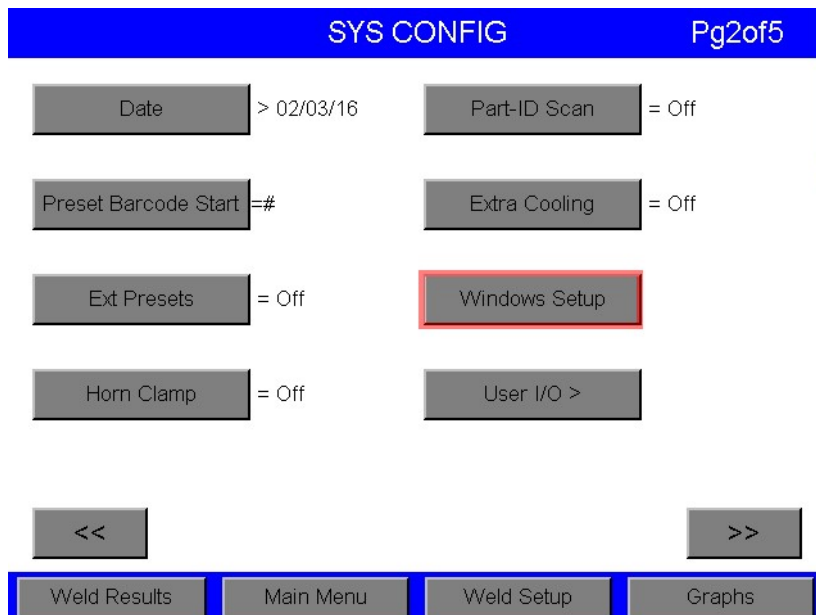

6. Enable the UWF. See [6.3.1.4 Re-enabling the UWF Manager](#).
7. On the computer, click on Start → All Programs → Accessories → Remote Desktop connection, enter the welder IP address in the Server box, click OK. See [Figure 6.5 Server Box](#).

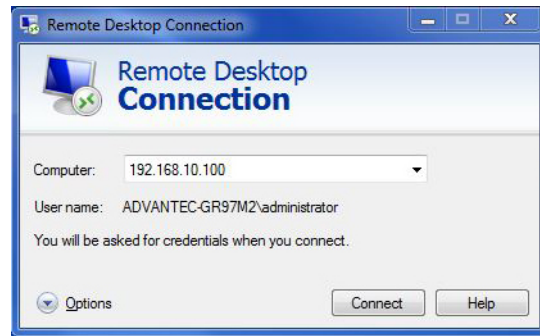
Figure 6.5 Server Box

8. Log on as administrator (without password).
9. The computer is now directly linked to the welder. You are now equipped to monitor the actions on the welder or control the welder from the PC. You can perform any function on the welder with the exception of initiating a cycle. You can actually have multiple PC linked to the welder simultaneously.

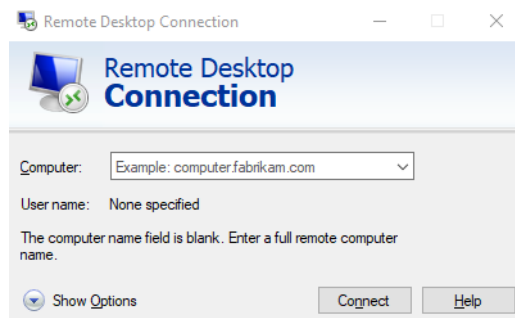
Figure 6.6 Remote Desktop Connection

6.3.3 Branson Remote Desktop Setup (with Front Display Access)

Remote Access does not allow to activate the P/S front display by default.

In case the customer requires to be able to use the P/S front display without restarting the P/S, then the security setting needs to be changed.

| NOTICE | |
|---|--|
|  | <p>This change reduces the security of the system!</p> |

1. Please disable the FBWF (Section [6.3.1.1 Windows Setup](#) to Section [6.3.1.2 Disabling the UWF Manager](#)).
2. Go to Start → Control Panel → Administrative Tools → Local Security Policy → Local Policies → Security Options → interactive logon: Do not require CTRL + ALT + DEL and set the option to Enabled. Click OK.

Figure 6.7 Enable “Do not require CTRL + ALT + DEL”

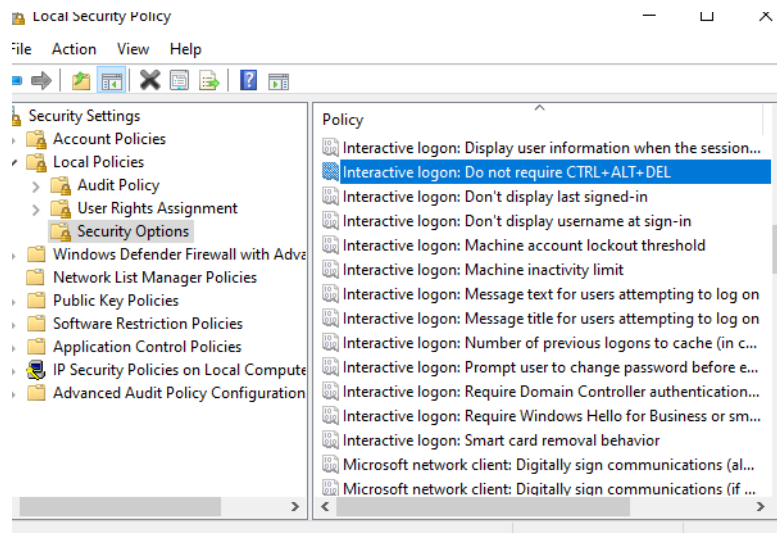

3. Start the “2000X” software on the desktop.

Figure 6.8 2000X Distance File on the desktop



- 4. Restart the P/S.
- 5. Please enable the FBWF ([6.3.1.4 Re-enabling the UWF Manager](#)).
- 6. If the remote access is active, the P/S front display shows the log on window. If you log on as administrator (without password), the remote access will be denied and the front display has the full access again.

Figure 6.9 Remote Desktop Connection

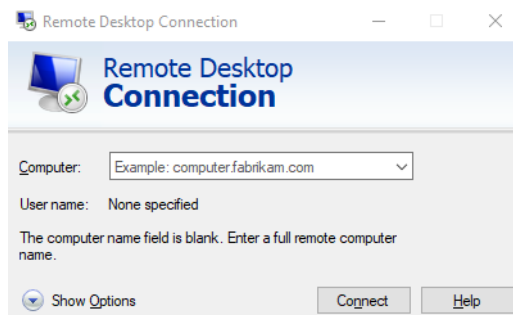

6.3.4 USB

The two USB ports available on the 2000X power supply are USB 2.0 compliant, allowing complete plug and play, and hot attach/detach for up to 127 external devices. USB 2.0 is fully backward compatible with USB 1.1, supporting speeds of 1.5, 12 and 480 Mbps. For example, keyboard and mouse can be used with USB port at low speed, while printer and USB memory stick will run at High-speed. Information can be transferred to a PC using the Branson History Utility to view and process information. This can be useful when weld history data requirements exceed the maximum of 50 weld history data that can be stored in the power supply.

To download data and graphs, a memory stick must be inserted into the USB port (or hub). Then activate the communication through the touch screen Main Menu:

- Enter the System Configuration menu. Located on the first screen is the USB DATA button.
- Once in this menu, you need to switch the USB to On.
- Select the weld data or graphs you would like to download. When selecting these, the user has the option of either downloading after a weld cycle (and at what interval, i.e., 1, 5, 20, 100, etc.) and/or when an alarm takes place.

The storage capacity of the memory stick will determine the number of cycles and graphs the stick can hold. The data space required for each weld cycle is: 1.0 KB for weld data and 1.35 KB for each graph.

| NOTICE | |
|---|---|
|  | <p>It is important to remember to turn off the USB feature prior to removing the memory stick; an alarm will be generated if the stick is simply removed.</p> |

To view the stored data on a PC you may use Branson's history utility program History.exe. (See the following section for further information.)

6.3.5 Branson History Utility

The Branson History Utility program is used to display weld history results from the 2000X power supply on a PC. (See the previous section for more information on the 2000X power supply's USB storage feature.)

Procedure for using the program:

1. Install Branson History Utility program on a PC running Windows 2000 or XP.
2. Insert the USB memory stick into the PC.
3. Run the History Utility program. Click on "File", then select either "Open P/S folder" or "Open Horn Scan". The window will display the drives available to the PC. Click on the USB drive and

select the folder named with the P/S serial number. The software loads the information and enables you to view data and graphs.

| NOTICE | |
|---|---|
|  | From this utility you can also print weld data, graphs, and horn scan data. |

6.3.6 VGA Monitor

A 15" touchscreen monitor is available from Branson. This touchscreen monitor can be connected directly to the power supply. Contact your Branson sales representative for purchasing information (see [1.4 How to Contact Branson](#)).

6.4 Front Panel Controls

You use the color touch screen on the front panel of the 2000X Power Supply to navigate through all of the menus, set welding values, view alarms, and print reports or information about the most recently completed weld.

You press the Reset Button when you encounter an alarm condition requiring that you reset the Power Supply before performing another operation.

You press the Test Button to verify the integrity of the system setup. If the power supply displays an alarm, find and address the alarm message definition in the Maintenance section of [Chapter 7: Maintenance](#) of this manual.

| WARNING | |
|---|---|
|  | <p>Do not go to Control Panel to change screen resolution as the resolution is fixed and changing it will make screen unreadable.</p> |

6.4.1 Front Panel Color Touchscreen

| CAUTION | |
|---|---|
|  | <p>Do not use excessive force or a sharply pointed object to operate the Touchscreen.</p> |

You can perform the following navigational and operational functions on the Power Supply front panel touchscreen:

- Touching the Weld Results Button will display the Weld Results from those 4 parameters from the last 7 weld cycles to be monitored from the Weld Results screen.
- Touching the Main Menu Button will display the Main Menu screen which accesses the System Information, System Configuration, Calibration, Diagnostics, Print Menu, Print Now, Save/Recall Presets, Horn Down, Screen Setup, View Current Setup, Weld Setup, Sequencing Presets, Windows Setup, Weld History.
- Touching the Weld Setup Button will display the Weld Setup screen which accesses the Weld Mode, and all Weld Parameters including the Limits menu buttons.
- Touching the Graphs Button will display the Power, Collapse Distance, Force, Amplitude, and Frequency menu buttons.
- Each of the preceding accessible buttons will provide the user with the appropriate navigation, parameter and choice options to control the operation of the power supply.

6.4.2 Power-Up and Navigation of the 2000X Power Supply

Figure 6.10 Front Panel of the 2000X Power Supply

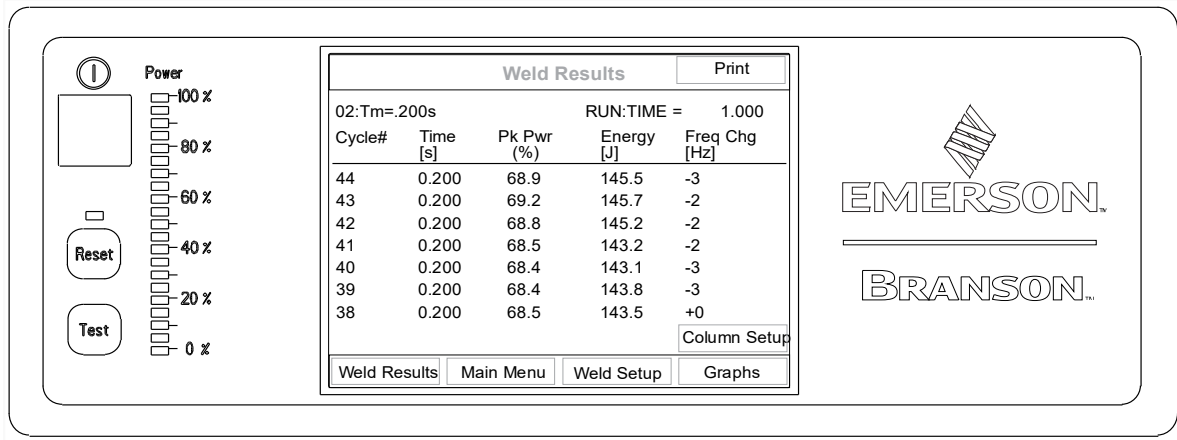

When powered up, the 2000X displays the BIOS start up screen for approximately 10 seconds before the Branson 2000X logo appears. A progress bar at the bottom of this screen shows the progress of the SBC configuration software loading. This finishes in about 25 seconds, and the screen goes blank for an additional 12 seconds while Windows OS is loading.

Once the Windows OS is loaded, the screen will display the Language Selection screen for 10 seconds. On this screen you may choose the language you wish to see on the 2000X power supply menus. Touching the exit button, or allowing the 10 second timer to expire will cause the software to load the last used language.

| NOTICE | |
|---|--|
|  | The language displayed on the 2000X power supply menus can only be changed at startup. |

Located at the bottom of the Weld Results Screen are the touch screen "buttons" that allow for the navigation and operation of the power supply. They are:

- Weld Results
- Weld Setup
- Main Menu
- Graphs

| NOTICE | |
|---|--|
|  | You can return to any of these menus at any time by pressing the respective touch screen button. |

6.4.2.1 Button Types

There are 3 types of "buttons".

- Navigation button: touching this button will "depress" it and display a new Screen.
- Toggle Parameter button: touching the button will change state, i.e. On/Off, +/-.
- Choice Parameter button: generates a pop-up with all choices shown as buttons.

6.4.3 Weld Results screen

This screen displays Weld Results from memory of the last 7 weld cycles on the Weld Results Screen.

(Results from the last 50 cycles are stored in memory, and can be printed out, but only the last 7 can be displayed on this screen.) Up to 4 parameters can be selected from the Column Setup Menu which is located in System Configuration and can be directly accessed by pressing the Column Setup button on the lower right side of the Weld Results screen. Those selected will then viewed as Weld Results. Weld Results can also be stored in a USB stick, via the USB port and be viewed in Weld History accessed from the Main Menu. This allows you to establish a much larger database to access. When the USB is installed, it can store and retrieve data that is only limited by the size of the USB memory. This expanded data is accessed as you would on a spreadsheet, by pressing the respective up, down, left, and right carets to view the entire stored contents.

| NOTICE | |
|---|---|
|  | <p>You can return to any of these menus at any time by pressing the respective touch screen button.</p> |

6.4.4 Main Menu Screen

Touching the Main Menu button displays the Main Menu screens.

The following choices are available on the Main Menu Screen:

- System Information
- Calibration
- Print Now
- Horn Down
- System Configuration
- Diagnostics
- Sequencing Presets
- Weld History
- View Current Setup
- Weld Setup
- Print Menu
- Save/Recall Presets
- Screen Setup

6.4.5 Weld Setup Menu Screen

The following is a list of the Navigation buttons that are available on the Weld Setup Menu Screen. There are 8 choices on the first of two screens, 6 on the third screen. Touching a Navigation button will move you to a Choice Parameter button. This will bring you to the Keypad Pop-up, where min/max parameter values are displayed and actual values are entered.

- Weld Mode, select from Time, Energy, Peak Power, Collapse, Absolute or Ground Detect.
- Weld Energy, 1.0 to 99,000 joules, depending on power supply.
- Hold Time, 0.010 to 30.000 seconds.
- Trigger Force, range dependent on cylinder size, see tables below. Actual range of Trigger Force values can only be attained with maximum pressure.

Table 6.1 Trigger Force Range @ Max System Pressure

| Cylinder Size | Max Pressure (MPa) | Trigger Force Range (N) | | Max Pressure (psi) | Trigger Force Range (lbs) | |
|---------------|--------------------|-------------------------|------|--------------------|---------------------------|------|
| | | Min | Max | | Min | Max |
| 1.5" | 0.69 | 22 | 707 | 100 | 5 | 159 |
| 40 mm | | 22 | 778 | | 5 | 175 |
| 50 mm | | 22 | 1219 | | 5 | 274 |
| 2.0" | | 22 | 1254 | | 5 | 282 |
| 63 mm | | 44 | 1953 | | 10 | 439 |
| 2.5" | | 44 | 1966 | | 10 | 442 |
| 3.0" | | 44 | 2829 | | 10 | 636 |
| 80 mm | | 44 | 3118 | | 10 | 701 |
| 3.25" | | 44 | 3225 | | 10 | 725 |
| 4.0" | | 44 | 5560 | | 10 | 1250 |

Table 6.2 Trigger Force Range @ Max System Pressure 20MA

| Cylinder Size | Max Pressure (MPa) | Trigger Force Range (N) | | Max Pressure (psi) | Trigger Force Range (lbs) | |
|---------------|--------------------|-------------------------|------|--------------------|---------------------------|------|
| | | Min | Max | | Min | Max |
| 63 mm | 0.6 | 150 | 1850 | 87 | 35 | 420 |
| 80 mm | | 250 | 3000 | | 60 | 680 |
| 100 mm | | 400 | 4200 | | 90 | 1060 |

Table 6.3 Trigger Force Range @ Max System Pressure 20DP

| Cylinder Size | Max Pressure (MPa) | Trigger Force Range (N) | | Max Pressure (psi) | Trigger Force Range (lbs) | |
|---------------|--------------------|-------------------------|------|--------------------|---------------------------|------|
| | | Min | Max | | Min | Max |
| 125 mm | 0.6 | 600 | 6100 | 87 | 140 | 1650 |

- External U/S Delay = On or Off. If turned on, go first to Sys Config> User I/O and select any available J3 INPUT pin, and then select Ext U/S Delay from the list of available Inputs.
 - Amplitude (step), 10 to 100%*
 - Amplitude =Fixed or Step*
 - Pretrigger, Off/On @ Distance 0.1250 to 4.0000 in, Amplitude 10 to 100%*
 - Power Match Curve, ON/OFF
 - Save/Recall Presets, save specific application parameter(s) to a preset.
 - Afterburst (AB), Off/On Delay 0.50 to 2.000, Time 0.100 to 2.000 Amplitude 10 to 100%*
 - Energy Brake> Off or On. When turned on, the power supply has some time to reduce the amplitude before the sonics are shut off. Time = 0.010 to 1.000.
 - Post Weld Seek, Off/ On Frequency Offset, Off/On, for 20 kHz +/- 400, for 30 kHz +/- 375.
 - Actuator Clear Output, Off/On, Actuator Clear Distance 0.1250 to 4.0000
 - Cycle Abort, Off/On Ground Detect Abort, Off/On Missing Part Max, Off/On Maximum 0.1250 to 4.000 in, Off/On Minimum 0.1250 to 4.000 in.
 - Timeout, 0.050 to 30.000 seconds (available in all modes excepting Time)
 - Control Limits, Off/On Peak Power Cut 1.0 to 100% (or its equivalent in watts when power units are on), AbsCut 0.1250 to 4.0000 in., ColCut 0.0004 to 1.0000 in.*
 - Suspect Limits, Reset Required, initially set to Off or On. Alarms will automatically reset (Off), or require the operator to reset (On). All available Mode Limits for -S and +S Limits are shown in [Table 6.4](#).
 - Reject Limits, Reset Required, initially set to Off or On. Alarms will automatically reset (Off), or require the operator to reset (On). All available Mode Limits for -R and +R Limits are shown in [Table 6.4](#).
 - Write In Fields, assign a unique 10 digit alphanumeric to a specific weld setup and cycle
- *µm (see [Calibration Menu](#) to set upper limit)

Table 6.4 Suspect and Reject Parameter Value Range

| Suspect (+S, -S) and Reject (+R, -R) Limits | Mode | | |
|---|---------------------|----------------------|----------------------|
| | Time | Energy | Peak Power |
| Time | | 0.010 to 30.000 sec. | 0.010 to 30.000 sec. |
| Energy | 1 to 99000 joules* | 1 to 99000 joules* | 1 to 99000 joules |
| Peak Power | 1 to 100%** | 1 to 100%** | |
| Collapse D | 0.0004 to 1.0000 in | 0.0004 to 1.0000 in | 0.0004 to 1.0000 in |
| Absolute D | 0.1250 to 4.000 in | 0.1250 to 4.000 in | 0.1250 to 4.000 in |
| Trg | 0.1250 to 4.0000 in | 0.1250 to 4.0000 in | 0.1250 to 4.0000 in |

Table 6.4 Suspect and Reject Parameter Value Range

| Suspect (+S, -S) and Reject (+R, -R) Limits | Mode | | |
|---|----------------------------|--------|------------|
| | Time | Energy | Peak Power |
| Weld Force | varies with cylinder size* | | |

* Energy varies with power supply wattage.

| Suspect (+S, -S) and Reject (+R, -R) Limits | Mode | | |
|---|----------------------------|----------------------|----------------------|
| | Collapse | Absolute | Ground Detect |
| Time | 0.010 to 30.000 sec. | 0.010 to 30.000 sec. | 0.010 to 30.000 sec. |
| Energy | 1 to 99000 joules | 1 to 99000 joules | |
| Peak Power | 1 to 100%** | 1 to 100%** | |
| Collapse D | 0.0004 to 1.0000 in | 0.0004 to 1.0000 in | |
| Absolute D | 0.1250 to 4.000 in | | 0.1250 to 4.0000 in |
| Trg | 0.1250 to 4.0000 in | 0.1250 to 4.0000 in | 0.1250 to 4.0000 in |
| Weld Force | varies with cylinder size* | | |

**The 100% Peak Power or its Upperlimit value depends on the power of the Power Supply. For example, if the power of the Power Supply is 2500 W, then the range would be 25 W to 2500 W.

6.4.6 Graphs Menu Screen

The following 6 Graphs can be displayed or printed from this menu. A "No Graph Available" will appear on the screen if no valid data is available.

- Power
- Amplitude
- Col Distance
- Frequency
- Force
- Velocity

6.4.7 Keypad Operation

There are 2 modes of keypad operation, numeric and alphanumeric. Numeric operation is typically used for all pop-ups excepting Presets and Password entry. Presets can be either, Password setup (located under System Configuration menu) is usually alphanumeric.

6.4.7.1 Numeric Keypad

The numeric entry mode displays numbers in the New Value field of the respective parameter pop-up as they are touched on the keypad.

The digits are entered from left to right. If you are to enter 10 seconds in Time Mode, touch 1, then 0, and ENT. The value displayed will then be 10.000 seconds, reflecting the resolution for the respective parameter. This will be entered in the New Value field.

In numeric keypad mode, the INC and DEC buttons become inactive when a number digit is pressed.

Once the INC or DEC buttons are pressed, the number digits are inactive. The INC and DEC will increment or decrement the Current Value field by 1 each time it is pressed.

Touching ESC will erase all digits in the New Value field. If you are using INC or DEC to change values and touch ESC, you will be able to enter digits again without changing screens.

Touching ENT will close the pop-up and return you to the Weld Setup screen.

If the value to be entered is not within the minimum / maximum range shown in the pop-up, the min/max field will indicate an error by turning red and beep.

6.4.7.2 Alphanumeric Keypad

Alphanumeric mode is essentially the same except if the same button is touched before approximately 2 seconds, the button will cycle through its available alphanumeric values. An example would be touching the STU8 button 4 times. This would cycle through S, then T, then U, then 8.

6.4.8 Testing the Welding System

After the Power Supply is installed, you can confirm that the ultrasonic welding system is operational by following this test procedure using a sample part. This assumes that the installation has been set-up and tested per [Chapter 4: Installation and Setup](#) of this manual.

To test the Welding System after installation, do the following:

Table 6.5 Testing the Welding System

| Step | Action |
|------|--|
| 1 | On the Actuator column, adjust the stroke length to 1/4 inch or more, depending on the part you will use for the test run. Position the system to allow for a minimum stroke length of 1/8 inch or more. Lock column after adjusting. |
| 2 | Position the part in the tooling. |
| 3 | Verify that factory air supply has been connected to the actuator and turned on. (If using optional pneumatic dump valve, ensure it is turned on.) |
| 4 | On the Power Supply front panel, press the power switch. The power light on the front of the Actuator becomes illuminated. |
| 5 | The power supply will go through its normal turn on sequence. At the end of this sequence the Main Menu screen is displayed*. If the power supply displays an alarm message, find the alarm message definition, cause, and correction in Chapter 7: Maintenance of this manual. If the alarm message is Recalibrate Actuator, return to Chapter 4: Installation and Setup , and re-run the procedure in 4.11 Testing the Installation . |
| 6 | On the Power Supply touch screen, press the Weld Setup button. Press the Trigger Force button. Set Trigger Force to 10 lbs. |
| 7 | On the Power Supply touch screen, press the Weld Results key. |
| 8 | Activate both Start Switches simultaneously, or activate your Start Signal if you are using the system in automation. |

Table 6.5 Testing the Welding System

| Step | Action |
|------|---|
| 9 | <p>When the weld cycle is complete, and if the cycle has completed successfully, the cycle counter increments to show a completed cycle.</p> <p>If the Reset LED on the Power Supply front panel flashes and the second line displays an alarm message, the test did not complete successfully. See Section 7.4 Troubleshooting, for information on alarm conditions and how to correct them.</p> |

*The default screen is Main Menu on V11. The Weld Results screen can also be chosen as the startup screen on the System Configuration Menu.

| NOTICE | |
|---|---|
|  | <p>If you power up and the actuator is not home, you will get two alarms. One is the Recal Actuator Alarm. Restore air to the system and power up again and a recal will not be needed.</p> |

6.5 System Menus

| NOTICE | |
|---|---|
|  | <p>Screen color presets can be modified from the Color Setup Screen. See Section 6.6.1 System Configuration Menu.</p> |

6.5.1 Using the Weld Results screen

Initially, Weld Results is the first screen to be displayed upon powering up the 2000X. The screen will show up to 4 preselected weld results of the last 7 weld cycles.

Figure 6.11 Typical Weld Results as displayed on the Opening Screen

| Weld Results | | | | | Print |
|---------------------|----------|------------|------------------|---------------|--------------|
| Preset0 COLD START* | | | RUN:TIME = 0.200 | | |
| Cycle# | Time [s] | Pk Pwr (%) | Energy [J] | Freq Chg [Hz] | |
| 44 | 0.200 | 68.9 | 145.5 | -3 | |
| 43 | 0.200 | 69.2 | 145.7 | -2 | |
| 42 | 0.200 | 68.8 | 145.2 | -2 | |
| 41 | 0.200 | 68.5 | 143.2 | -2 | |
| 40 | 0.200 | 68.4 | 143.1 | -3 | |
| 39 | 0.200 | 68.4 | 143.8 | -3 | |
| 38 | 0.200 | 68.5 | 143.5 | +0 | |
| | | | | | Column Setup |
| Weld Results | | Main Menu | | Weld Setup | |
| | | | | Graphs | |

6.5.1.1 Weld Results

Touching the Weld Results button will take you to a listing of the weld results of the last 7 weld cycles. Up to 4 parameters from the 3 Column Setup menu screens can be selected to be viewed in the Weld Results screen. (Refer to [Figure 6.11](#)) Column Setup is accessed by pressing the button in the lower right of the screen.

Figure 6.12 Column Setup Screens

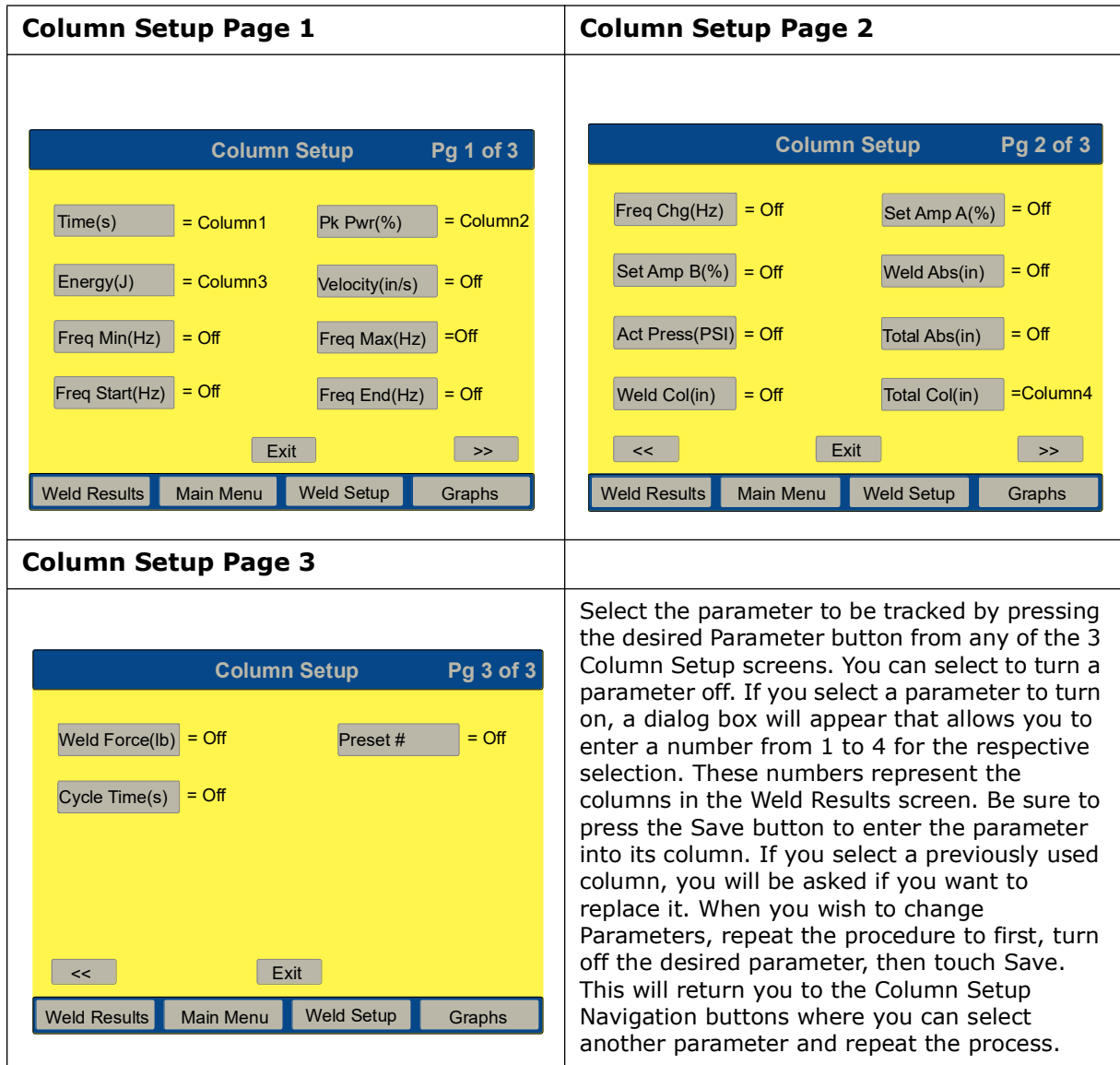

The Weld results screen also displays in the upper left corner the name of the running preset, and if an alarm has occurred, it can be observed in a red field in the most upper left of this screen.

6.5.1.2 Weld Results Parameter Definitions

- **Total Abs(in)**:** The distance from home to end of hold.
- **Weld Col (in.)**:** The distance from trigger to the end of Weld.
- **Total Col (in.)**:** The distance from trigger to the end of Hold.
- **Set Amp (%)**:** The set value for amplitude of the most recent weld when amplitude stepping is off.
- **Set Amp A (%)**:** (Does not appear when stepping is disabled.) The set value for amplitude during the first part of the weld before reaching the step point when amplitude stepping is on.
- **Set Amp B (%)**:** (Does not appear when stepping is disabled.) The set value for amplitude during the second part of the weld after reaching the step point when amplitude stepping is on.
- **Weld Force (lb)**:** The force at the end of the weld.
- **Act Press (PSI)**:** The pressure supplied to the actuator at the start of the weld.

- **Freq Min(Hz):** the minimum frequency used during the most recent weld cycle.
- **Freq Max(Hz):** the maximum frequency used during the most recent weld cycle.
- **Freq Start(Hz):** the frequency at the start of the most recent weld cycle.
- **Freq End(Hz):** the frequency at the end of the most recent weld cycle.
- **Freq Chg(Hz):** the change in frequency during the most recent weld cycle.
- **Cycle Time(s):** the time from palm button activation to "ready".
- **Preset #:** the preset number ascribed to a specific parameter.

*µm (see [Calibration Menu](#) to set upper limit)

**Can also be used with metric system

6.5.1.3 Using the Test Feature

You can use the Test key on the Power Supply to view the status of a test cycle. You can view information on the power and frequency of the test cycle and change the amplitude directly to determine its impact on the other settings through a test cycle.

Figure 6.13 Test Screen

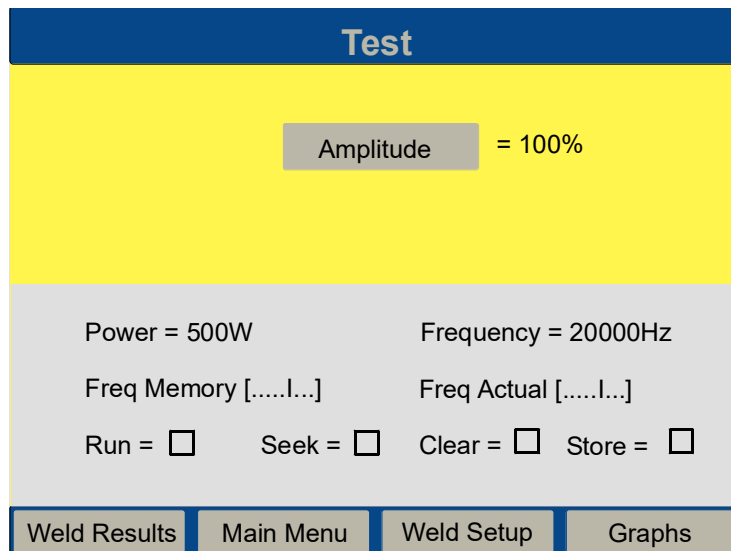

6.5.1.4 Screen Setup

| NOTICE | |
|---|---|
|  | <p>Use this feature if you find a need to re calibrate the touch areas for the buttons on the screen.</p> |

Screen Setup allows you to:

- Calibrate screen touch position and select personal colors for the screen elements.
- To calibrate screen touch position, press and release the button marked 1. If it changes to green, the first part of the calibration is successful. Then press and release button 2 to complete the recalibration of the screen. It will also indicate a successful procedure by changing to green. If either button does not result in a change to green, repeat procedure.

6.6 Using the Main Menu

| NOTICE | |
|---|---|
|  | <p>Screen color presets can be modified from the Color Setup Screen. See Section 6.6.1 System Configuration Menu.</p> |

6.6.1 System Configuration Menu

You use the System Configuration Menu to set the units in which the Power Supply will operate (that is, Metric or USCS), select amplitude units ($\mu\text{m}/\%$) and power units (W/ $\%$), enter a password, reset counters or alarms, set the date or time, turn beeper controls on or off, and perform other system-related changes. The following Figure displays the menu navigation buttons on the System Configuration screens.

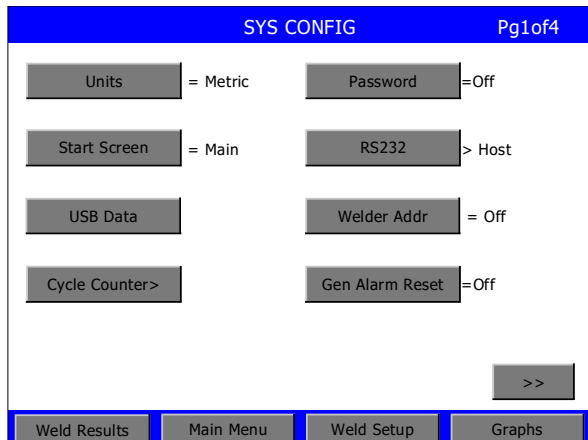
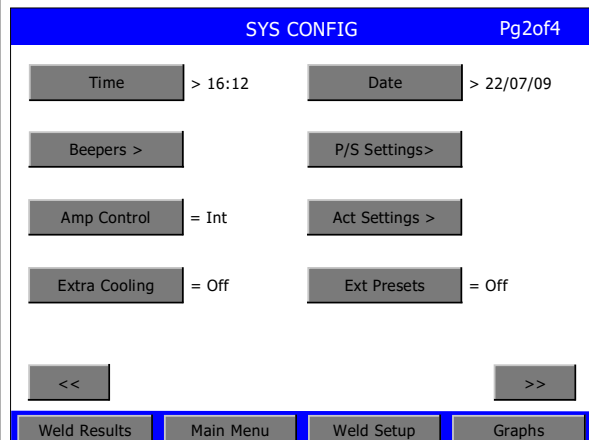
| System Configuration Navigation Menu, Pg 1 | System Configuration Navigation Menu, Pg 2 |
|---|--|
|  |  |

| NOTICE | |
|---|---|
|  | <p>If you set the Amplitude Control to External, you must connect an external voltage-scaling device to the I/O connector. If nothing is connected, only 50% amplitude will be reached.</p> |

System Configuration Navigation Menu, Pg 3

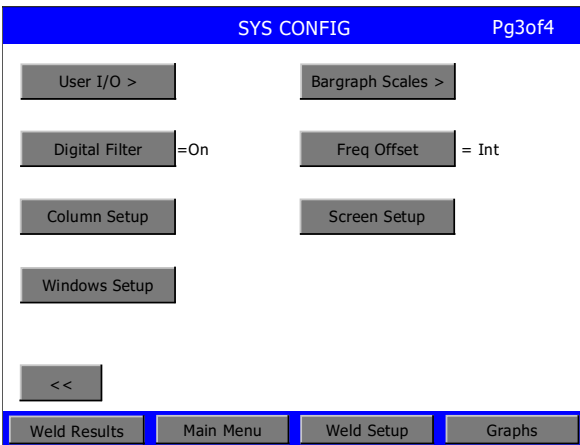

System Configuration Navigation Menu, Pg 4

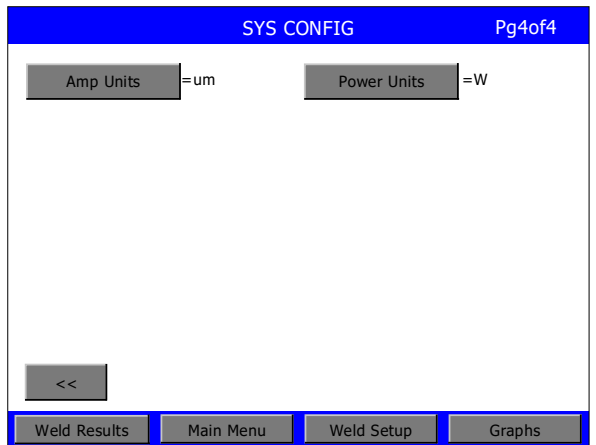

System Configuration Password Screen

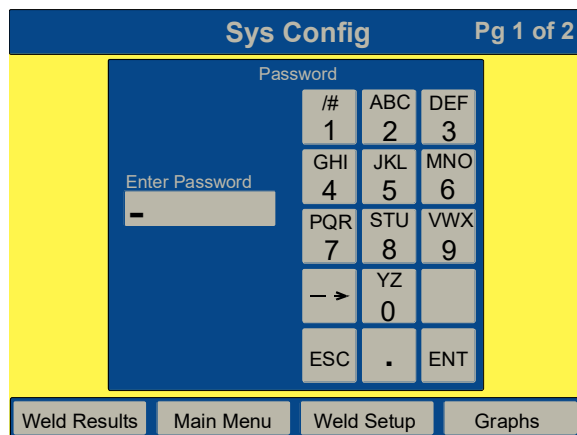

- The Password can be entered to limit access to the System Configuration Menu, weld setup, or recalling a preset. Enter Password and touch ENT.

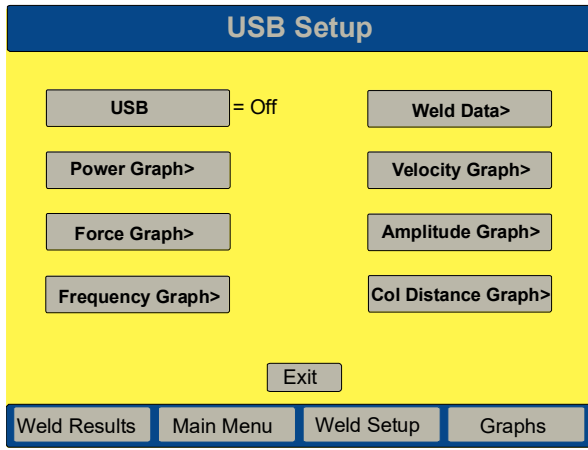
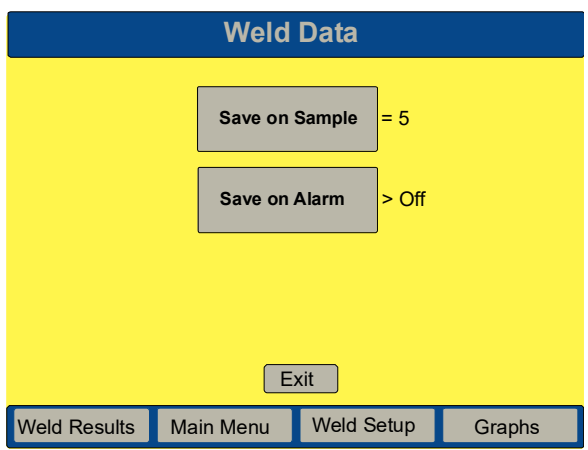
| | |
|--|--|
| <p>System Configuration > USB Setup Screen</p>  <ul style="list-style-type: none"> Select which data will be saved at the end of weld. | <p>System Configuration > Weld Data Screen</p>  <p>All data from the USB submenus shall appear as such except for the title.</p> |
|--|--|

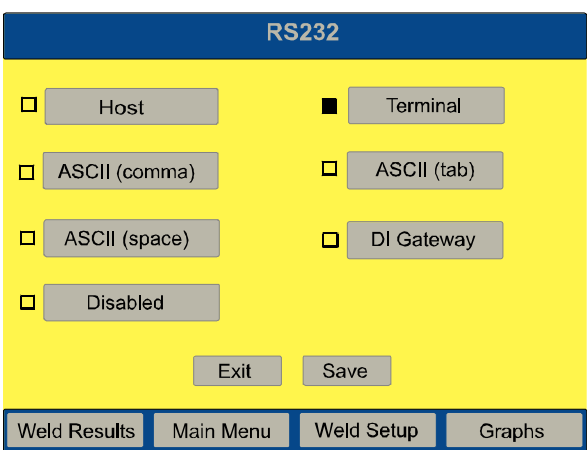
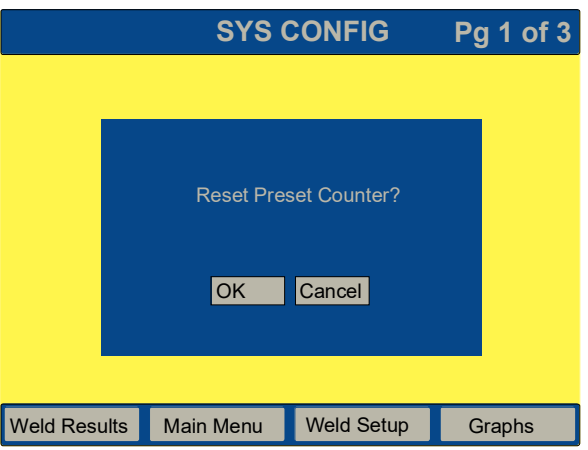
| | |
|---|---|
| <p>System Configuration RS-232c Screen</p>  | <p>System Configuration Reset > Preset Counter</p>  <ul style="list-style-type: none"> Option to reset Weld Counter. |
|---|---|

An ASCII string of weld data is sent out through the RS-232c port after each weld. The data is separated with the user-selected choice of a space, comma or tab. The end of the string contains both a carriage return and a line feed. The data contained within the string is dependent on the control level and actuator type. It is the same data that is printed on the single line data output to the printer. It is also formatted in the correct units. The data can be read either by a PC or PLC and then saved to a file in a format (i.e. CSV) that can be read by a spreadsheet program such as Excel. Alarm information will not be sent out the RS-232c port.

Table 6.6 Code Output

| 1 | 2 | 3 | 4 | Where | Definition |
|---|---|---|---|---------|---|
| | x | x | x | eeeee@ | is energy in joules (Act. Ener) |
| | | x | x | w.wwww@ | is absolute distance at end of hold in inches or mm (Total Absolute) |
| | | x | x | z.zzzz@ | is collapse at end of weld in inches or mm (Weld Collapse) |
| | | x | x | x.xxxx@ | is collapse at end of hold in inches or mm (Total Collapse) |
| | | x | x | FFF@ | is the trigger force in pounds or Newton's (Trig. Force) |
| | | | x | AAA@ | is set weld force or force A in pounds or Newton's (Set Force A) |
| | | | x | BBB@ | is set force B in pounds or Newton's or N/A (Set Force B) |
| | | x | x | hhh@ | is the weld force in pounds or Newton's (Weld Force) |
| x | x | x | x | sfff@ | is frequency change (Hz) from start of ultrasonics to end (Freq. Chg) |
| x | x | x | x | aaa@ | is the set amplitude (or amplitude A) in percentage (Set AmpA)* |
| | x | x | x | bbb@ | is the set amplitude B in percentage or N/A (Set AmpB)* |
| | | x | x | vv.v | is the velocity in/sec or mm/sec (Act. Vel) |
| | | x | x | CRLF | is the Carriage Return, Line Feed |
| x | x | x | x | @ | is either a space, tab or comma as selected by user |
| x | x | x | x | IDID | is a 4 digit # assigned by "welder Addr" in system configuration |

| System Configuration Set Units Button | System Configuration Start Screen |
|--|--|
| *Toggle to USCS or Metric by depressing the Set Units button: %, W, or μm. See Note below. | Start Screen allows you to choose whether to start at the Main menu or Weld Results screen at startup. |

| NOTICE | |
|---|---|
|  | Select units (metric or USCS) before making selections. Rounding may cause an Invalid Preset alarm when using the minimum or maximum values, when changing units. |

| System Configuration Amplitude Control Screen | System Configuration Extra Cooling Screen |
|---|---|
| Allows you to set whether amplitude is internally (INT) or externally (EXT) controlled. | When set to On, allows cooling air to start when upper limit switch is triggered and remain on throughout the cycle. When Off, air is applied at ultrasonics application. |

System Configuration Welder Address Screen

Enter a Welder Address identification number that you want to use to identify the welder used for data collection.

System Configuration General Alarm Reset

Toggle On or Off by touching the Gen Alarm Reset button to set whether a reset is required following a general alarm condition.

System Configuration Set Time Screen

Time is set in the 24 hour format.

System Configuration Beepers Screen

NOTICE



Beepers: "Trigger Beeper" is replaced with "Release Beeper" for Hand Held operation only!

Hand Held

Hand Held is accessed and turned On or Off in the System Configuration menu. Hand Held will run in Time, Energy, Ground Detect and Peak Power modes. Hand Held start function can be used with a hand held unit or a "Stack" system without an actuator. The start switch must be maintained until hold time is finished. No start cable is required as only the RF and user I/O cables are used with an e-stop jumper plug (EDP No. 100- 246-1178).

| NOTICE | |
|---|--|
|  | Use with AE actuator only. HH will not be available if an aed actuator is detected at power up or after an e-stop. |

| NOTICE | |
|--|--|
|  | Once Hand Held is turned on, the power supply must be powered off and then back on. This prevents the Door/Trigger alarm from occurring. |

- The Hand Held cycle starts with a single start switch input. Either start switch is usable. The start switch must be maintained until the end of the cycle. The weld cycle includes weld time, hold time, afterburst if enabled and post weld seek if enabled. A beeper signals the end of the need for the start switches to be on.
- A single start switch is an optional start condition and is only used when the normal PB or start input is not used. However, if used the Ext Signal must be turned on in systems configuration, User I/O Inputs, and the assigned pin hard wired.

The following Table defines failures and associated alarms when start signal is lost.

Table 6.7 Failures and associated alarms when start signal is lost

| Alarm | Cause of Alarm |
|---|---|
| Trigger Lost in Weld | Start signal lost before ultrasonics ends |
| Trigger Lost in Hold | Start signal lost before Hold ends |
| No alarm, cycle stops abruptly, terminates Afterburst | Start signal lost during Afterburst |
| No alarm, cycle stops abruptly, terminates Post Weld Seek | Start signal lost during Post Weld Seek |

| NOTICE | |
|---|---|
|  | <p>The Trigger Lost in Weld, or Trigger Lost in Hold alarms will result in an aborted cycle but the weld cycle counter will still be incremented.</p> |

| NOTICE | |
|---|--|
|  | <p>If the trigger is lost during Afterburst or Post Weld Seek, no alarm will result, but the balance of the cycle will still be aborted and counted.</p> |

- Afterburst and Post Weld Seek are available, but start switch must be maintained through either of them.
- Although Pretrigger is shown in the menu, is not functional.
- All cutoffs and limits for an AE actuator are available, limited by the control level of your power supply.
- Factory default for Hand Held is off. Cold start will not affect the setting.
- The Start Switch Closed alarm has been extended to 6 seconds for all modes.
- The PB Released output should be used to signal the PLC to release the start.

System Configuration Set Date Screen

SYS CONFIG Pg 2 of 3

Date

| | | | |
|--------------------------|-----|-----|-----|
| Current Date 10/02/03 | # | ABC | DEF |
| | 1 | 2 | 3 |
| New Date MM/DD/YY | GHI | JKL | MNO |
| | 4 | 5 | 6 |
| | PQR | STU | VWX |
| | 7 | 8 | 9 |
| | + | YZ | - |
| | INC | 0 | DEC |
| | ESC | . | ENT |

System Configuration P/S Settings

P/S SETTINGS

P/S = Digital

If the digital power supply is installed, it allows Power Supply selection, (digital or analog) and configuration for the analog supply.

System Configuration Actuator Settings Screen

ACT SETTINGS

Cyl Dia Cyl Stroke

Custom> Part Contact>

Min Trigger Metric Decimals

System Config Actuator Cyl Diameter Page 1

CYL DIA Pg 1 of 2

| | |
|-----------------------------------|---|
| <input type="checkbox"/> 1.5[in] | <input type="checkbox"/> 2.0[in] |
| <input type="checkbox"/> 2.5[in] | <input checked="" type="checkbox"/> 3.0[in] |
| <input type="checkbox"/> 3.25[in] | <input type="checkbox"/> 4.0[in] |
| <input type="checkbox"/> 40[mm] | <input type="checkbox"/> 50[mm] |

Set Cylinder Diameter

| NOTICE | |
|---|--|
|  | <p>Maximum force for Trigger with a 4 inch cylinder is 1250 lbs.</p> |

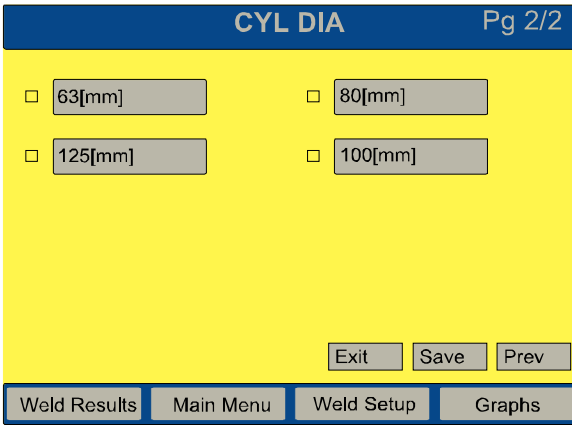
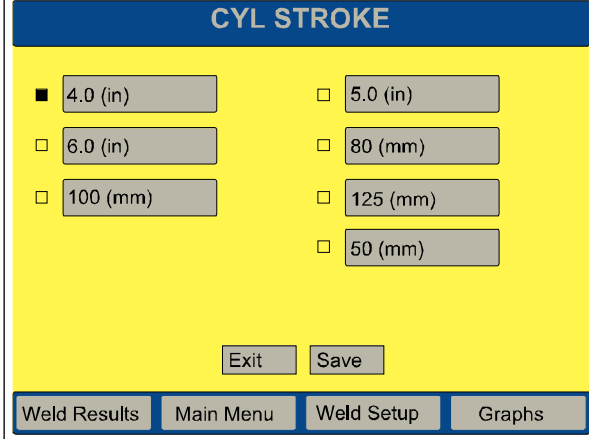
| | |
|---|---|
| <p>System Config Actuator Cyl Diameter Pg 2</p>  <p>Set Cylinder Diameter</p> | <p>System Configuration Actuator Cylinder Stroke</p>  <p>Set Cylinder Stroke</p> |
|---|---|

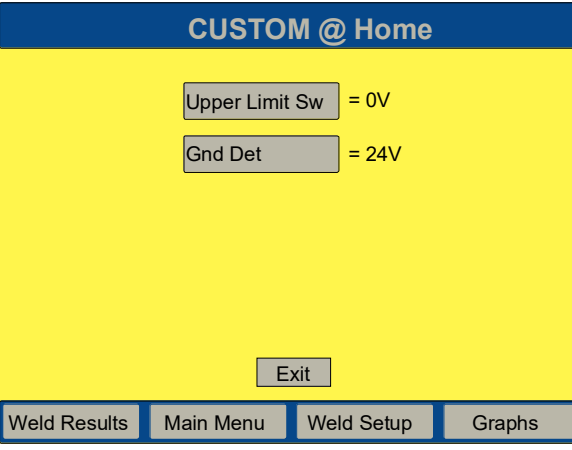
| | |
|--|--|
| <p>System Configuration Actuator Custom</p>  <p>Set to reconfigure standard I/O to use 0V or 24V levels, reassigning user I/O functions.</p> | <p>System Configuration External Presets Button</p> <p>The External Presets button allows you to toggle On or Off. When turned On, a single preset from Print on Sample, and a single preset from Print on Alarm will be used for all 16 presets.</p> |
|--|--|

External selection of presets is accessed and turned On or Off in the System Configuration menu. This feature can be used in both normal and Hand Held modes. The selection goes into effect for the next weld cycle. When enabled, inputs can be read when either start switch is received to start a new cycle. The five user inputs (J3-17, J3-19, J3-31, J3-32, J3-33) are used to decode which preset is recalled.

- When a preset is recalled externally, it will be verified if needed.
- A new alarm message has been added that will indicate that a preset has not been defined (saved) or an attempt has been made to recall a preset not available for a control level.
- External selection of presets will default to off. Cold start will not affect the setting.

Configuring the User I/O

User I/O Menu is used to configure custom actuator inputs and outputs. The User I/O menu can only be entered when the welder is not in the process of welding. If the welder is welding, the beeper will sound and entry will be denied. When entry does occur, the welder will no longer be ready, preventing welding, horn down and test. If horn down is not available, a 2-second message will be displayed indicating horn down is not available. Refer to the Branson Automation Guide (EDP [100-214-273](#)) for additional information about selection and use of Input and Output features listed in the following Table.

Table 6.8 User I/O Inputs and Outputs

| User I/O Inputs | User I/O Outputs |
|--|---|
| Disabled Select Preset * Ext U/S Delay Display Lock Ext Signal Sonics Disable Mem Reset External Start Sync Inc External Test (see RS-232c for setup) | Disabled No Cycle Alarm Cycle OK Missing Part Confirm Preset Ext Beeper O/L Alarm Modified Alarm Note External Start Sync Out |

*This option is not available at J3-1 Input.

| NOTICE | |
|---|--|
|  | If an output pin is assigned to missing part, the missing part function must first be turned on. If not, the resulting setup alarm will list Cycle Aborts and User I/O as the additional information. Either turn on missing part or turn off the output pin assigned to missing part. |

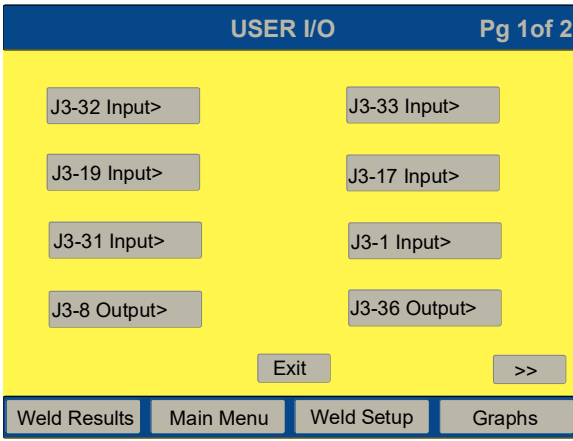
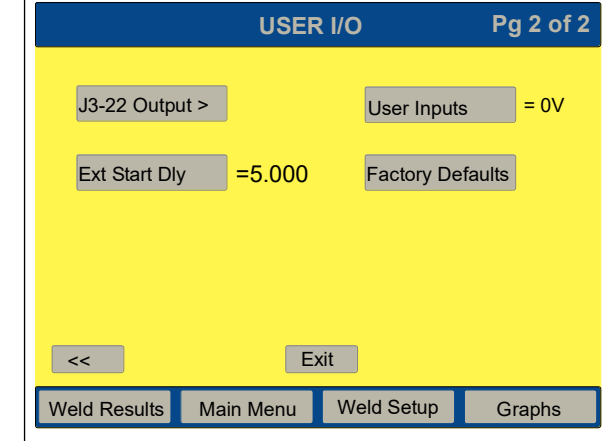
| Configuration User I/O Screen Pg 1/2 | System Configuration User I/O Screen Pg 2/2 |
|---|--|
|  |  |

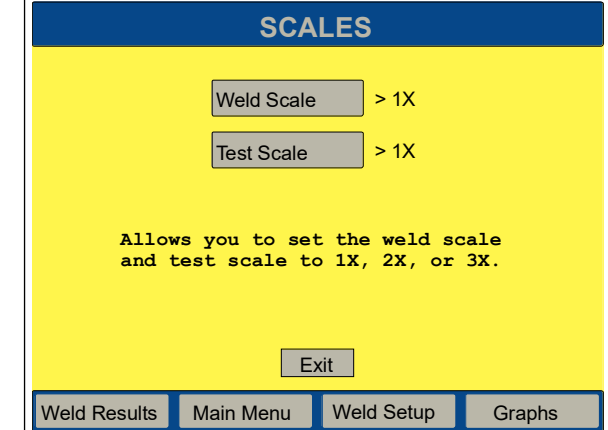
| System Configuration Digital Filter Screen | System Configuration Bargraph Scales Screen |
|---|--|
| <p>Allows you to turn the digital filter for graphing On or Off.</p> <p>NOTICE Branson recommends that you set the Digital Filter to On.</p> |  |

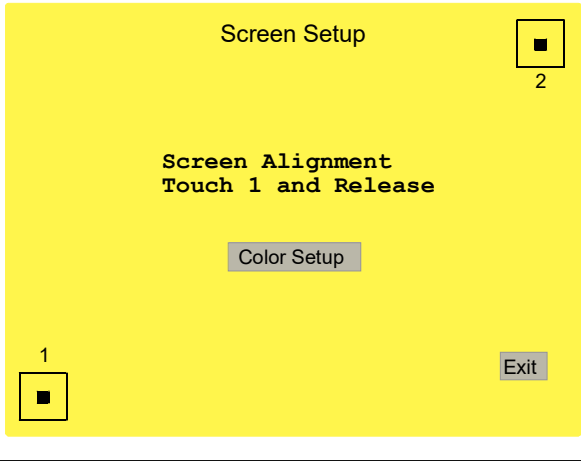
| | |
|---|---|
| <p>System Configuration Frequency Offset Screen</p> <p>Allows you to set whether the frequency offset is internally (INT) or externally (EXT) controlled (toggle).</p> | <p>System Config Screen Setup Screen Pg 1 of 2</p>  <p>Pressing the button labeled 1 will automatically align the screen. You can personalize your screen colors by pressing the Color Setup button. This will take you to the Color Setup screen.</p> |
|---|---|

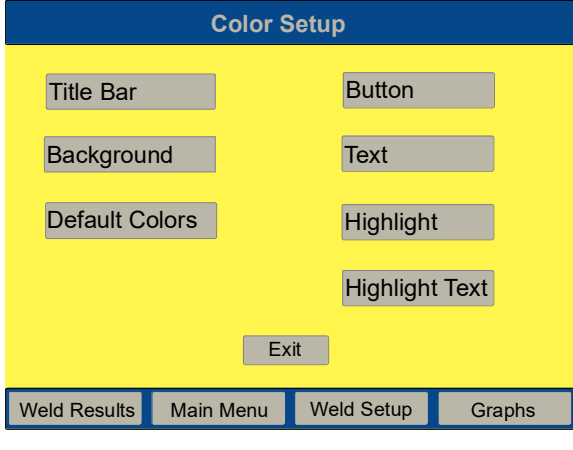
| | |
|--|---|
| <p>System Config Color Setup Screen</p>  | <p>System Config Color Setup Screen</p> <p>The Color Setup screen allows you to change colors for the Title Bar, Buttons, Background, and Text. Pressing the buttons will cycle through several colors you can select from. User can revert back to Default Colors by touching Cold Start.</p> |
|--|---|

6.6.2 System Information Screen

You can view information from the System Information screen about the current setup of your System. This screen should be available whenever you are calling Branson for troubleshooting help. Refer to the following screen.

Figure 6.14 System Information Screen

| SYSTEM INFORMATION | |
|--|----------------------|
| PS Life = XXXXXX | Overloads = 000000 |
| Gen Alarm = XXXXXX | XXkHzXXXXW |
| Calibration = Factory | Date Run = XX/XX/XX |
| P/S = Digital | Actuator = XXX |
| Control Level = X | P/S S/N = Unit #X |
| Act S/N = XXXXXXXXX | Welder Addr = Off |
| Cyl Dia = 1.5(in) | Cyl Stroke = 4.0(in) |
| <div style="display: flex; justify-content: space-between; margin-top: 10px;"> View IP Address >> </div> | |
| <div style="display: flex; justify-content: space-around; margin-top: 5px;"> Weld Results Main Menu Weld Setup Graphs </div> | |

- PS Life: Counter for the lifetime number of cycles that have been processed through the power supply.
- Gen Alarm: Counter for the lifetime number of alarms that have been addressed on the power supply.
- Date Run: Displays current date.
- P/S: Either Analog or Digital (screen shown above is for Analog power supply).
- Control Level: d.
- P/S S/N: Power supply serial number AAAAACCCCC
- Cyl Dia: Refer to [Table 6.1](#), [Table 6.2](#), and [Table 6.3](#) for available cylinder diameters.
- Overloads: Counter for lifetime number of overloads encountered on the power supply.
- Calibration: Indicates either Pass, Fail, or Factory.
- Power Supply Frequency and Power in Watts.
- Actuator: Displays aed/aod, and ae/HH, depending on configuration options for d actuators.
- S/W Version: Displays power supply software version number.
- Welder Addr: Turn on to assign a unique trackable number to a welder for data collection.
- Act S/N: Displays 9 digit Actuator serial number.
- Cyl Stroke: The maximum cylinder stroke for all standard diameter cylinders is displayed (4.0 in).
- SBC Version: Displays the software version of the Single Board Computer that controls the display.
- View IP Address.

6.6.3 Diagnostics Menu

You can use the Diagnostics Menu to perform a cold start, set the start frequency of your stack, and diagnose your system. The following page contains a map of the menu options available to you on the Diagnostics Menu. For more information on performing a cold start, see Section [7.6.3 Cold Start Procedures](#). For more information on setting up and testing your system, see Section [4.11 Testing the Installation](#).

Figure 6.15 Diagnostics Screen

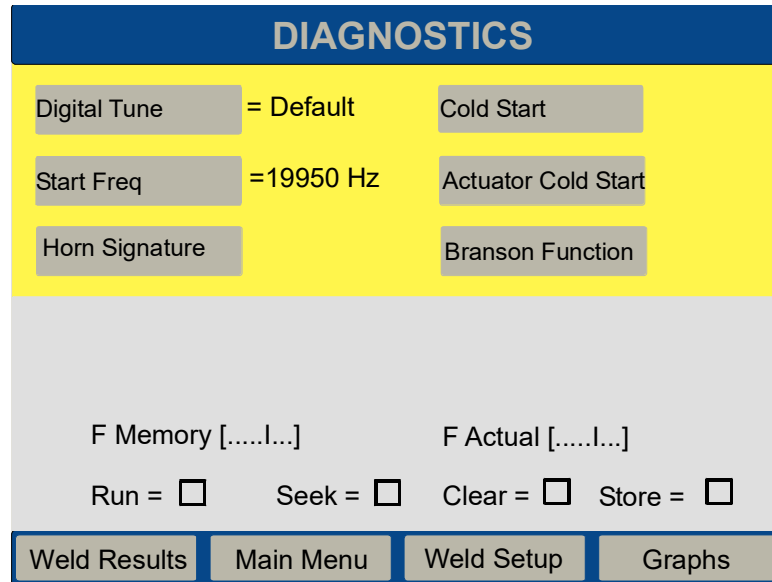



The Diagnostics Screen is divided into 2 sections, upper and lower. The upper section consists of diagnostic parameters and is refreshed when an operator selects a button. The lower section is refreshed every 250 ms.

| NOTICE | |
|---|--|
|  | <p>The "Branson Function" button shall only appear after a hidden code is entered enabling one of the functions in the menu.</p> |

Upper Section

- Touching the Start Freq button moves you to a keyboard pop-up to set the Start Frequency. As with all pop-ups, the limits are displayed, and it is not possible to enter a value out of the operating range.
- Touching the Horn Signature, button opens the following screen.
- Touching the Cold Start button on the Diagnostics screen opens the Cold Start screen.

| NOTICE | |
|---|--|
|  | <p>A cold start may take between 6 seconds and 1 minute depending on when it is done and what actuator and control level is connected.</p> |

| NOTICE | |
|---|--|
|  | <p>Using the Cold Start procedures will erase your current setup and some of the Setup parameters in the System Configuration menu. Be sure you have a record of your setup if you want to retain it. Your settings can be printed if you use the optional printer or you can save them to a preset.</p> |

- Consider your options to proceed with the Cold Start (OK) or cancel to return to your current setup. A cold start clears the Weld Setup Menu values and restores them to original factory defaults. It is not necessary to perform a cold start during normal operation and servicing, but you might find a cold start helpful when:
 - You suspect the system is not operating properly.
 - You want to make a new setup.
 - Touching Act Cold Start button on the Diagnostics screen opens the Actuator Cold Start screen.

| NOTICE | |
|---|---|
|  | <p>Using the Act Cold Start procedures will return the Spring Rate settings to factory default.</p> |

- Consider your options to proceed with the Act Cold Start (OK) or cancel to return to your current setup. A cold start clears the Spring Rate Table values stored in BBR, and restores them to original factory defaults. It is not necessary to perform an Actuator Cold Start during normal operation and servicing, but you might find a cold start helpful when you are unable to make the system calibrate properly.

Lower Section

This display is viewable during a weld cycle.

| | |
|--|--|
| <p>F Memory: This bar graph represents the stored frequency at the end of the last cycle.</p> <p>This is the frequency the power supply will start at for the next cycle.</p> | <p>SK (Seek): Indicates the power supply is running at 5% amplitude for the purpose of finding the resonant frequency of the stack.</p> |
|--|--|

| | |
|--|--|
| <p>F Actual: This bar graph represents the running (natural) frequency of the stack in real time.</p> | <p>C (Clear): Indicates there was an overload in Run or Test Mode and memory was cleared.</p> |
| <p>R (Run): Indicates that ultrasonic energy is on.</p> | <p>St (Store): Indicates the running frequency of the system is stored into memory at the end of a cycle or at the end of a seek.</p> |

6.6.3.1 Horn Signature Menu

Figure 6.16 Horn Signature screen during scan

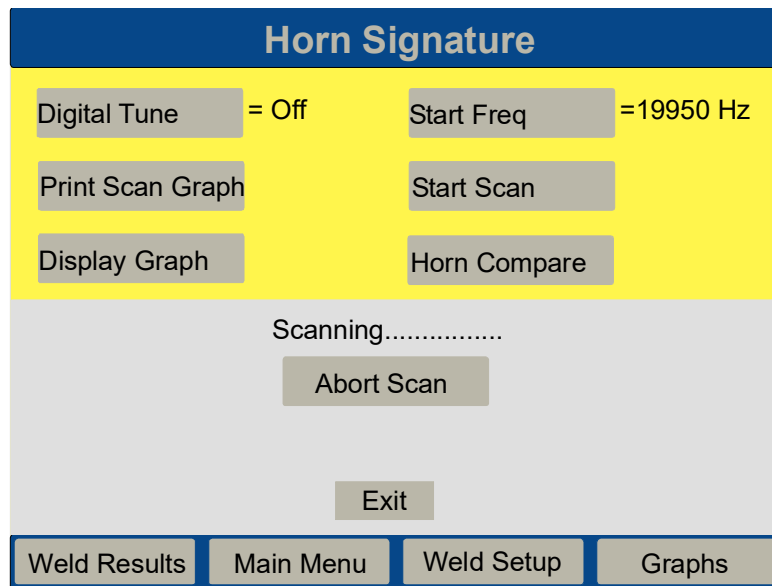
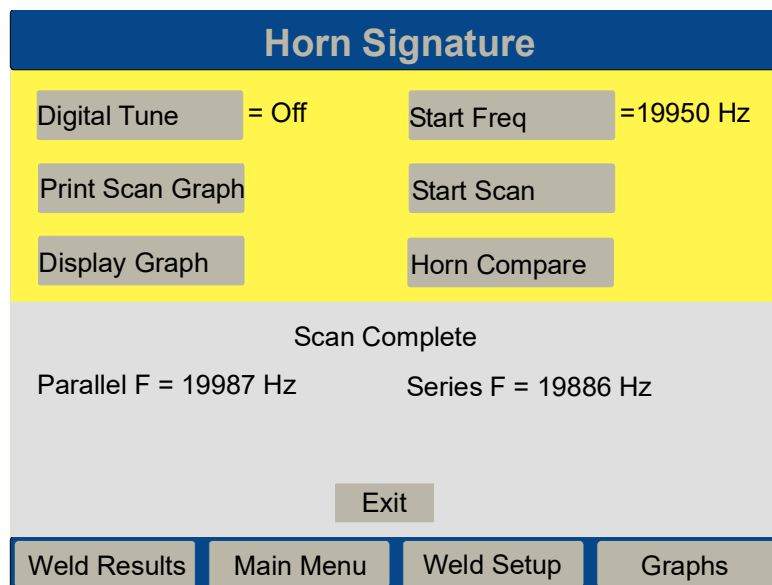

Figure 6.17 Horn Signature Screen



- Pressing Start Scan will generate a scan of horn reactance showing resonant frequencies at the zero crossover from capacitive to inductive reactance. Ideally there will be only one resonant frequency. The screen will display the text "Scanning..." with the rate of update for every dot being 1/4 second.

- The abort scan button appears up to 6 frequencies. Each frequency will be labeled as Series or Parallel. You can view a graph of these reactance values by pressing Display Graph.
- If you are connected to a Printer, you can press Print Graph, and up to six resonant frequencies within a window of +/- 2 1/2% of the center frequency will be displayed as they cross zero.
- Touching the "Digital Tune" button performs the same function as the Button on the Diagnostics Menu labeled "Start Freq". Touching the Digital Tune button will toggle between On and Default. This must be set to On in order to set Start Frequency.

| NOTICE | |
|---|--|
|  | <p>Do not use this feature unless advised to do so by Branson. It is not required for most applications.</p> |

Figure 6.18 Compare Data Screen

| Compare Data | | | Print |
|--------------|------------|------------|------------|
| | Scan A | Scan B | Scan C |
| Horn ID | Horn11808 | Horn12098 | Horn12043 |
| Time | 10:30:05 | 11:48:45 | 12:35:00 |
| Date | 11/10/2004 | 11/10/2004 | 11/10/2004 |
| Freq 1 | 19865 (S) | 19877 (S) | 19888 (S) |
| Freq 2 | 19939 (P) | 19936 (P) | 19940 (P) |
| Freq 3 | 20037 (S) | 20056 (S) | |
| Freq 4 | 20139 (P) | 20180 (P) | |
| Freq 5 | 20232 (S) | 20274 (S) | |
| Freq 6 | 20388 (P) | 20399 (P) | |
| Exit | | | |
| Weld Results | Main Menu | Weld Setup | Graphs |

The parallel frequency highlighted in blue is the frequency the Digital Tune is set at.

6.6.4 Horn Down

You can use the Horn Down Navigation button to verify that your fixture is properly set up or to determine the absolute distance that the horn needs to travel to weld your parts. After pressing the Horn Down button you can press the Start Switches, or you can use manual override to bring the horn down to the position you have set without ultrasonic energy on by using the mechanical stop. Once the horn is in position, you can release the Start Switches in order to verify your setup.

Each time you enter the Horn Down menu, the weld force and downspeed settings are transferred from the weld setup.

Figure 6.19 Horn Down Screen

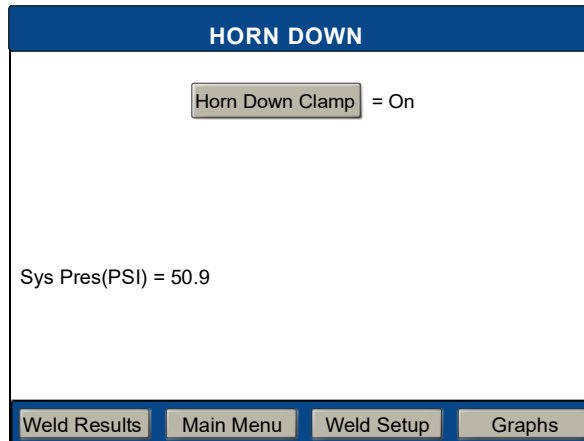

To proceed, select Horn Down Clamp On or Off at the top of the screen.

- Turning the Horn Clamp On will cause the horn to remain at the workpiece when the Start Switches are released, until it is released by touching the Weld Results Button. Pressing Retract will bring the horn up, and you will remain in the Horn Down screen.
- With Horn Clamp Off, the horn will only stay down as long as the Start Switches are held on.

In either the Horn Down On or Off, you will be able to read at the bottom of the screen:

- System Pressure,
- the distance the horn traveled (Absolute Distance) and
- the Velocity of the horn at part contact.
- Force on the part.

You can also disconnect air and manually bring the horn down to read distance and align your fixture.

- To use the Horn Down feature manually without Start switches, press the manual override on the solenoid valve which is accessible through the hole in the top of the Actuator, or disconnect air to the system and manually lower the horn.

| NOTICE | |
|---|---|
|  | <p>On an AE actuator, only the Horn Down Clamp button is shown.</p> |

| WARNING | |
|---|--|
|  | <p>Before using Manual override, make sure all hands are clear of the Horn and base surface.</p> |

6.6.5 Save/Recall Presets

You can set up the 2000X Power Supply to weld a particular application and then save the settings to a preset. You can do this for up to sixteen presets.

If, for instance, you have verified through trial and error or some other means that a particular combination of Power Supply settings yields acceptable parts for each of several different configurations or materials, you might want to save that combination of settings as a preset to streamline the change from production of one part to another. Always set the Power Supply to the combination of parameter settings that you want to save before entering the Presets menu.

Touching the Presets button will display the Save, Recall, Clear and Verify Screen as shown below.

Figure 6.20 Save/Recall Presets Screen

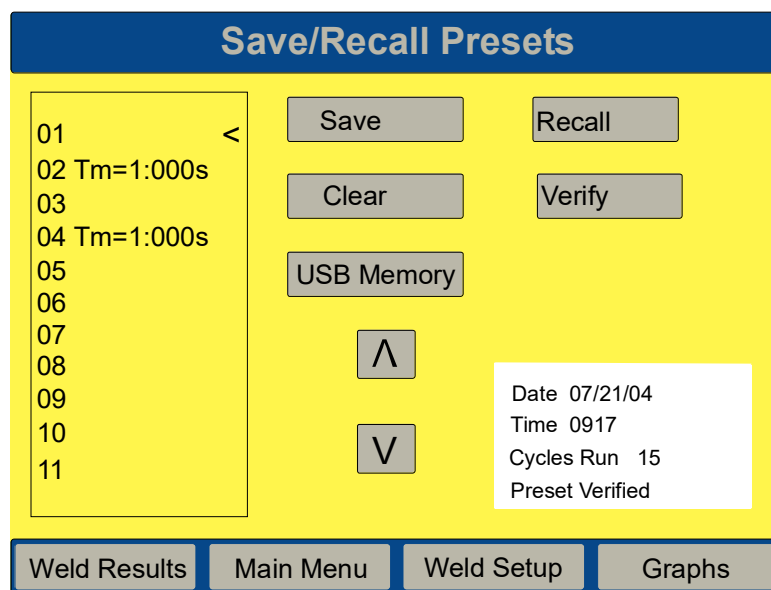

| NOTICE | |
|---|---|
|  | <p>USB Memory button will only show when a USB stick is inserted.</p> |

To save a Preset:

- Scroll the < at the end of the preset name to the desired Preset using the ^ and v arrow buttons.
- Touch the Save button.
- A pop-up screen then offers options to Automatically Name or Assign Name to the preset.

Figure 6.21 Save Presets Pop-up Screen

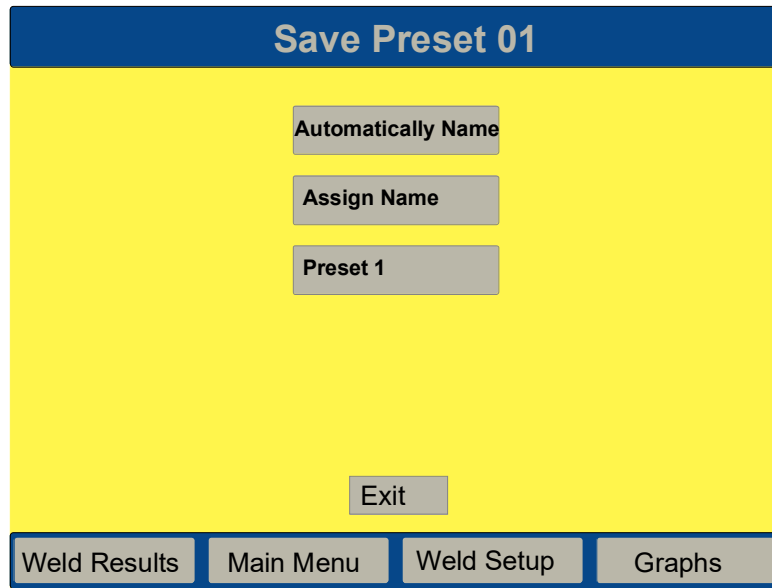

- Touching the Automatically Name button shall close the window and place the preset name in the list. If the number already had a preset name, the overwrite pop-up will be displayed.

The convention for naming presets is as follows:

Table 6.9 Preset Naming

| | |
|-----------------------|--------------------------|
| Time: Tm = xxxxS | Absolute: Ab = xxx IN |
| Energy: En = xxxxJ | Collapse: Cl = xxx IN |
| Peak Power: PP = xxx% | Ground Detect: GD = xxxS |

- When assigning a name, a keypad is displayed. Touch up to 10 alphanumeric characters, then touch ENT to close both windows and place the name in the list. If the preset number already had a name, the overwrite pop-up will be displayed. ESC can be used to erase one character at a time starting with the one last entered. Touching ESC after all characters are erased will close the window and not make any changes.
- Select this preset name to overwrite with its current name. Return to the Save/Recall Presets screen and select the preset you would like to name with your previously selected preset. Select Save and it will appear on the Save Preset screen as a button along with the other preset. Select desired preset and overwrite to assign new preset name.

Figure 6.22 Name Preset Keypad

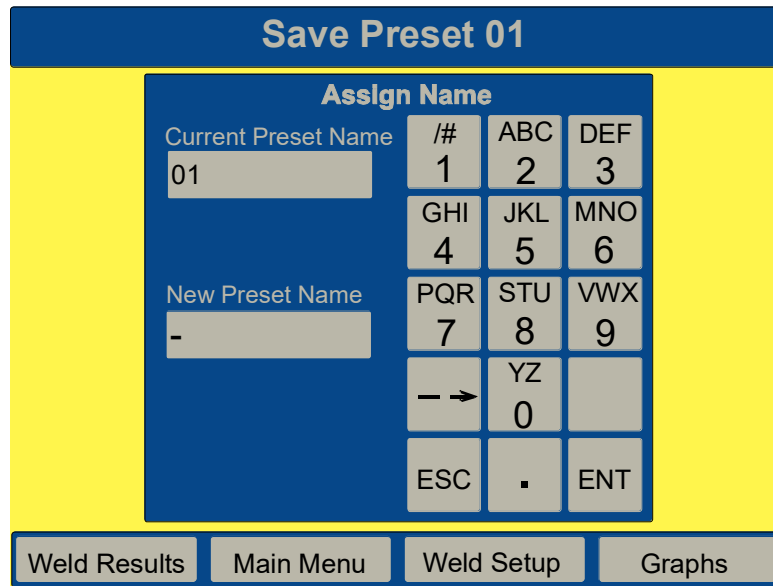

To Recall a Preset:

| NOTICE | |
|---|--|
|  | <p>A preset recall is not allowed if a cycle is in progress. Touching the Recall button while a cycle is running, shall display the following for four seconds: Please Wait for Cycle to complete or Printing to Stop.</p> |

- Scroll the < at the end of the preset name to the desired Preset using the ^ and v arrow buttons.
- Touching the Recall button while not cycling shall recall the preset. The screen shall go back to displaying the Weld Results Screen.
- The Recalled Preset will be verified (if it was not already verified) when the cycle is run.

To Clear Preset:

- Scroll the < at the end of the preset name to the desired Preset using the ^ and v arrow buttons. Touching the Clear button shall display the OK or Cancel popup.

To Verify a Preset:

When you press the Verify button, the following screen appears for 1 to 2 seconds to verify the Preset.

Figure 6.23 Verify Preset Screen

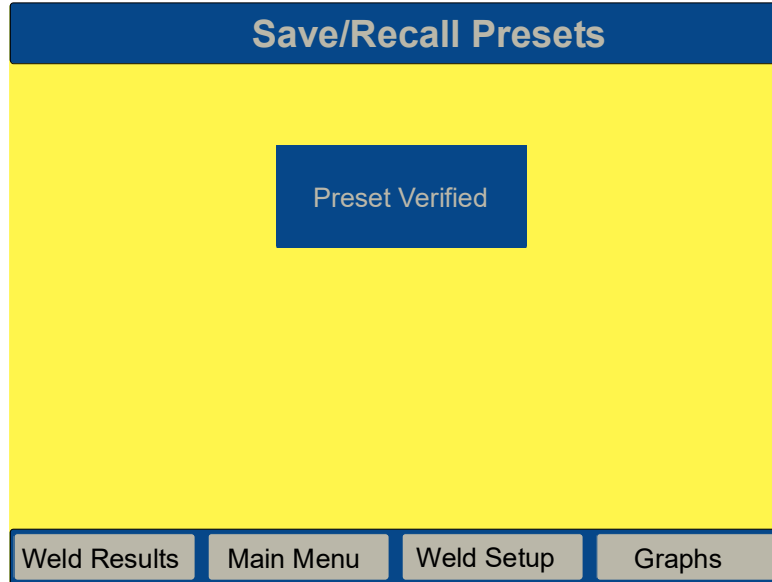

To Save a Preset to USB:

When you press the USB Memory button, the following screen appears.

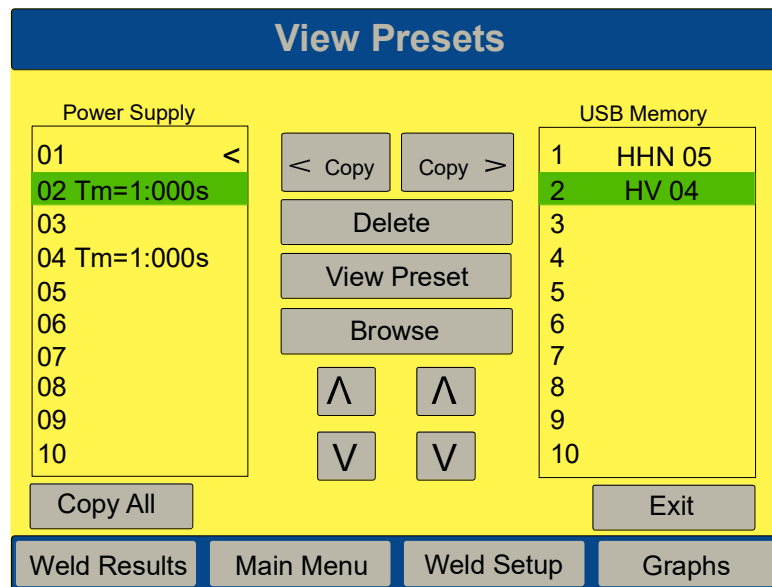

- Scroll the < at the end of the preset name to the desired Preset on either the Power Supply or USB Memory using the ^ and v arrow buttons. The preset will be highlighted in bright green.
- When you select a preset to copy from Power Supply to USB Memory, it will be added to the next available line on the USB.
- When you select a preset from USB Memory to transfer to a specific preset on the Power Supply that is already named, a pop-up will ask if you want to overwrite. You can elect to View Preset before you overwrite.

6.6.6 Sequencing Presets

The sequence is a list of preset numbers to be run in a defined order. The list contains between 2 and 30 presets. Any non-setup alarm will allow you to restart the sequence or to continue from where the alarm occurred. The power supply frequency memory may be cleared after every cycle.

| Main Menu>Sequencing Presets Screen | Main menu>Define/Edit Sequence Screen |
|-------------------------------------|---------------------------------------|
| | |

6.6.7 Weld History

Weld History shows the last 50 weld summary data lines saved.

| Main Menu > Weld History Screen | Main menu > Weld History Screen |
|---------------------------------|---------------------------------|
| | |

*USB Recall and USB Setup buttons are only available when there is a USB stick present.

6.6.8 Calibration Menu

You can use the Calibration Menu to calibrate the pressure sensor and force readout of the S-Beam load cell. The actuator calibration may be required when changing the booster, horn, or regulator pressure. You will be prompted to perform the actuator calibration the first time you power up the system, recall a preset, or any time the controls sense a significant change in the stack weight greater than five pounds. The sensor calibration is set at the factory and should be good for the life of the system. But if you are operating under regulatory requirements, calibrate the sensors according to their schedule and Branson standards.

The 100% of the Upper limit or Peak Power of the power supply depends on the model of the UPS, for example, for a 15 kHz Model the 100% is 3300 W.

For more detailed information on calibrating the sensors, you can contact Branson by calling the Technical Support as indicated on [Table 1.1 Branson Contacts](#), on Section [1.5.3 Departments to Contact](#). The Calibration Screen below shows the menu flow available to you to complete the Calibration.



| NOTICE | |
|---|--|
|  | "Cal Full System" requires critical test instruments. This should only be performed by qualified personnel. Contact your Branson representative for specific information regarding this calibration. |
| NOTICE | |
|  | The Calibration Menu can also be used to calibrate amplitude values in microns. |
| CAUTION | |
|  | Before continuing, make sure all hands are away from the Horn and base surface. The horn will accelerate rapidly to the base surface no matter which screen you are in. |

Figure 6.24 Calibration Screens



6.6.9 Print Menu

You can print information about the current welder setup, the most recent weld that you performed, or the last 50 welds (weld history) that you performed, as well as graphs of the power, amplitude, frequency, collapse distance, force, or velocity of the most recent weld, plotted against the time of the weld cycle (in seconds).

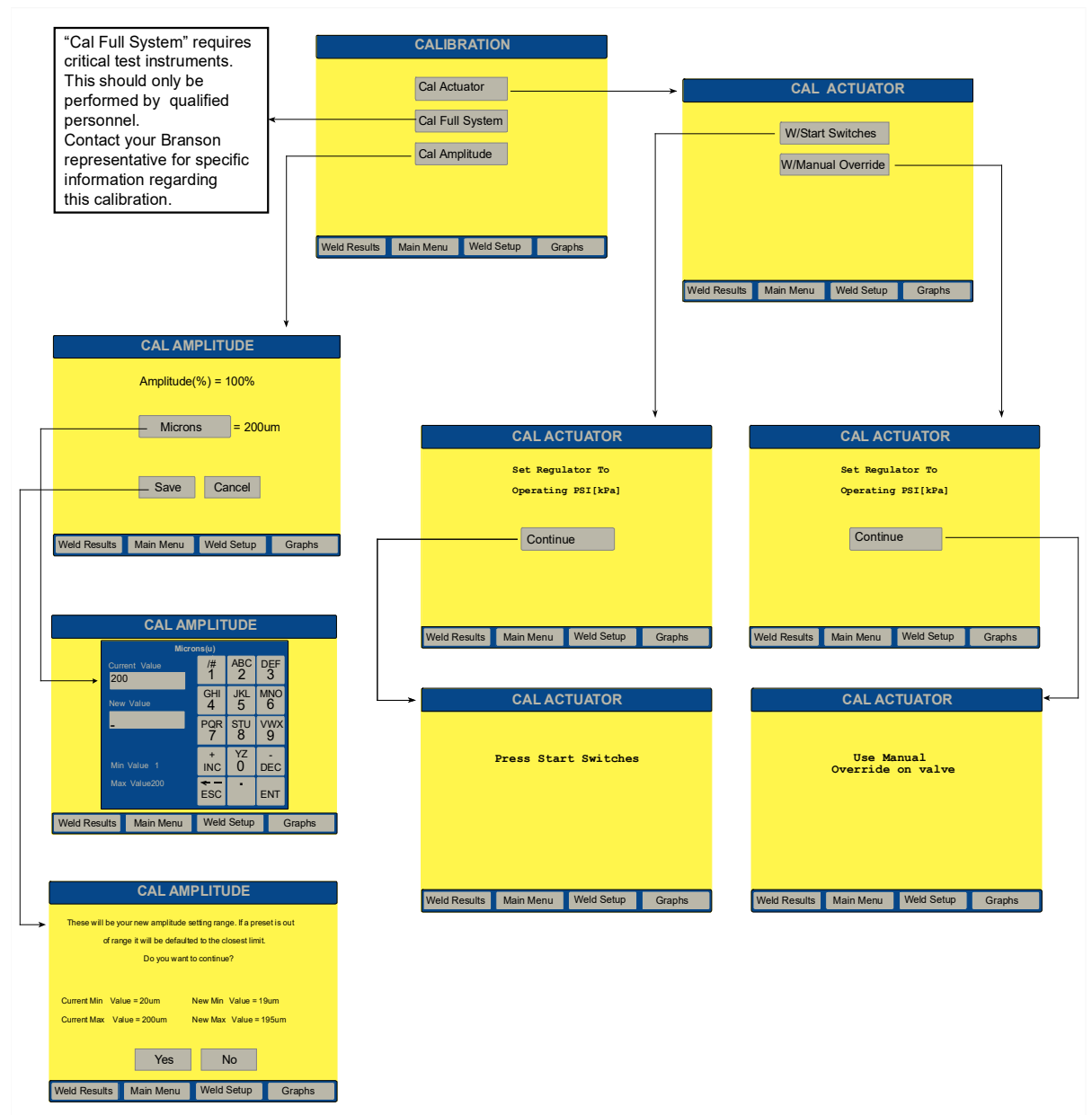
You can print on demand, sample and alarm, and mix any mode/trigger that is necessary to evaluate weld results.

Settings for scale must be set for printing anything other than time mode (which is autoscaling), and must be set before cycle is run.

You can gain access to the Print menu from the Main menu and selecting Print Menu. The following Figure displays the menu on the Print screen.

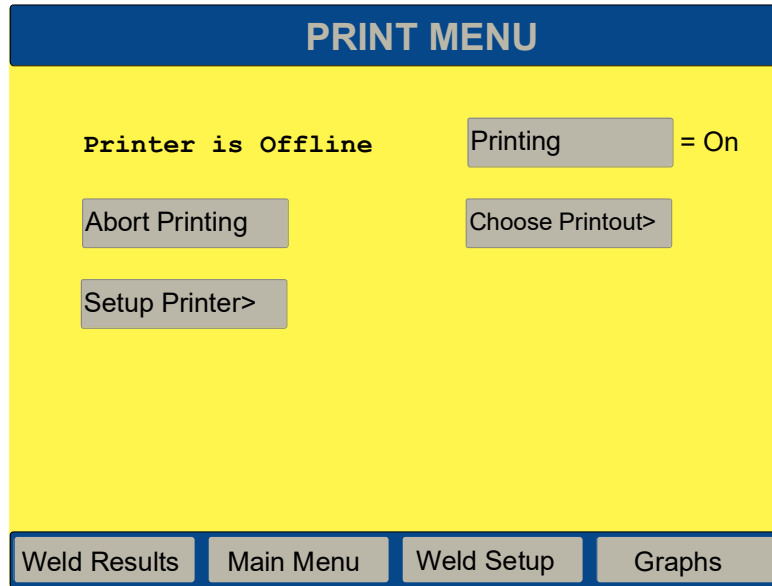

| Print / Abort Printing Navigation Screen | Print / Choose Printout Screen, 1 of 2 |
|---|---|
| | |
| <p>After this screen appears, realign the paper in the top of your printer and touch continue to return you to the Print menu.</p> | <ul style="list-style-type: none"> • Selection of any of the options for graphs or data will bring you to the (following) Setup screen. |
| <ul style="list-style-type: none"> • Select Setup to print your current weld setup. • Select Weld History to print information for up to the previous 50 welds. | <ul style="list-style-type: none"> • Select Weld Data to print a summary of information about the most recent weld. • Select Power Graph to print a graph of the percentage of Peak power that was used over time (in seconds) in the most recent weld. |

| | |
|--|---|
| <ul style="list-style-type: none"> Select Col Distance Graph to print a graph of the distance the part has collapsed over time (in seconds) in the most recent weld. | <ul style="list-style-type: none"> Select Velocity Graph to print a graph of the velocity of the horn over time from just before Trigger begins to just after the Hold ends. |
| <ul style="list-style-type: none"> Select Force Graph to print a graph of the force applied to the part over time (in seconds) in the most recent weld. | <ul style="list-style-type: none"> Select Amp Graph to print a graph of the percentage of maximum amplitude over time (in seconds) in the most recent weld. |
| <ul style="list-style-type: none"> Select Freq Graph to print a graph of the horn frequency (in kHz) over time (in seconds) in the most recent weld. | <ul style="list-style-type: none"> Select Auto Scale to toggle between ON and Off for Auto Scale. Note: Can be turned on in Time Mode only. |
| <ul style="list-style-type: none"> Select X Scale(s) to set the value for the time in seconds to which you want to scale if Auto Scale is Off. Note: Displayed only when Auto Scale is Off. | |

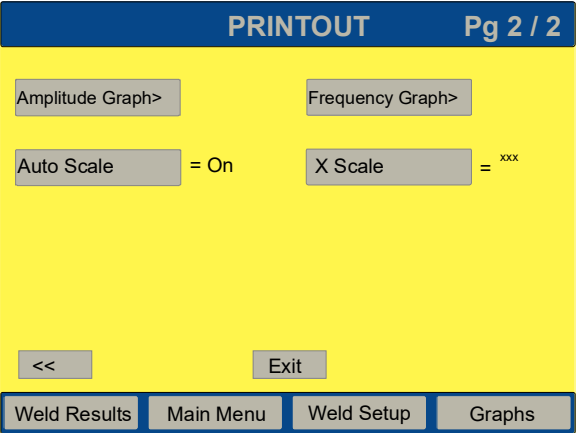
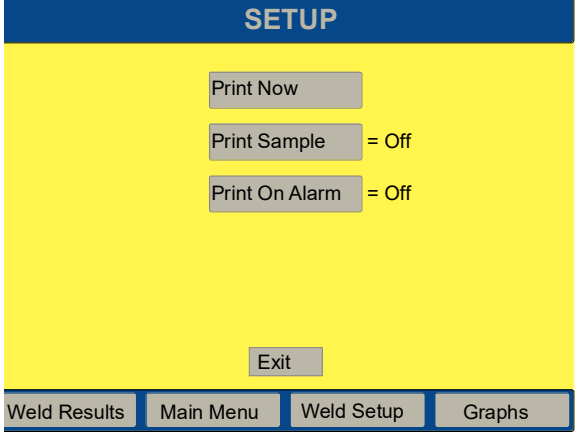
| Print / Choose Printout Screen, 2 of 2 | Print / Setup Screen |
|---|---|
|  |  |
| <p>NOTICE The X Scale button shown, will change to Auto Scale in Time mode only.</p> | <ul style="list-style-type: none"> Touching any of the Navigation buttons on the Printout screen will bring you to this screen. Print Now will present a message if no suitable printer is available for printing. Print on Sample allows you to enter the number of samples required to trigger printing and assign this number to any of the 16 presets. Print on Alarm is toggled On or Off. |

6.7 Using the Weld Setup Menu

The Weld Setup Menu allows you to select and set all the parameters necessary to successfully operate in any available mode. They are accessed on the 3 Weld Setup Screens via Navigation buttons and their subsequent pop-ups. The Weld Setup Screens are shown below.

| NOTICE | |
|---|--|
|  | <p>Screen color presets can be modified from the Color Setup Screen. See: Section 6.6.1 System Configuration Menu.</p> |

Figure 6.25 Weld Setup Screen Number 1

WELD SETUP
Pg 1 of 3

| | |
|---------------------|-------------------|
| Weld Mode > Time | Trig Force = 10lb |
| Weld Time = 0.010s | Amplitude > Fixed |
| Hold Time = 0.010s | Amplitude = 100% |
| Save/Recall Presets | Afterburst > Off |

Weld Results
Main Menu
Weld Setup
Graphs

Figure 6.26 Weld Setup Screen Number 2

WELD SETUP
Pg 2 of 3

| | |
|----------------------|-----------------------|
| Pretrigger | Pwr Match Curve = Off |
| Reject Limits = Off | Save/Recall Presets |
| Suspect Limits = Off | Energy Brake = Off |
| Post Weld Seek = Off | Control Limits = Off |

Weld Results
Main Menu
Weld Setup
Graphs

Figure 6.27 Weld Setup Screen Number 3*

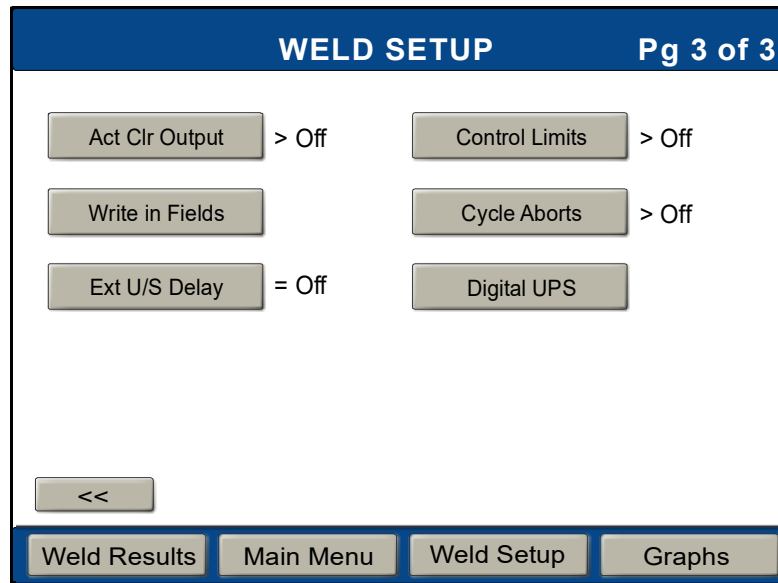

*The Act Clr Output button will only appear when there is an AED actuator connected.

6.7.1 Weld Mode Setup

After analyzing your specific application, you can determine the Weld Mode to use to weld your parts. A Weld Mode is a set of parameters that governs the weld. (Contact the Branson Ultrasonics Applications Laboratory for more information on determining the best mode for welding your application. See Section [1.4 How to Contact Branson.](#))

There are six Weld Modes to choose from Time, Energy, Peak Power, Collapse Distance, Absolute Distance, and Ground Detect Modes. The following table describes each mode:

Table 6.10 Weld Modes

| Weld Mode | Description |
|--------------------|--|
| Time | You select the length of time (in seconds) that ultrasonic energy will be transmitted to your parts. |
| Energy* | You select the amount of energy (in Joules) that will be transmitted to your parts. (A Joule is one watt per second.) |
| Peak Power* | You select the peak power level as a percentage or watts of full power at which the weld is terminated. |
| Collapse Distance* | You select the vertical distance (in inches or millimeters) that your part collapses before ultrasonics are terminated. |
| Absolute Distance* | You select the vertical distance (in inches or millimeters) that the horn travels from the home position before ultrasonics are terminated. |
| Ground Detect* | The 2000X provides ultrasonic energy until the horn comes in contact with your electrically isolated fixture or with the anvil, providing that you made an electrical connection between the actuator and your fixture or anvil. |

| NOTICE | |
|---|---|
|  | <p>*In these modes, timeout can be used for control limits.</p> |

Touching the Weld Mode navigation button will bring up the following screen from which you select the desired mode.

Figure 6.28 Weld Mode Select Screen*

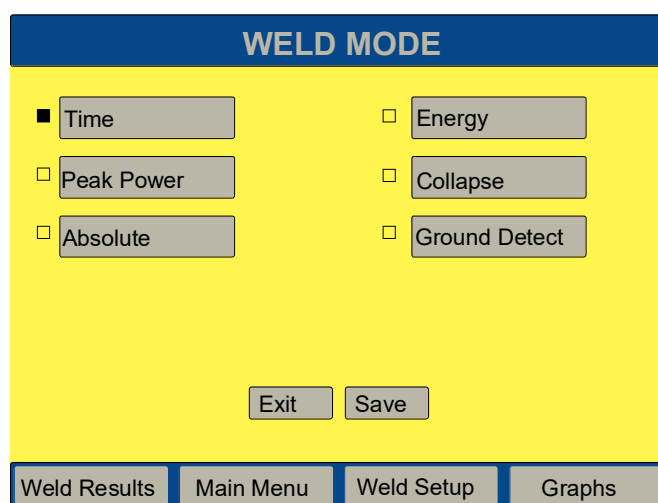

- Touch the Save button after selecting mode. This will return you to Weld Setup Screen number 1.

*The Collapse and Absolute selection buttons only appear when an AED actuator is present.

6.7.1.1 Using Time Weld Mode

You can use Time Mode to select the length of time that ultrasonic energy is applied to your parts. Within Time Mode, you can also select several other parameters, ranging from Hold Time (in seconds) to Suspect and Reject Limits. The following Table displays parameters available for use in Time Mode. The parameter input limits pop-up screen is accessed when the respective parameter Navigation button is touched. Refer to Section [6.4.5 Weld Setup Menu Screen](#) for all available parameter limits.

Figure 6.29 Time Weld Mode Setup

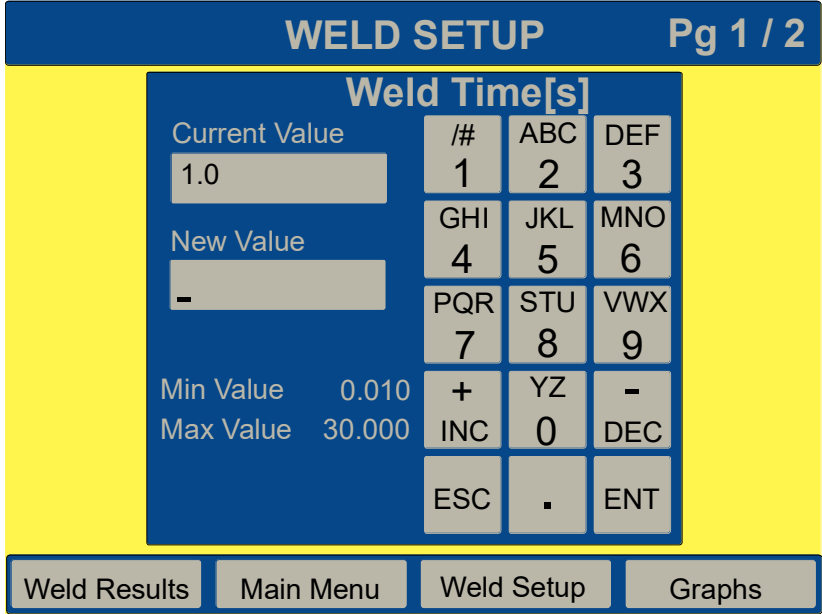
| | |
|---|---|
| Available Parameters | The Pop-up menu shown below allows you to set Time Values. Time parameter limits are displayed in the lower left field as Min and Max Value. You cannot successfully enter invalid values. Refer to Section 6.4.7 Keypad Operation for Keypad operation if necessary. |
| <p>WELD SETUP</p> <p>WELD MODE> TIME</p> <p>Weld Time(s)= 30.000</p> <p>Hold Time(s)= 30.000</p> <p>Afterburst> Off</p> <p>Trig Force(lb)=</p> <p>Amplitude> STEP</p> <p>Amplitude(%)=</p> <p>Pretrigger> Off</p> <p>Pwr Match Curve</p> <p>Save/Recall Presets</p> <p>Energy Brake</p> <p>Frequency Offset> Off</p> <p>Reject Limits > Off</p> <p>Suspect Limits > Off</p> <p>Post Weld Seek = Off</p> <p>Act Clr Output> Off</p> <p>Control Limits > Off</p> <p>Cycle Aborts> Off</p> <p>Write In Fields</p> <p>Ext U/S Delay</p> |  |

6.7.1.2 Using Energy Weld Mode

You can use Energy Mode to select the amount of ultrasonic energy that is applied to your parts. Within Energy Mode, you can also select several other parameters, ranging from Hold Time (in seconds) to Suspect and Reject Limits. The following Table displays parameters for use in Energy Mode. The parameter input limits pop-up screen is accessed when the respective parameter Navigation button is touched. Refer to Section [6.4.5 Weld Setup Menu Screen](#) for all available parameter limits.

Figure 6.30 Energy Weld Mode Setup

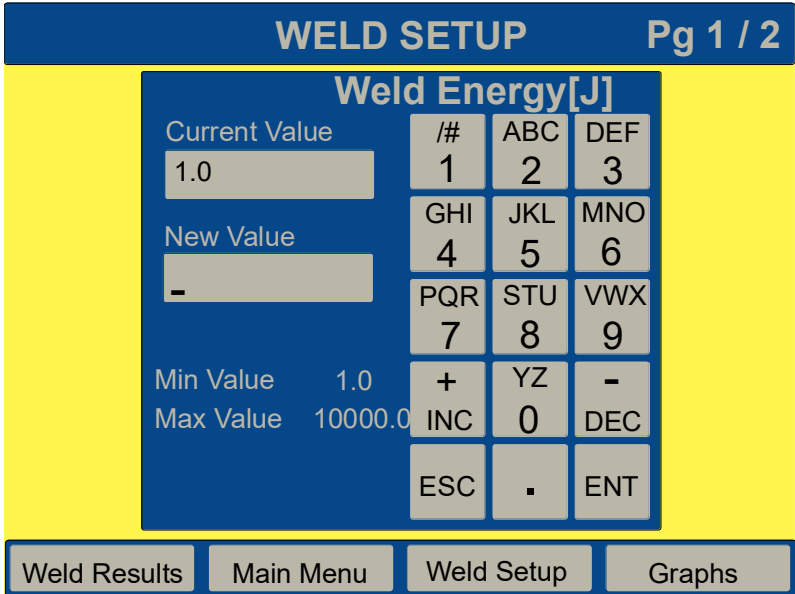
| | |
|--|--|
| <p>WELD SETUP</p> <p>Weld Mode> Energy</p> <p>Weld Energy(J)= 30000</p> <p>Hold Time(s)= 30.000</p> <p>Trig Force(lb)= 1600</p> <p>Ext U/S Delay</p> <p>Amplitude> STEP</p> <p>Amplitude(%)=</p> <p>Pretrigger> Off</p> <p>Afterburst> Off</p> <p>Energy Brake</p> <p>Post Weld Seek = Off</p> <p>Frequency Offset> Off</p> <p>Act Clr Output> Off</p> <p>Cycle Aborts> Off</p> <p>Timeout(s)= 30.000</p> <p>Control Limits > Off</p> <p>Suspect Limits > Off</p> <p>Reject Limits > Off</p> <p>Write In Fields</p> <p>Save/Recall Presets</p> <p>Pwr Match Curve</p> | <p>The Pop-up menu shown below allows you to set Energy Values. Energy parameter limits are displayed in the lower left field as Min and Max Value. You cannot successfully enter invalid values. Refer to Section 6.4.7 Keypad Operation for Keypad operation if necessary.</p>  |
|--|--|

6.7.1.3 Using Peak Power Weld Mode

You can use Peak Power Mode to select the maximum percentage or watts of the total available power that will be used to process your welds. When the power level you set is reached, ultrasonics will be terminated. From within Peak Power Mode, you can also select several other parameters, ranging from Hold Time (in seconds) to Suspect and Reject Limits. The following Table displays parameters for use in Peak Power Mode. The parameter input limits pop-up screen is accessed when the respective parameter Navigation button is touched. Refer to Section [6.4.5 Weld Setup Menu Screen](#) for all available parameter limits.

Figure 6.31 Peak Power Weld Mode Setup

| | | | | | |
|--|---|--------------|-----------|------------|--------|
| <p>WELD SETUP</p> <p>Weld Mode> Peak Power</p> <p>Peak Power(%)= 100.0</p> <p>Hold time(s)= 30.000</p> <p>Trig Force(lb)=</p> <p>Ext U/S Delay</p> <p>Amplitude> STEP</p> <p>Amplitude(%)=</p> <p>Pretrigger> Off</p> <p>Afterburst> Off</p> <p>Energy Brake</p> <p>Post Weld Seek = Off</p> <p>Frequency Offset> Off</p> <p>Act Clr Output> Off</p> <p>Cycle Aborts> Off</p> <p>Timeout(S)= 30.000</p> <p>Control Limits > Off</p> <p>Suspect Limits > Off</p> <p>Reject Limits > Off</p> <p>Write In Fields</p> <p>Save/Recall Presets</p> <p>Pwr Match Curve</p> | <p>The Pop-up menu shown below allows you to set Peak Power Values. The Peak Power parameter limits are displayed in the lower left field. You cannot successfully enter invalid values. Refer to Section 6.4.7 Keypad Operation for Keypad operation if necessary.</p> | | | | |
| | <table border="1" style="margin: auto;"> <tr> <td>Weld Results</td> <td>Main Menu</td> <td>Weld Setup</td> <td>Graphs</td> </tr> </table> | Weld Results | Main Menu | Weld Setup | Graphs |
| Weld Results | Main Menu | Weld Setup | Graphs | | |

6.7.1.4 Using Collapse Distance Weld Mode

You can use the Collapse Distance Mode to select the distance your part will be collapsed before ultrasonic energy is terminated. This distance parameter can be set when in Collapse Mode to establish Suspect and Reject Limits. Total Collapse Limits in Collapse Mode is that value achieved at the end of Hold. Within Collapse Mode, you can also select several other parameters, ranging from Hold Time (in seconds) to Suspect and Reject limits. The following Table displays parameters for use in Collapse Distance Mode. The parameter input limits pop-up screen is accessed when the respective parameter Navigation button is touched. Refer to Section [6.4.5 Weld Setup Menu Screen](#) for all available parameter limits.

Figure 6.32 Collapse Distance Weld Mode Setup

| | |
|--|--|
| <p>WELD SETUP</p> <p>Weld Mode> Collapse</p> <p>Collapse(in)= 1.0000</p> <p>Hold Time(s)= 30.000</p> <p>Trig Force(lb)=</p> <p>Ext U/S Delay</p> <p>Amplitude> STEP</p> <p>Amplitude(%)=</p> <p>Pretrigger> Off</p> <p>Afterburst> Off</p> <p>Energy Brake</p> <p>Post Weld Seek = Off</p> <p>Frequency Offset> Off</p> <p>Act Clr Output> Off</p> <p>Cycle Aborts> Off</p> <p>Timeout(s)= 30.000</p> <p>Control Limits > Off</p> <p>Suspect Limits > Off</p> <p>Reject Limits > Off</p> <p>Write In Fields</p> <p>Save/Recall Presets</p> <p>Pwr Match Curve</p> | <p>The Pop-up menu shown below appears to allow you to set Collapse Distance Values. The Collapse Distance parameter limits are displayed in the lower left field as Min and Max Value. You cannot successfully enter invalid values. Refer to Section 6.4.7 Keypad Operation for Keypad operation if necessary.</p> |
|--|--|

| | | |
|--|-----|----------|
| WELD SETUP | | Pg 1 / 2 |
| Collapse[in] | | |
| Current Value | # | ABC DEF |
| <input style="width: 100%;" type="text" value="0.0004"/> | 1 | 2 3 |
| New Value | GHI | JKL MNO |
| <input style="width: 100%;" type="text" value="-"/> | 4 | 5 6 |
| Min Value 0.0004 | PQR | STU VWX |
| Max Value 1.0000 | 7 | 8 9 |
| | + | YZ - |
| | INC | 0 DEC |
| | ESC | . ENT |

| | | | |
|--------------|-----------|------------|--------|
| Weld Results | Main Menu | Weld Setup | Graphs |
|--------------|-----------|------------|--------|

6.7.1.5 Using Absolute Distance Weld Mode

You can use the Absolute Distance Mode to select the distance the horn will travel before ultrasonic energy is terminated. Within Absolute Mode, you can also select several other parameters ranging from Hold Time (in seconds) to Suspect and Reject limits. The following Table displays parameters for use in Absolute Distance Mode. The parameter input limits pop-up screen is accessed when the respective parameter Navigation button is touched. Refer to Section [6.4.5 Weld Setup Menu Screen](#) for all available parameter limits.

Figure 6.33 Absolute Distance Weld Mode Setup

| | |
|--|---|
| <p>WELD SETUP</p> <p>Weld Mode> Absolute</p> <p>Absolute(in)= 1.0000</p> <p>Hold time(s)= 30.000</p> <p>Trig Force(lb)=</p> <p>Ext U/S Delay</p> <p>Amplitude> STEP</p> <p>Amplitude(%)=</p> <p>Pretrigger> Off</p> <p>Afterburst> Off</p> <p>Energy Brake</p> <p>Post Weld Seek = Off</p> <p>Frequency Offset> Off</p> <p>Act Clr Output> Off</p> <p>Cycle Aborts> Off</p> <p>Timeout(s)= 30.000</p> <p>Control Limits > Off</p> <p>Suspect Limits > Off</p> <p>Reject Limits > Off</p> <p>Write In Fields</p> <p>Save/Recall Presets</p> <p>Pwr Match Curve</p> | <p>The Pop-up menu shown below appears to allow you to set Absolute Distance Values. The Absolute Distance parameter limits are displayed in the lower left field as Min and Max Values. You cannot successfully enter invalid values. Refer to Section 6.4.7 Keypad Operation for Keypad operation if necessary.</p> |
|--|---|

6.7.1.6 Using Ground Detect Weld Mode

You can use Ground Detect Weld Mode to have ultrasonic energy turn off when the horn comes in contact with your electrically isolated fixture or anvil. The electrically isolated fixture should be so designed that the insulator allows no continuity to the actuator base. It is necessary to install Branson cable EDP No. 100-246-630 from the MPS/GDS receptacle on the rear of the actuator to your isolated fixture/anvil in order to utilize this feature.

From within Ground Detect Mode, you can also select several other parameters, ranging from Hold Time (in seconds) to Suspect and Reject Limits. The following Table displays parameters for use in Ground Detect Mode. The parameter input limits pop-up screen is accessed when the respective parameter Navigation button is touched. Refer to Section [6.4.5 Weld Setup Menu Screen](#) for all available parameter limits.

Figure 6.34 Ground Detect Weld Mode Setup

| | |
|--|---|
| <p>WELD SETUP</p> <p>Weld Mode> Gnd Detect</p> <p>Scrub Time(s)= 0.500</p> <p>Scrub Amplitude=10%</p> <p>Hold Time(s) 30.000</p> <p>Trig Force(lb)=</p> <p>Ext U/S Delay</p> <p>Amplitude> STEP</p> <p>Amplitude(%)=</p> <p>Pretrigger> Off</p> <p>Afterburst> Off</p> <p>Energy Brake</p> <p>Post Weld Seek = Off</p> <p>Frequency Offset> Off</p> <p>Act Clr Output> Off</p> <p>Cycle Aborts> Off</p> <p>Timeout(s)= 30.000</p> <p>Control Limits > Off</p> <p>Suspect Limits > Off</p> <p>Reject Limits > Off</p> <p>Write In Fields</p> <p>Save/Recall Presets</p> <p>Pwr Match Curve</p> | <p>The Pop-up menu shown below allows you to set Ground Detect Scrub Time Values. The Ground Detect parameter limits are displayed in the lower left field as Min and Max Value. You cannot successfully enter invalid values. Refer to Section 6.4.7 Keypad Operation for Keypad operation if necessary.</p> |
|--|---|

WELD SETUP
Pg 1 / 2

Scrub Time[s]

Current Value
0.001

New Value
-

Min Value 0.001

Max Value 0.500

OFF

| | | |
|-----|-----|-----|
| # | ABC | DEF |
| 1 | 2 | 3 |
| GHI | JKL | MNO |
| 4 | 5 | 6 |
| PQR | STU | VWX |
| 7 | 8 | 9 |
| + | YZ | - |
| INC | 0 | DEC |
| ESC | . | ENT |

Weld Results
Main Menu
Weld Setup
Graphs

6.7.2 Setting Other Weld Parameters

From within each individual welding mode, you can also select several other parameters. This section describes each of these parameters and the procedures for setting them.

6.7.2.1 Hold Time (s)

You can select the duration (in seconds) of the Hold step (the step during which there is no ultrasonic energy transmitted to your part, but pressure is maintained) in welding your parts, or select not to have a Hold Time.

The Hold Time Pop-up limit screen is shown. Minimum and Maximum allowable values are shown in the lower left corner field. You are not able to enter an invalid parameter limit.

| WELD SETUP | | Pg 1 of 3 | | |
|---------------------|-----|-----------|-----|------------|
| Hold Time[s] | | | | |
| Current Value | # | ABC | DEF | |
| 0.894 | 1 | 2 | 3 | |
| New Value | GHI | JKL | MNO | |
| - | 4 | 5 | 6 | |
| Min Value 0.010 | PQR | STU | VWX | |
| Max Value 30.000 | 7 | 8 | 9 | |
| OFF | + | YZ | - | |
| | INC | 0 | DEC | |
| | ESC | . | ENT | |
| Weld Results | | Main Menu | | Weld Setup |
| | | | | Graphs |

6.7.2.2 Trig Force (lb)

You can select the number of pounds (Newtons) of trigger force that will trigger ultrasonics. When the force on your part is equal to the value you have set, ultrasonic energy is applied. Minimum and Maximum allowable values are shown in the lower left corner field. You are not able to enter an invalid parameter limit.

| WELD SETUP | | Pg 1 of 3 | | |
|-----------------------|-----|-----------|-----|------------|
| Trig Force[lb] | | | | |
| Current Value | # | ABC | DEF | |
| 10 | 1 | 2 | 3 | |
| New Value | GHI | JKL | MNO | |
| - | 4 | 5 | 6 | |
| Min Value 5 | PQR | STU | VWX | |
| Max Value 282 | 7 | 8 | 9 | |
| OFF | + | YZ | - | |
| | INC | 0 | DEC | |
| | ESC | . | ENT | |
| Weld Results | | Main Menu | | Weld Setup |
| | | | | Graphs |

6.7.2.3 External U/S Delay

If External U/S Delay is enabled (turned on), weld state machine shall wait for external trigger delay input to become active in less than 30 seconds. When the time expires and input is still inactive, alarm will be recorded and cycle aborted.

6.7.2.4 Amplitude (%/μm)

You can set the amplitude of the ultrasonic energy that will be delivered in any welding mode. The Power Supply's default is to use 100% of the available amplitude. By changing the amplitude to some lesser percentage of the total available, or by setting the amplitude to begin at one level and finish at another, you can "fine tune" your overall welding procedure without making changes to your tooling (converter, booster, horn, or fixture).

You can select the amplitude to use when Amplitude is fixed. If Amplitude is Stepped, this parameter is inactive and the display shows *** for Amplitude (%). If you set Amplitude Control to External in System Configuration, this parameter is inactive and the display shows Ext for Amplitude (%/μm).

6.7.2.5 Amplitude> STEP

You can select whether you want to apply a fixed or stepped amplitude to the part during welding. If Step was selected ON from the Weld Setup page the following screens will be shown. Pressing Amplitude displays a screen with two choices, STEP or FIXED. If FIXED was selected ON from Weld Setup, the screen with 2 choices, STEP or FIXED is displayed. If you choose to use a stepped amplitude, you must also choose the first and second amplitudes (each as a percentage of the maximum) to use before and after the step point, as well as the criteria to use the step. The first screen shows the navigation options for stepped amplitude.

| Weld Setup > Amplitude | Amplitude Step Page |
|------------------------|---------------------|
| | |

The following screens display the keypads for the respective navigation buttons.

| Set Amplitude Step A Screen | Set Amplitude Step B Screen | | | | | | | | | | | | | | | | | | | | | | | | | | | | | | | | | | | | | | | | | | | | | | | | | | | | | | | | | | | | | | | | | | | | | | | | |
|--|-----------------------------|-----|-----|-----|----|---|---|---|-----------|-----|-----|-----|---|---|---|---|--------------|-----|-----|-----|---------------|---|---|---|--|---|----|---|--|-----|---|-----|--|-----|---|-----|--|---------------|---|-----|-----|----|---|---|---|-----------|-----|-----|-----|---|---|---|---|--------------|-----|-----|-----|---------------|---|---|---|--|---|----|---|--|-----|---|-----|--|-----|---|-----|
| <div style="background-color: #0056b3; color: white; padding: 5px; font-weight: bold;">AMP STEP</div> <div style="background-color: #ffff00; padding: 10px; border: 1px solid #0056b3;"> <div style="background-color: #0056b3; color: white; padding: 5px; font-weight: bold; text-align: center;">Amplitude A[%]</div> <table style="width: 100%; border-collapse: collapse;"> <tr> <td style="width: 30%;">Current Value</td> <td style="width: 10%; text-align: center;">#</td> <td style="width: 10%;">ABC</td> <td style="width: 10%;">DEF</td> </tr> <tr> <td style="border: 1px solid #ccc; padding: 2px;">89</td> <td style="text-align: center;">1</td> <td style="text-align: center;">2</td> <td style="text-align: center;">3</td> </tr> <tr> <td>New Value</td> <td style="text-align: center;">GHI</td> <td style="text-align: center;">JKL</td> <td style="text-align: center;">MNO</td> </tr> <tr> <td style="border: 1px solid #ccc; padding: 2px;">-</td> <td style="text-align: center;">4</td> <td style="text-align: center;">5</td> <td style="text-align: center;">6</td> </tr> <tr> <td>Min Value 10</td> <td style="text-align: center;">PQR</td> <td style="text-align: center;">STU</td> <td style="text-align: center;">VWX</td> </tr> <tr> <td>Max Value 100</td> <td style="text-align: center;">7</td> <td style="text-align: center;">8</td> <td style="text-align: center;">9</td> </tr> <tr> <td></td> <td style="text-align: center;">+</td> <td style="text-align: center;">YZ</td> <td style="text-align: center;">-</td> </tr> <tr> <td></td> <td style="text-align: center;">INC</td> <td style="text-align: center;">0</td> <td style="text-align: center;">DEC</td> </tr> <tr> <td></td> <td style="text-align: center;">ESC</td> <td style="text-align: center;">.</td> <td style="text-align: center;">ENT</td> </tr> </table> </div> <div style="background-color: #0056b3; color: white; padding: 5px; font-weight: bold; display: flex; justify-content: space-between;"> Weld Results Main Menu Weld Setup Graphs </div> | Current Value | # | ABC | DEF | 89 | 1 | 2 | 3 | New Value | GHI | JKL | MNO | - | 4 | 5 | 6 | Min Value 10 | PQR | STU | VWX | Max Value 100 | 7 | 8 | 9 | | + | YZ | - | | INC | 0 | DEC | | ESC | . | ENT | <div style="background-color: #0056b3; color: white; padding: 5px; font-weight: bold;">AMP STEP</div> <div style="background-color: #ffff00; padding: 10px; border: 1px solid #0056b3;"> <div style="background-color: #0056b3; color: white; padding: 5px; font-weight: bold; text-align: center;">Amplitude B[%]</div> <table style="width: 100%; border-collapse: collapse;"> <tr> <td style="width: 30%;">Current Value</td> <td style="width: 10%; text-align: center;">#</td> <td style="width: 10%;">ABC</td> <td style="width: 10%;">DEF</td> </tr> <tr> <td style="border: 1px solid #ccc; padding: 2px;">89</td> <td style="text-align: center;">1</td> <td style="text-align: center;">2</td> <td style="text-align: center;">3</td> </tr> <tr> <td>New Value</td> <td style="text-align: center;">GHI</td> <td style="text-align: center;">JKL</td> <td style="text-align: center;">MNO</td> </tr> <tr> <td style="border: 1px solid #ccc; padding: 2px;">-</td> <td style="text-align: center;">4</td> <td style="text-align: center;">5</td> <td style="text-align: center;">6</td> </tr> <tr> <td>Min Value 10</td> <td style="text-align: center;">PQR</td> <td style="text-align: center;">STU</td> <td style="text-align: center;">VWX</td> </tr> <tr> <td>Max Value 100</td> <td style="text-align: center;">7</td> <td style="text-align: center;">8</td> <td style="text-align: center;">9</td> </tr> <tr> <td></td> <td style="text-align: center;">+</td> <td style="text-align: center;">YZ</td> <td style="text-align: center;">-</td> </tr> <tr> <td></td> <td style="text-align: center;">INC</td> <td style="text-align: center;">0</td> <td style="text-align: center;">DEC</td> </tr> <tr> <td></td> <td style="text-align: center;">ESC</td> <td style="text-align: center;">.</td> <td style="text-align: center;">ENT</td> </tr> </table> </div> <div style="background-color: #0056b3; color: white; padding: 5px; font-weight: bold; display: flex; justify-content: space-between;"> Weld Results Main Menu Weld Setup Graphs </div> | Current Value | # | ABC | DEF | 89 | 1 | 2 | 3 | New Value | GHI | JKL | MNO | - | 4 | 5 | 6 | Min Value 10 | PQR | STU | VWX | Max Value 100 | 7 | 8 | 9 | | + | YZ | - | | INC | 0 | DEC | | ESC | . | ENT |
| Current Value | # | ABC | DEF | | | | | | | | | | | | | | | | | | | | | | | | | | | | | | | | | | | | | | | | | | | | | | | | | | | | | | | | | | | | | | | | | | | | | | |
| 89 | 1 | 2 | 3 | | | | | | | | | | | | | | | | | | | | | | | | | | | | | | | | | | | | | | | | | | | | | | | | | | | | | | | | | | | | | | | | | | | | | | |
| New Value | GHI | JKL | MNO | | | | | | | | | | | | | | | | | | | | | | | | | | | | | | | | | | | | | | | | | | | | | | | | | | | | | | | | | | | | | | | | | | | | | | |
| - | 4 | 5 | 6 | | | | | | | | | | | | | | | | | | | | | | | | | | | | | | | | | | | | | | | | | | | | | | | | | | | | | | | | | | | | | | | | | | | | | | |
| Min Value 10 | PQR | STU | VWX | | | | | | | | | | | | | | | | | | | | | | | | | | | | | | | | | | | | | | | | | | | | | | | | | | | | | | | | | | | | | | | | | | | | | | |
| Max Value 100 | 7 | 8 | 9 | | | | | | | | | | | | | | | | | | | | | | | | | | | | | | | | | | | | | | | | | | | | | | | | | | | | | | | | | | | | | | | | | | | | | | |
| | + | YZ | - | | | | | | | | | | | | | | | | | | | | | | | | | | | | | | | | | | | | | | | | | | | | | | | | | | | | | | | | | | | | | | | | | | | | | | |
| | INC | 0 | DEC | | | | | | | | | | | | | | | | | | | | | | | | | | | | | | | | | | | | | | | | | | | | | | | | | | | | | | | | | | | | | | | | | | | | | | |
| | ESC | . | ENT | | | | | | | | | | | | | | | | | | | | | | | | | | | | | | | | | | | | | | | | | | | | | | | | | | | | | | | | | | | | | | | | | | | | | | |
| Current Value | # | ABC | DEF | | | | | | | | | | | | | | | | | | | | | | | | | | | | | | | | | | | | | | | | | | | | | | | | | | | | | | | | | | | | | | | | | | | | | | |
| 89 | 1 | 2 | 3 | | | | | | | | | | | | | | | | | | | | | | | | | | | | | | | | | | | | | | | | | | | | | | | | | | | | | | | | | | | | | | | | | | | | | | |
| New Value | GHI | JKL | MNO | | | | | | | | | | | | | | | | | | | | | | | | | | | | | | | | | | | | | | | | | | | | | | | | | | | | | | | | | | | | | | | | | | | | | | |
| - | 4 | 5 | 6 | | | | | | | | | | | | | | | | | | | | | | | | | | | | | | | | | | | | | | | | | | | | | | | | | | | | | | | | | | | | | | | | | | | | | | |
| Min Value 10 | PQR | STU | VWX | | | | | | | | | | | | | | | | | | | | | | | | | | | | | | | | | | | | | | | | | | | | | | | | | | | | | | | | | | | | | | | | | | | | | | |
| Max Value 100 | 7 | 8 | 9 | | | | | | | | | | | | | | | | | | | | | | | | | | | | | | | | | | | | | | | | | | | | | | | | | | | | | | | | | | | | | | | | | | | | | | |
| | + | YZ | - | | | | | | | | | | | | | | | | | | | | | | | | | | | | | | | | | | | | | | | | | | | | | | | | | | | | | | | | | | | | | | | | | | | | | | |
| | INC | 0 | DEC | | | | | | | | | | | | | | | | | | | | | | | | | | | | | | | | | | | | | | | | | | | | | | | | | | | | | | | | | | | | | | | | | | | | | | |
| | ESC | . | ENT | | | | | | | | | | | | | | | | | | | | | | | | | | | | | | | | | | | | | | | | | | | | | | | | | | | | | | | | | | | | | | | | | | | | | | |

Use the respective keypads to select values from 10%/μm to 100% and enter % Amplitude at Step A, and then Step B.

| Amplitude Step @ Time in Seconds | Amplitude Step @ Energy in Joules | | | | | | | | | | | | | | | | | | | | | | | | | | | | | | | | | | | | | | | | | | | | | | | | | | | | | | | | | | | | | | | | | | | | | | | | |
|--|-----------------------------------|-----|-----|-----|-------|---|---|---|-----------|-----|-----|-----|---|---|---|---|-----------------|-----|-----|-----|------------------|---|---|---|--|---|----|---|--|-----|---|-----|--|-----|---|-----|---|---------------|---|-----|-----|-----|---|---|---|-----------|-----|-----|-----|---|---|---|---|---------------|-----|-----|-----|-------------------|---|---|---|--|---|----|---|--|-----|---|-----|--|-----|---|-----|
| <div style="background-color: #0056b3; color: white; padding: 5px; font-weight: bold;">AMP STEP</div> <div style="background-color: #ffff00; padding: 10px; border: 1px solid #0056b3;"> <div style="background-color: #0056b3; color: white; padding: 5px; font-weight: bold; text-align: center;">Step @ T[s]</div> <table style="width: 100%; border-collapse: collapse;"> <tr> <td style="width: 30%;">Current Value</td> <td style="width: 10%; text-align: center;">#</td> <td style="width: 10%;">ABC</td> <td style="width: 10%;">DEF</td> </tr> <tr> <td style="border: 1px solid #ccc; padding: 2px;">0.500</td> <td style="text-align: center;">1</td> <td style="text-align: center;">2</td> <td style="text-align: center;">3</td> </tr> <tr> <td>New Value</td> <td style="text-align: center;">GHI</td> <td style="text-align: center;">JKL</td> <td style="text-align: center;">MNO</td> </tr> <tr> <td style="border: 1px solid #ccc; padding: 2px;">-</td> <td style="text-align: center;">4</td> <td style="text-align: center;">5</td> <td style="text-align: center;">6</td> </tr> <tr> <td>Min Value 0.010</td> <td style="text-align: center;">PQR</td> <td style="text-align: center;">STU</td> <td style="text-align: center;">VWX</td> </tr> <tr> <td>Max Value 30.000</td> <td style="text-align: center;">7</td> <td style="text-align: center;">8</td> <td style="text-align: center;">9</td> </tr> <tr> <td></td> <td style="text-align: center;">+</td> <td style="text-align: center;">YZ</td> <td style="text-align: center;">-</td> </tr> <tr> <td></td> <td style="text-align: center;">INC</td> <td style="text-align: center;">0</td> <td style="text-align: center;">DEC</td> </tr> <tr> <td></td> <td style="text-align: center;">ESC</td> <td style="text-align: center;">.</td> <td style="text-align: center;">ENT</td> </tr> </table> </div> <div style="background-color: #0056b3; color: white; padding: 5px; font-weight: bold; display: flex; justify-content: space-between;"> Weld Results Main Menu Weld Setup Graphs </div> | Current Value | # | ABC | DEF | 0.500 | 1 | 2 | 3 | New Value | GHI | JKL | MNO | - | 4 | 5 | 6 | Min Value 0.010 | PQR | STU | VWX | Max Value 30.000 | 7 | 8 | 9 | | + | YZ | - | | INC | 0 | DEC | | ESC | . | ENT | <div style="background-color: #0056b3; color: white; padding: 5px; font-weight: bold;">AMP STEP</div> <div style="background-color: #ffff00; padding: 10px; border: 1px solid #0056b3;"> <div style="background-color: #0056b3; color: white; padding: 5px; font-weight: bold; text-align: center;">Step @ E[J]</div> <table style="width: 100%; border-collapse: collapse;"> <tr> <td style="width: 30%;">Current Value</td> <td style="width: 10%; text-align: center;">#</td> <td style="width: 10%;">ABC</td> <td style="width: 10%;">DEF</td> </tr> <tr> <td style="border: 1px solid #ccc; padding: 2px;">1.0</td> <td style="text-align: center;">1</td> <td style="text-align: center;">2</td> <td style="text-align: center;">3</td> </tr> <tr> <td>New Value</td> <td style="text-align: center;">GHI</td> <td style="text-align: center;">JKL</td> <td style="text-align: center;">MNO</td> </tr> <tr> <td style="border: 1px solid #ccc; padding: 2px;">-</td> <td style="text-align: center;">4</td> <td style="text-align: center;">5</td> <td style="text-align: center;">6</td> </tr> <tr> <td>Min Value 1.0</td> <td style="text-align: center;">PQR</td> <td style="text-align: center;">STU</td> <td style="text-align: center;">VWX</td> </tr> <tr> <td>Max Value 24000.0</td> <td style="text-align: center;">7</td> <td style="text-align: center;">8</td> <td style="text-align: center;">9</td> </tr> <tr> <td></td> <td style="text-align: center;">+</td> <td style="text-align: center;">YZ</td> <td style="text-align: center;">-</td> </tr> <tr> <td></td> <td style="text-align: center;">INC</td> <td style="text-align: center;">0</td> <td style="text-align: center;">DEC</td> </tr> <tr> <td></td> <td style="text-align: center;">ESC</td> <td style="text-align: center;">.</td> <td style="text-align: center;">ENT</td> </tr> </table> </div> <div style="background-color: #0056b3; color: white; padding: 5px; font-weight: bold; display: flex; justify-content: space-between;"> Weld Results Main Menu Weld Setup Graphs </div> | Current Value | # | ABC | DEF | 1.0 | 1 | 2 | 3 | New Value | GHI | JKL | MNO | - | 4 | 5 | 6 | Min Value 1.0 | PQR | STU | VWX | Max Value 24000.0 | 7 | 8 | 9 | | + | YZ | - | | INC | 0 | DEC | | ESC | . | ENT |
| Current Value | # | ABC | DEF | | | | | | | | | | | | | | | | | | | | | | | | | | | | | | | | | | | | | | | | | | | | | | | | | | | | | | | | | | | | | | | | | | | | | | |
| 0.500 | 1 | 2 | 3 | | | | | | | | | | | | | | | | | | | | | | | | | | | | | | | | | | | | | | | | | | | | | | | | | | | | | | | | | | | | | | | | | | | | | | |
| New Value | GHI | JKL | MNO | | | | | | | | | | | | | | | | | | | | | | | | | | | | | | | | | | | | | | | | | | | | | | | | | | | | | | | | | | | | | | | | | | | | | | |
| - | 4 | 5 | 6 | | | | | | | | | | | | | | | | | | | | | | | | | | | | | | | | | | | | | | | | | | | | | | | | | | | | | | | | | | | | | | | | | | | | | | |
| Min Value 0.010 | PQR | STU | VWX | | | | | | | | | | | | | | | | | | | | | | | | | | | | | | | | | | | | | | | | | | | | | | | | | | | | | | | | | | | | | | | | | | | | | | |
| Max Value 30.000 | 7 | 8 | 9 | | | | | | | | | | | | | | | | | | | | | | | | | | | | | | | | | | | | | | | | | | | | | | | | | | | | | | | | | | | | | | | | | | | | | | |
| | + | YZ | - | | | | | | | | | | | | | | | | | | | | | | | | | | | | | | | | | | | | | | | | | | | | | | | | | | | | | | | | | | | | | | | | | | | | | | |
| | INC | 0 | DEC | | | | | | | | | | | | | | | | | | | | | | | | | | | | | | | | | | | | | | | | | | | | | | | | | | | | | | | | | | | | | | | | | | | | | | |
| | ESC | . | ENT | | | | | | | | | | | | | | | | | | | | | | | | | | | | | | | | | | | | | | | | | | | | | | | | | | | | | | | | | | | | | | | | | | | | | | |
| Current Value | # | ABC | DEF | | | | | | | | | | | | | | | | | | | | | | | | | | | | | | | | | | | | | | | | | | | | | | | | | | | | | | | | | | | | | | | | | | | | | | |
| 1.0 | 1 | 2 | 3 | | | | | | | | | | | | | | | | | | | | | | | | | | | | | | | | | | | | | | | | | | | | | | | | | | | | | | | | | | | | | | | | | | | | | | |
| New Value | GHI | JKL | MNO | | | | | | | | | | | | | | | | | | | | | | | | | | | | | | | | | | | | | | | | | | | | | | | | | | | | | | | | | | | | | | | | | | | | | | |
| - | 4 | 5 | 6 | | | | | | | | | | | | | | | | | | | | | | | | | | | | | | | | | | | | | | | | | | | | | | | | | | | | | | | | | | | | | | | | | | | | | | |
| Min Value 1.0 | PQR | STU | VWX | | | | | | | | | | | | | | | | | | | | | | | | | | | | | | | | | | | | | | | | | | | | | | | | | | | | | | | | | | | | | | | | | | | | | | |
| Max Value 24000.0 | 7 | 8 | 9 | | | | | | | | | | | | | | | | | | | | | | | | | | | | | | | | | | | | | | | | | | | | | | | | | | | | | | | | | | | | | | | | | | | | | | |
| | + | YZ | - | | | | | | | | | | | | | | | | | | | | | | | | | | | | | | | | | | | | | | | | | | | | | | | | | | | | | | | | | | | | | | | | | | | | | | |
| | INC | 0 | DEC | | | | | | | | | | | | | | | | | | | | | | | | | | | | | | | | | | | | | | | | | | | | | | | | | | | | | | | | | | | | | | | | | | | | | | |
| | ESC | . | ENT | | | | | | | | | | | | | | | | | | | | | | | | | | | | | | | | | | | | | | | | | | | | | | | | | | | | | | | | | | | | | | | | | | | | | | |

Select values within the limits shown in the lower left field and enter Step @ Time in seconds, and Step @ Energy in Joules respectively.

| Amplitude Step @ %/W of Peak Power | Amplitude Step @ Collapse Distance | | | | | | | | | | | | | | | | | | | | | | | | | | | | | | | | | | | | | | | | | | | | | | | | | | | | | | | | | | | | | | | | | | | | | | | | | | | | | | | | | | | | | | | | | | | | | | | | |
|--|---|-----|----|-----|-----|-----|-----|---|-----------|----|-----|---|-----|---|-----|---|-----------|-----|-----|---|-----|---|-----|---|-----------|-------|---|----|---|--|--|--|--|--|-----|---|-----|--|--|--|--|--|-----|---|-----|--|--|--|---|---------------|--------|---|---|-----|---|-----|---|-----------|---|-----|---|-----|---|-----|---|-----------|--------|-----|---|-----|---|-----|---|-----------|--------|---|----|---|--|--|--|--|--|-----|---|-----|--|--|--|--|--|-----|---|-----|--|--|--|
| <div style="background-color: #0056b3; color: white; padding: 5px; font-weight: bold;">AMP STEP</div> <div style="background-color: #ffff00; padding: 10px;"> <div style="background-color: #0056b3; color: white; padding: 5px; font-weight: bold; text-align: center;">Step @ Pwr[%]</div> <table style="width: 100%; border-collapse: collapse;"> <tr> <td style="width: 25%;">Current Value</td> <td style="width: 10%; border: 1px solid black;">1.0</td> <td style="width: 10%; border: 1px solid black;">#</td> <td style="width: 10%; border: 1px solid black;">1</td> <td style="width: 10%; border: 1px solid black;">ABC</td> <td style="width: 10%; border: 1px solid black;">2</td> <td style="width: 10%; border: 1px solid black;">DEF</td> <td style="width: 10%; border: 1px solid black;">3</td> </tr> <tr> <td>New Value</td> <td style="border: 1px solid black;">9_</td> <td style="border: 1px solid black;">GHI</td> <td style="border: 1px solid black;">4</td> <td style="border: 1px solid black;">JKL</td> <td style="border: 1px solid black;">5</td> <td style="border: 1px solid black;">MNO</td> <td style="border: 1px solid black;">6</td> </tr> <tr> <td>Min Value</td> <td>1.0</td> <td style="border: 1px solid black;">PQR</td> <td style="border: 1px solid black;">7</td> <td style="border: 1px solid black;">STU</td> <td style="border: 1px solid black;">8</td> <td style="border: 1px solid black;">VWX</td> <td style="border: 1px solid black;">9</td> </tr> <tr> <td>Max Value</td> <td>100.0</td> <td style="border: 1px solid black;">+</td> <td style="border: 1px solid black;">YZ</td> <td style="border: 1px solid black;">-</td> <td colspan="2"></td> <td></td> </tr> <tr> <td></td> <td></td> <td style="border: 1px solid black;">INC</td> <td style="border: 1px solid black;">0</td> <td style="border: 1px solid black;">DEC</td> <td colspan="2"></td> <td></td> </tr> <tr> <td></td> <td></td> <td style="border: 1px solid black;">ESC</td> <td style="border: 1px solid black;">.</td> <td style="border: 1px solid black;">ENT</td> <td colspan="2"></td> <td></td> </tr> </table> </div> | Current Value | 1.0 | # | 1 | ABC | 2 | DEF | 3 | New Value | 9_ | GHI | 4 | JKL | 5 | MNO | 6 | Min Value | 1.0 | PQR | 7 | STU | 8 | VWX | 9 | Max Value | 100.0 | + | YZ | - | | | | | | INC | 0 | DEC | | | | | | ESC | . | ENT | | | | <div style="background-color: #0056b3; color: white; padding: 5px; font-weight: bold;">AMP STEP</div> <div style="background-color: #ffff00; padding: 10px;"> <div style="background-color: #0056b3; color: white; padding: 5px; font-weight: bold; text-align: center;">Step @ Col[in]</div> <table style="width: 100%; border-collapse: collapse;"> <tr> <td style="width: 25%;">Current Value</td> <td style="width: 10%; border: 1px solid black;">0.0004</td> <td style="width: 10%; border: 1px solid black;">#</td> <td style="width: 10%; border: 1px solid black;">1</td> <td style="width: 10%; border: 1px solid black;">ABC</td> <td style="width: 10%; border: 1px solid black;">2</td> <td style="width: 10%; border: 1px solid black;">DEF</td> <td style="width: 10%; border: 1px solid black;">3</td> </tr> <tr> <td>New Value</td> <td style="border: 1px solid black;">-</td> <td style="border: 1px solid black;">GHI</td> <td style="border: 1px solid black;">4</td> <td style="border: 1px solid black;">JKL</td> <td style="border: 1px solid black;">5</td> <td style="border: 1px solid black;">MNO</td> <td style="border: 1px solid black;">6</td> </tr> <tr> <td>Min Value</td> <td>0.0004</td> <td style="border: 1px solid black;">PQR</td> <td style="border: 1px solid black;">7</td> <td style="border: 1px solid black;">STU</td> <td style="border: 1px solid black;">8</td> <td style="border: 1px solid black;">VWX</td> <td style="border: 1px solid black;">9</td> </tr> <tr> <td>Max Value</td> <td>1.0000</td> <td style="border: 1px solid black;">+</td> <td style="border: 1px solid black;">YZ</td> <td style="border: 1px solid black;">-</td> <td colspan="2"></td> <td></td> </tr> <tr> <td></td> <td></td> <td style="border: 1px solid black;">INC</td> <td style="border: 1px solid black;">0</td> <td style="border: 1px solid black;">DEC</td> <td colspan="2"></td> <td></td> </tr> <tr> <td></td> <td></td> <td style="border: 1px solid black;">ESC</td> <td style="border: 1px solid black;">.</td> <td style="border: 1px solid black;">ENT</td> <td colspan="2"></td> <td></td> </tr> </table> </div> | Current Value | 0.0004 | # | 1 | ABC | 2 | DEF | 3 | New Value | - | GHI | 4 | JKL | 5 | MNO | 6 | Min Value | 0.0004 | PQR | 7 | STU | 8 | VWX | 9 | Max Value | 1.0000 | + | YZ | - | | | | | | INC | 0 | DEC | | | | | | ESC | . | ENT | | | |
| Current Value | 1.0 | # | 1 | ABC | 2 | DEF | 3 | | | | | | | | | | | | | | | | | | | | | | | | | | | | | | | | | | | | | | | | | | | | | | | | | | | | | | | | | | | | | | | | | | | | | | | | | | | | | | | | | | | | | | | | | | |
| New Value | 9_ | GHI | 4 | JKL | 5 | MNO | 6 | | | | | | | | | | | | | | | | | | | | | | | | | | | | | | | | | | | | | | | | | | | | | | | | | | | | | | | | | | | | | | | | | | | | | | | | | | | | | | | | | | | | | | | | | | |
| Min Value | 1.0 | PQR | 7 | STU | 8 | VWX | 9 | | | | | | | | | | | | | | | | | | | | | | | | | | | | | | | | | | | | | | | | | | | | | | | | | | | | | | | | | | | | | | | | | | | | | | | | | | | | | | | | | | | | | | | | | | |
| Max Value | 100.0 | + | YZ | - | | | | | | | | | | | | | | | | | | | | | | | | | | | | | | | | | | | | | | | | | | | | | | | | | | | | | | | | | | | | | | | | | | | | | | | | | | | | | | | | | | | | | | | | | | | | | |
| | | INC | 0 | DEC | | | | | | | | | | | | | | | | | | | | | | | | | | | | | | | | | | | | | | | | | | | | | | | | | | | | | | | | | | | | | | | | | | | | | | | | | | | | | | | | | | | | | | | | | | | | | |
| | | ESC | . | ENT | | | | | | | | | | | | | | | | | | | | | | | | | | | | | | | | | | | | | | | | | | | | | | | | | | | | | | | | | | | | | | | | | | | | | | | | | | | | | | | | | | | | | | | | | | | | | |
| Current Value | 0.0004 | # | 1 | ABC | 2 | DEF | 3 | | | | | | | | | | | | | | | | | | | | | | | | | | | | | | | | | | | | | | | | | | | | | | | | | | | | | | | | | | | | | | | | | | | | | | | | | | | | | | | | | | | | | | | | | | |
| New Value | - | GHI | 4 | JKL | 5 | MNO | 6 | | | | | | | | | | | | | | | | | | | | | | | | | | | | | | | | | | | | | | | | | | | | | | | | | | | | | | | | | | | | | | | | | | | | | | | | | | | | | | | | | | | | | | | | | | |
| Min Value | 0.0004 | PQR | 7 | STU | 8 | VWX | 9 | | | | | | | | | | | | | | | | | | | | | | | | | | | | | | | | | | | | | | | | | | | | | | | | | | | | | | | | | | | | | | | | | | | | | | | | | | | | | | | | | | | | | | | | | | |
| Max Value | 1.0000 | + | YZ | - | | | | | | | | | | | | | | | | | | | | | | | | | | | | | | | | | | | | | | | | | | | | | | | | | | | | | | | | | | | | | | | | | | | | | | | | | | | | | | | | | | | | | | | | | | | | | |
| | | INC | 0 | DEC | | | | | | | | | | | | | | | | | | | | | | | | | | | | | | | | | | | | | | | | | | | | | | | | | | | | | | | | | | | | | | | | | | | | | | | | | | | | | | | | | | | | | | | | | | | | | |
| | | ESC | . | ENT | | | | | | | | | | | | | | | | | | | | | | | | | | | | | | | | | | | | | | | | | | | | | | | | | | | | | | | | | | | | | | | | | | | | | | | | | | | | | | | | | | | | | | | | | | | | | |
| <div style="display: flex; justify-content: space-around; font-size: small;"> Weld Results Main Menu Weld Setup Graphs </div> | <div style="display: flex; justify-content: space-around; font-size: small;"> Weld Results Main Menu Weld Setup Graphs </div> | | | | | | | | | | | | | | | | | | | | | | | | | | | | | | | | | | | | | | | | | | | | | | | | | | | | | | | | | | | | | | | | | | | | | | | | | | | | | | | | | | | | | | | | | | | | | | | | |

Select values within the limits shown in the lower left field and enter Step @ %/W of Peak Power, and Step @ Collapse in inches respectively. This is the distance the part collapses after the trigger.

Amplitude Step @ Ext Sig is toggled On/Off depending on whether an external signal will be used to trigger the amplitude step.

6.7.2.6 Pretrigger

You can select whether the ultrasonic energy will be started before the horn makes contact with the part. If you select ON, you can set the distance at which the pretrigger ultrasonics will be started, and the amplitude that will be used. Auto (pretrigger) is the default. When Auto Pretrigger is used, ultrasonic energy will start when the horn leaves the home position 1/8 in. (3.175 mm) travel. Pressing either the Auto or Dist button will give access to a keypad to enter Pretrg Amp(%) values. Pressing the Time will give access to a keypad to enter both Pretrg Amp(%/μm) and Pretrg@T(s) values.

PRETRIGGER

| | |
|-------------------------------|-------------------------------|
| <input type="checkbox"/> Off | <input type="checkbox"/> Auto |
| <input type="checkbox"/> Dist | <input type="checkbox"/> Time |

Exit
Save

Weld Results
Main Menu
Weld Setup
Graphs

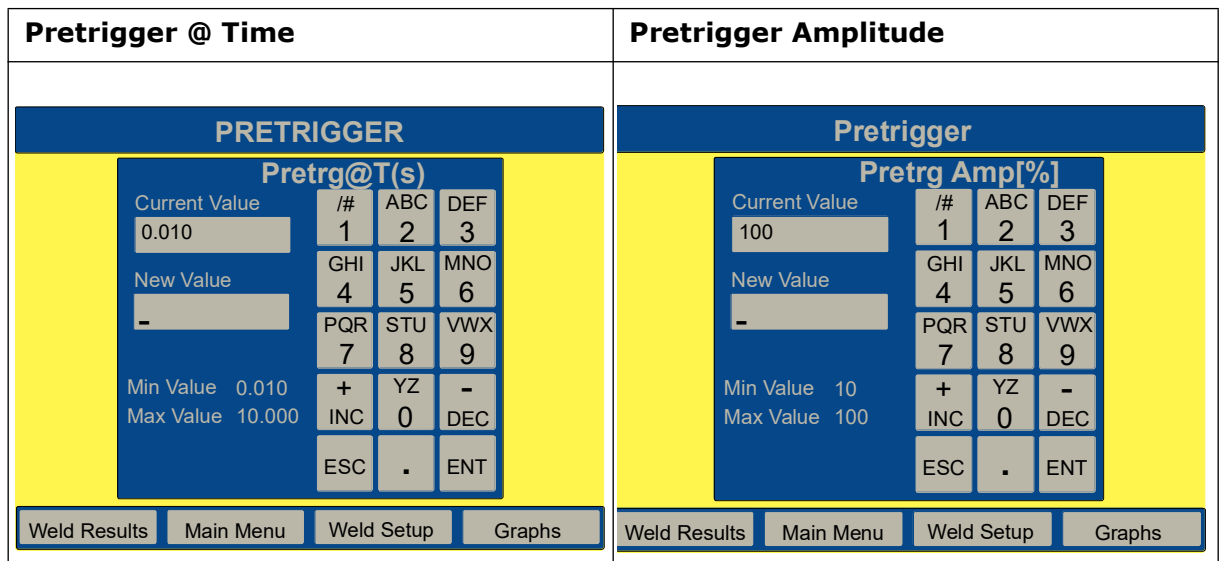

Select values within the limits shown in the lower left field and enter Distance and Amplitude.

6.7.2.7 Power Match Curve

You can enter \pm R Band limit values as a % of desired or expected Power to be compared with an actual Power curve of an acceptable weld. This provides a means of comparing welds in progress to previously determined successful weld parameters. Pressing the Enter Limits button will take you to the respective \pm R Band buttons, which when pressed will open a keypad to enter values. Limits are then tailored to maintain weld quality. You can add each new weld to get a composite average by pressing the Add to Average button. Limit bands are only displayed when limits are entered. The current weld will display as blue; the average displays red; and the limit bands will display as black.

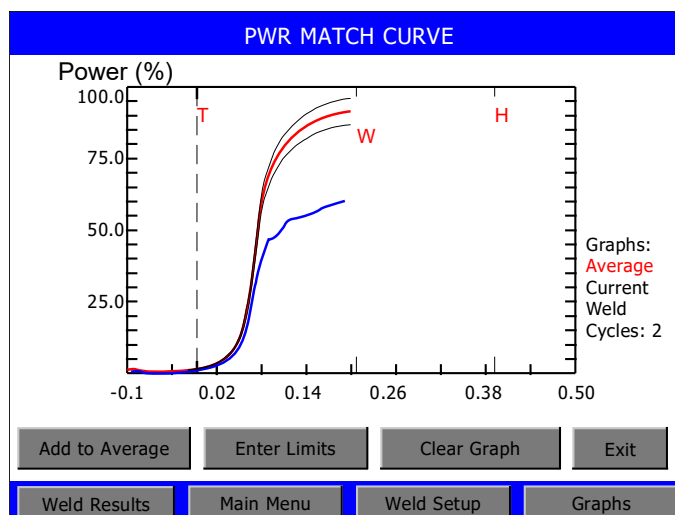

6.7.2.8 Energy Brake

Allows the user to set the power supply time to reduce the amplitude before the sonics are shut off. Any overloads that occur will be ignored in this state. They will be handled in the hold state. The time value limits are set using the pop-up keypad, limits are 0.010 to 1.000 seconds.

6.7.2.9 Digital UPS

Use this screen to setup the DUPS and view available presets. This screen will only appear if the power supply has a DUPS module (Digital Universal Power Supply). The DUPS navigation screen is shown below.

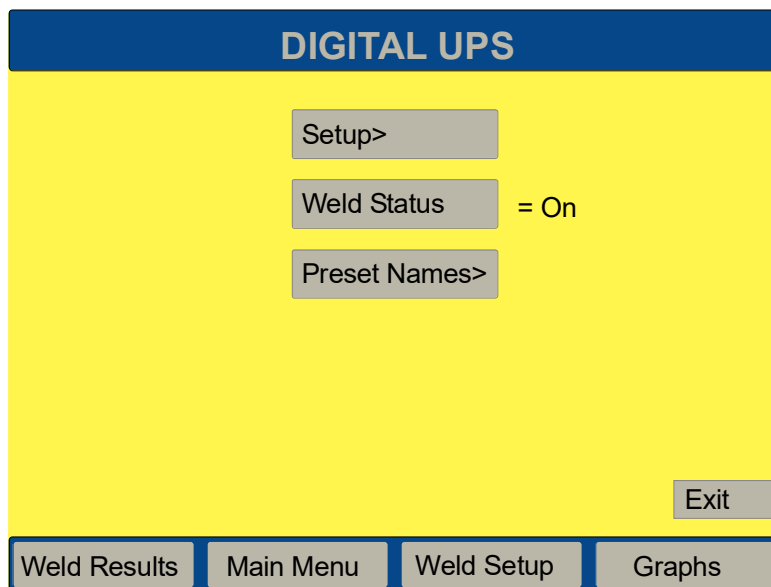

From the Setup navigation button, you can toggle to turn either Memory or Timed Seek On or Off.

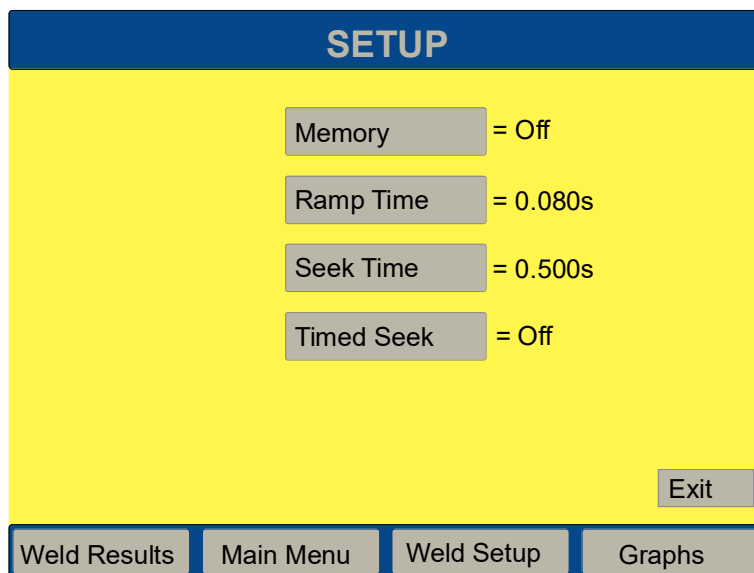

The following keypad screens are accessed by touching the Ramp Time or Seek Time navigation button.

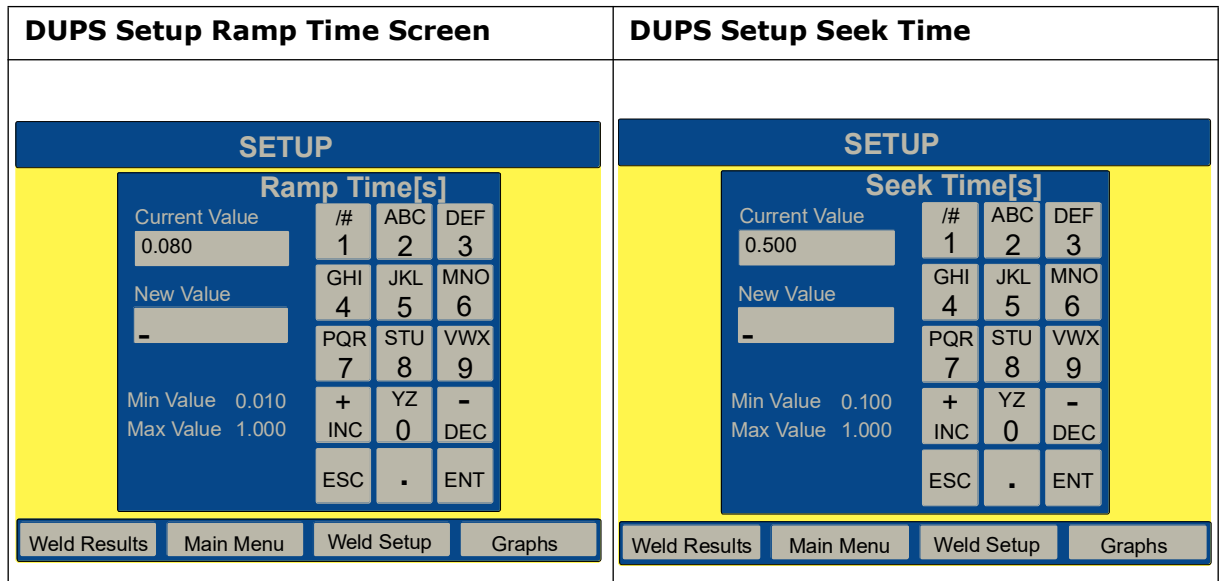

When the Weld Status button is toggled Off, you can view Time, Peak Power and Frequency Change alarms accessed in the Weld Results screen by touching the alarm field display in the upper left corner. When the Weld Status button is toggled On, additional alarms unique to the DUPS can be accessed in the Weld Results screen by touching the alarm field display in the upper left corner. The Current O/L screen will show Phase/Pwr, Frequency and Voltage Touching the Preset Names navigation button allows you to view Presets.

6.7.2.10 Post Weld Seek

You can select Post Weld Seek. Post Weld Seek operates the stack at a low-level (5%) amplitude immediately after the weld cycle afterburst, so the Power Supply can determine the current operating frequency of the stack. The Post Weld Seek screen allows you to turn this feature On or Off.

6.7.2.11 Frequency Offset

You can select whether to use a Frequency Offset. If you select ON, you must also set the offset (in Hz), which the 2000X will apply to the frequency value at the trigger point stored in the Power Supply.

The following screens display the navigation button and keypad for entering this value.

| Frequency Offset Navigation Screen | Frequency Offset Keypad |
|------------------------------------|-------------------------|
| | |

6.7.2.12 Act Clr Output

You can set an output from the user I/O board to become active at a set distance from the Home position. The set value ensures that indexing equipment will not contact the Horn after welding. Touch the navigation button in the Actuator Clear Output screen to access the numeric keypad. Enter the desired value and Enter.

| Actuator Clear Output Navigation Screen | Actuator Clear Output Keypad |
|---|------------------------------|
| | |

6.7.2.13 Cycle Aborts

You can select whether to abort any cycle based on certain input conditions. You can set the Ground Detect Cutoff to ON or OFF (to indicate whether to abort the cycle if the horn contacts the electrically isolated fixture or anvil), and set Missing Part to ON or OFF (to indicate whether to abort the cycle if a part is not in the fixture). If you have set Missing Part to ON, you will access respective keypads to set Maximum and Minimum missing part distances. A missing part output can also be defined in the User I/O. Any cycle-abort conditions will generate an alarm and terminate the cycle. The Cycle Aborts navigation screen is shown below.

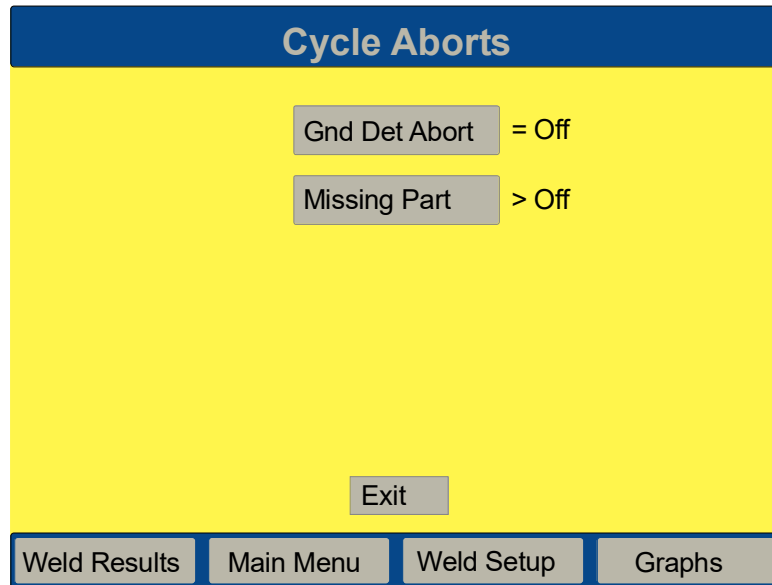

NOTICE



You must have Ground Detect Cable EDP 100-246-630 installed to utilize Ground Detect Cutoff. It connects to the MPS/GDS located on the rear of the actuator to the isolated fixture/ anvil.

Touching the Missing Part navigation button will allow access to the keypad to set and enter Minimum and Maximum values.

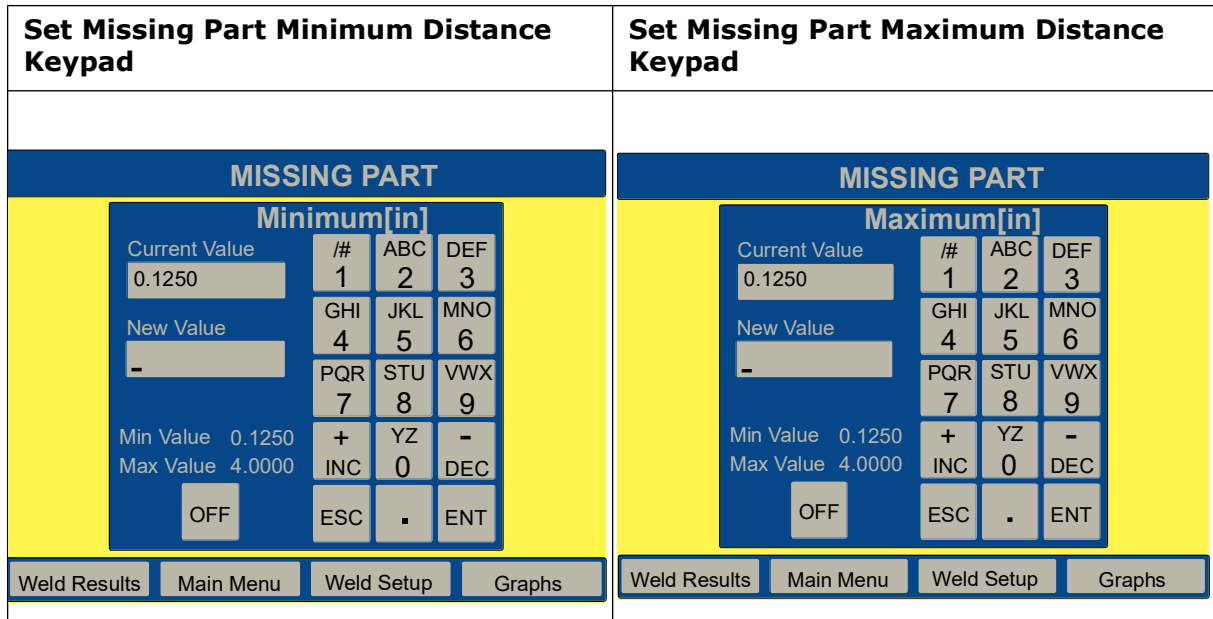

6.7.2.14 Timeout (s)

You select the duration (in seconds) of the maximum allowable time for the primary parameter to be reached during the weld in modes other than time. If the primary parameter has not been reached, the ultrasonic energy will be turned off and the Hold Time will start at the set timeout value. This feature is not available in Time mode. Touching the Timeout navigation button will access the keypad to set and enter the desired value.

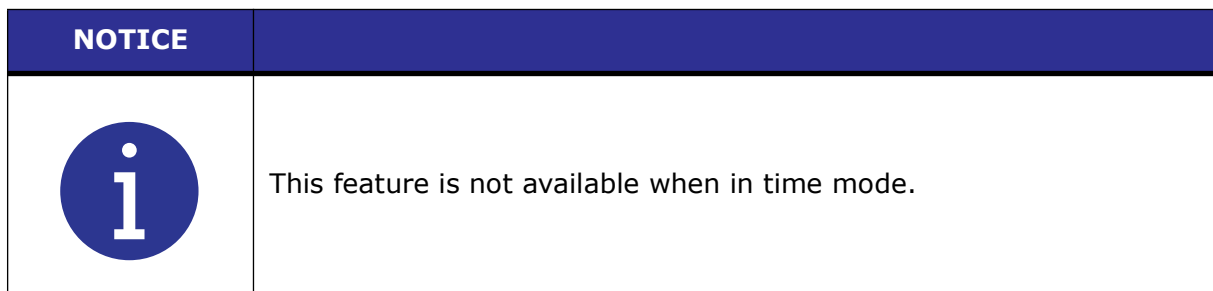

6.7.2.15 Control Limits

You can select whether to use Control Limits. If you select ON, you will set limits of minimum and maximum energy compensation (in Joules), a peak power cutoff (as a percentage of the maximum), an absolute distance (in) measured from the home position, or a collapse distance (in) measured from the trigger. The 2000X uses these Control Limits in addition to the primary weld mode and parameter to determine the end of the welding cycle before moving to the Hold state.

When energy compensation is on and the minimum energy computed value is not reached, the weld time will be extended up to 50% of the Set Weld time value in order to

reach this limit. When the maximum energy computed value is reached, the Weld Time will be terminated and the Hold Time will start.

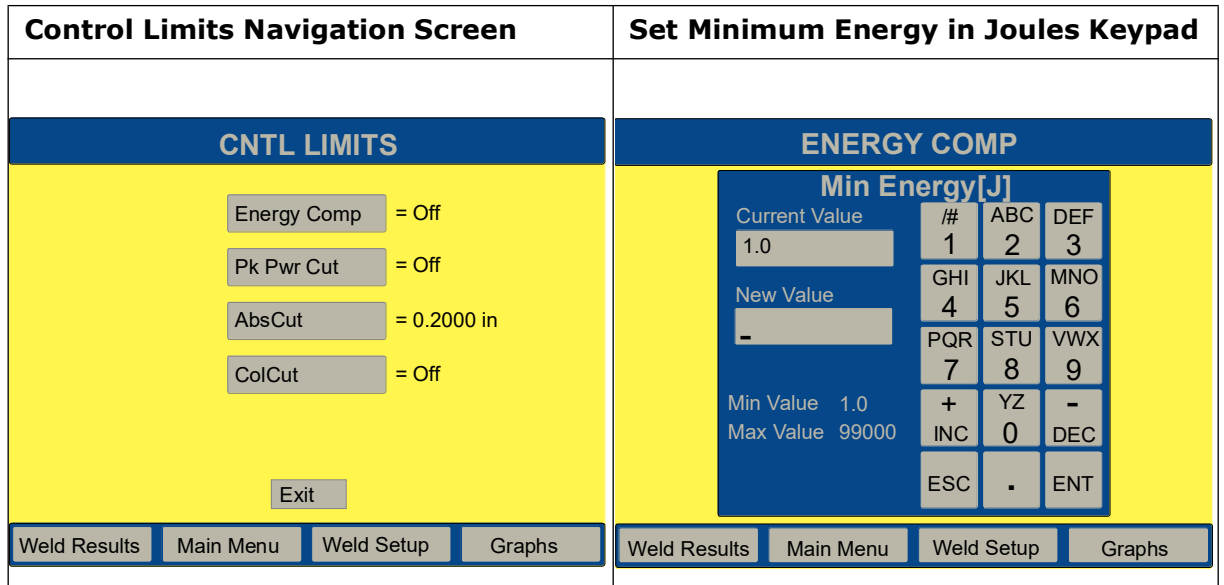

6.7.2.16 Setting Limits

From within any weld mode, you can set the main parameter (indicated by the name of the weld mode) and Hold Time and several other parameters. The other parameters you can set include Suspect Limits and Reject Limits. You can reduce the amount of scrap from unacceptable parts by identifying those parts that are slightly out of range using Suspect and/or Reject Limits. Upon manual inspection, you might find that these parts are acceptable. You can set the Suspect and Reject Limits on the Power Supply to identify (by counter, printed output, or alarm) all parts that fall into limit categories.

For example, consider a weld cycle in Time Weld Mode, where you have set the time to 0.280 second. You have determined (by laboratory testing, trial and error, or some other means) that you get an acceptable weld when 100 to 110 Joules of energy have been transmitted to the part. These are the limits that you should then set on the Power Supply as Suspect Limits. You have also determined that the part is a "reject" if it received fewer than 95 Joules or more than 115 Joules. This is illustrated by the following graph:

You can set Suspect and Reject Limits for meaningful parameters in each weld mode.

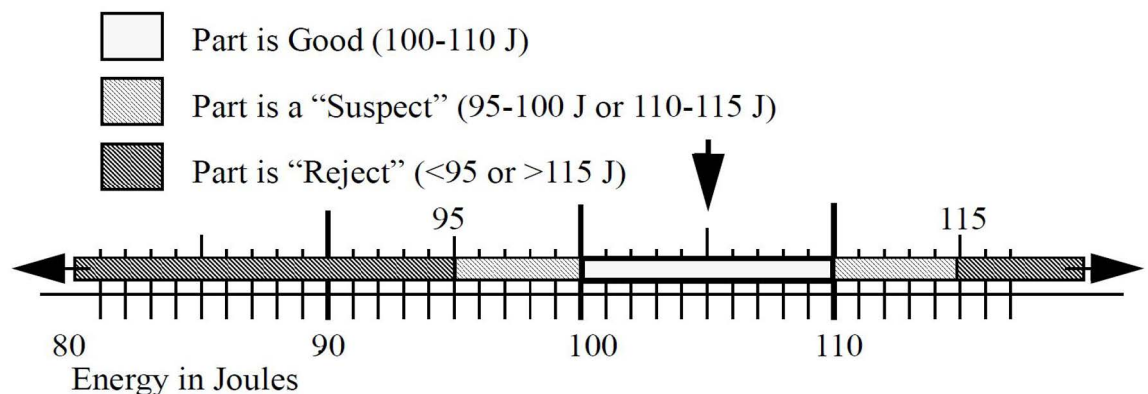

| Set Maximum Energy in Joules Keypad | Set Peak Power Cutoff as %/W of Max. Keypad | | | | | | | | | | | | | | | | | | | | | | | | | | | | | | | | | | | | | | | | | | | | | | | | | | | | | | | | | | | | | | | | | | | | | | | | | | | | | | | | | | | | | | | | | | | | |
|--|--|-----|-----|--|---------------|--|--|--|---------------|---|-----|-----|-----|---|---|---|-----------|-----|-----|-----|---|---|---|---|--|-----|-----|-----|--|---|---|---|---------------|---|----|---|-----------------|-----|---|-----|--|-----|---|-----|--|-------------|--|--|--|---------------|--|--|--|---------------|---|-----|-----|-----|---|---|---|-----------|-----|-----|-----|---|---|---|---|--|-----|-----|-----|--|---|---|---|---------------|---|----|---|-----------------|-----|---|-----|--|-----|---|-----|--|-----|--|--|
| <div style="border: 1px solid black; padding: 5px;"> <table border="1" style="width: 100%; background-color: #e6f2ff;"> <tr> <th colspan="4" style="text-align: center;">ENERGY COMP</th> </tr> <tr> <th colspan="4" style="text-align: center;">Max Energy[J]</th> </tr> <tr> <td>Current Value</td> <td>#</td> <td>ABC</td> <td>DEF</td> </tr> <tr> <td>1.0</td> <td>1</td> <td>2</td> <td>3</td> </tr> <tr> <td>New Value</td> <td>GHI</td> <td>JKL</td> <td>MNO</td> </tr> <tr> <td>-</td> <td>4</td> <td>5</td> <td>6</td> </tr> <tr> <td></td> <td>PQR</td> <td>STU</td> <td>VWX</td> </tr> <tr> <td></td> <td>7</td> <td>8</td> <td>9</td> </tr> <tr> <td>Min Value 1.0</td> <td>+</td> <td>YZ</td> <td>-</td> </tr> <tr> <td>Max Value 33000</td> <td>INC</td> <td>0</td> <td>DEC</td> </tr> <tr> <td></td> <td>ESC</td> <td>.</td> <td>ENT</td> </tr> </table> </div> | ENERGY COMP | | | | Max Energy[J] | | | | Current Value | # | ABC | DEF | 1.0 | 1 | 2 | 3 | New Value | GHI | JKL | MNO | - | 4 | 5 | 6 | | PQR | STU | VWX | | 7 | 8 | 9 | Min Value 1.0 | + | YZ | - | Max Value 33000 | INC | 0 | DEC | | ESC | . | ENT | <div style="border: 1px solid black; padding: 5px;"> <table border="1" style="width: 100%; background-color: #e6f2ff;"> <tr> <th colspan="4" style="text-align: center;">CNTL LIMITS</th> </tr> <tr> <th colspan="4" style="text-align: center;">Pk Pwr Cut[%]</th> </tr> <tr> <td>Current Value</td> <td>#</td> <td>ABC</td> <td>DEF</td> </tr> <tr> <td>1.0</td> <td>1</td> <td>2</td> <td>3</td> </tr> <tr> <td>New Value</td> <td>GHI</td> <td>JKL</td> <td>MNO</td> </tr> <tr> <td>-</td> <td>4</td> <td>5</td> <td>6</td> </tr> <tr> <td></td> <td>PQR</td> <td>STU</td> <td>VWX</td> </tr> <tr> <td></td> <td>7</td> <td>8</td> <td>9</td> </tr> <tr> <td>Min Value 1.0</td> <td>+</td> <td>YZ</td> <td>-</td> </tr> <tr> <td>Max Value 100.0</td> <td>INC</td> <td>0</td> <td>DEC</td> </tr> <tr> <td></td> <td>ESC</td> <td>.</td> <td>ENT</td> </tr> <tr> <td></td> <td>OFF</td> <td></td> <td></td> </tr> </table> </div> | CNTL LIMITS | | | | Pk Pwr Cut[%] | | | | Current Value | # | ABC | DEF | 1.0 | 1 | 2 | 3 | New Value | GHI | JKL | MNO | - | 4 | 5 | 6 | | PQR | STU | VWX | | 7 | 8 | 9 | Min Value 1.0 | + | YZ | - | Max Value 100.0 | INC | 0 | DEC | | ESC | . | ENT | | OFF | | |
| ENERGY COMP | | | | | | | | | | | | | | | | | | | | | | | | | | | | | | | | | | | | | | | | | | | | | | | | | | | | | | | | | | | | | | | | | | | | | | | | | | | | | | | | | | | | | | | | | | | | | |
| Max Energy[J] | | | | | | | | | | | | | | | | | | | | | | | | | | | | | | | | | | | | | | | | | | | | | | | | | | | | | | | | | | | | | | | | | | | | | | | | | | | | | | | | | | | | | | | | | | | | | |
| Current Value | # | ABC | DEF | | | | | | | | | | | | | | | | | | | | | | | | | | | | | | | | | | | | | | | | | | | | | | | | | | | | | | | | | | | | | | | | | | | | | | | | | | | | | | | | | | | | | | | | | | |
| 1.0 | 1 | 2 | 3 | | | | | | | | | | | | | | | | | | | | | | | | | | | | | | | | | | | | | | | | | | | | | | | | | | | | | | | | | | | | | | | | | | | | | | | | | | | | | | | | | | | | | | | | | | |
| New Value | GHI | JKL | MNO | | | | | | | | | | | | | | | | | | | | | | | | | | | | | | | | | | | | | | | | | | | | | | | | | | | | | | | | | | | | | | | | | | | | | | | | | | | | | | | | | | | | | | | | | | |
| - | 4 | 5 | 6 | | | | | | | | | | | | | | | | | | | | | | | | | | | | | | | | | | | | | | | | | | | | | | | | | | | | | | | | | | | | | | | | | | | | | | | | | | | | | | | | | | | | | | | | | | |
| | PQR | STU | VWX | | | | | | | | | | | | | | | | | | | | | | | | | | | | | | | | | | | | | | | | | | | | | | | | | | | | | | | | | | | | | | | | | | | | | | | | | | | | | | | | | | | | | | | | | | |
| | 7 | 8 | 9 | | | | | | | | | | | | | | | | | | | | | | | | | | | | | | | | | | | | | | | | | | | | | | | | | | | | | | | | | | | | | | | | | | | | | | | | | | | | | | | | | | | | | | | | | | |
| Min Value 1.0 | + | YZ | - | | | | | | | | | | | | | | | | | | | | | | | | | | | | | | | | | | | | | | | | | | | | | | | | | | | | | | | | | | | | | | | | | | | | | | | | | | | | | | | | | | | | | | | | | | |
| Max Value 33000 | INC | 0 | DEC | | | | | | | | | | | | | | | | | | | | | | | | | | | | | | | | | | | | | | | | | | | | | | | | | | | | | | | | | | | | | | | | | | | | | | | | | | | | | | | | | | | | | | | | | | |
| | ESC | . | ENT | | | | | | | | | | | | | | | | | | | | | | | | | | | | | | | | | | | | | | | | | | | | | | | | | | | | | | | | | | | | | | | | | | | | | | | | | | | | | | | | | | | | | | | | | | |
| CNTL LIMITS | | | | | | | | | | | | | | | | | | | | | | | | | | | | | | | | | | | | | | | | | | | | | | | | | | | | | | | | | | | | | | | | | | | | | | | | | | | | | | | | | | | | | | | | | | | | | |
| Pk Pwr Cut[%] | | | | | | | | | | | | | | | | | | | | | | | | | | | | | | | | | | | | | | | | | | | | | | | | | | | | | | | | | | | | | | | | | | | | | | | | | | | | | | | | | | | | | | | | | | | | | |
| Current Value | # | ABC | DEF | | | | | | | | | | | | | | | | | | | | | | | | | | | | | | | | | | | | | | | | | | | | | | | | | | | | | | | | | | | | | | | | | | | | | | | | | | | | | | | | | | | | | | | | | | |
| 1.0 | 1 | 2 | 3 | | | | | | | | | | | | | | | | | | | | | | | | | | | | | | | | | | | | | | | | | | | | | | | | | | | | | | | | | | | | | | | | | | | | | | | | | | | | | | | | | | | | | | | | | | |
| New Value | GHI | JKL | MNO | | | | | | | | | | | | | | | | | | | | | | | | | | | | | | | | | | | | | | | | | | | | | | | | | | | | | | | | | | | | | | | | | | | | | | | | | | | | | | | | | | | | | | | | | | |
| - | 4 | 5 | 6 | | | | | | | | | | | | | | | | | | | | | | | | | | | | | | | | | | | | | | | | | | | | | | | | | | | | | | | | | | | | | | | | | | | | | | | | | | | | | | | | | | | | | | | | | | |
| | PQR | STU | VWX | | | | | | | | | | | | | | | | | | | | | | | | | | | | | | | | | | | | | | | | | | | | | | | | | | | | | | | | | | | | | | | | | | | | | | | | | | | | | | | | | | | | | | | | | | |
| | 7 | 8 | 9 | | | | | | | | | | | | | | | | | | | | | | | | | | | | | | | | | | | | | | | | | | | | | | | | | | | | | | | | | | | | | | | | | | | | | | | | | | | | | | | | | | | | | | | | | | |
| Min Value 1.0 | + | YZ | - | | | | | | | | | | | | | | | | | | | | | | | | | | | | | | | | | | | | | | | | | | | | | | | | | | | | | | | | | | | | | | | | | | | | | | | | | | | | | | | | | | | | | | | | | | |
| Max Value 100.0 | INC | 0 | DEC | | | | | | | | | | | | | | | | | | | | | | | | | | | | | | | | | | | | | | | | | | | | | | | | | | | | | | | | | | | | | | | | | | | | | | | | | | | | | | | | | | | | | | | | | | |
| | ESC | . | ENT | | | | | | | | | | | | | | | | | | | | | | | | | | | | | | | | | | | | | | | | | | | | | | | | | | | | | | | | | | | | | | | | | | | | | | | | | | | | | | | | | | | | | | | | | | |
| | OFF | | | | | | | | | | | | | | | | | | | | | | | | | | | | | | | | | | | | | | | | | | | | | | | | | | | | | | | | | | | | | | | | | | | | | | | | | | | | | | | | | | | | | | | | | | | | |
| <div style="border: 1px solid black; padding: 2px;"> Weld Results Main Menu Weld Setup Graphs </div> | <div style="border: 1px solid black; padding: 2px;"> Weld Results Main Menu Weld Setup Graphs </div> | | | | | | | | | | | | | | | | | | | | | | | | | | | | | | | | | | | | | | | | | | | | | | | | | | | | | | | | | | | | | | | | | | | | | | | | | | | | | | | | | | | | | | | | | | | | |

| Set Absolute Cutoff Distance Keypad | Set Collapse Cutoff Distance Keypad | | | | | | | | | | | | | | | | | | | | | | | | | | | | | | | | | | | | | | | | | | | | | | | | | | | | | | | | | | | | | | | | | | | | | | | | | | | | | | | | | | | | | | | | | | | | | | | | |
|--|--|-----|-----|--|------------|--|--|--|---------------|---|-----|-----|--------|---|---|---|-----------|-----|-----|-----|---|---|---|---|--|-----|-----|-----|--|---|---|---|------------------|---|----|---|------------------|-----|---|-----|--|-----|---|-----|--|-----|--|--|--|-------------|--|--|--|------------|--|--|--|---------------|---|-----|-----|--------|---|---|---|-----------|-----|-----|-----|---|---|---|---|--|-----|-----|-----|--|---|---|---|------------------|---|----|---|------------------|-----|---|-----|--|-----|---|-----|--|-----|--|--|
| <div style="border: 1px solid black; padding: 5px;"> <table border="1" style="width: 100%; background-color: #e6f2ff;"> <tr> <th colspan="4" style="text-align: center;">CNTL LIMITS</th> </tr> <tr> <th colspan="4" style="text-align: center;">AbsCut[in]</th> </tr> <tr> <td>Current Value</td> <td>#</td> <td>ABC</td> <td>DEF</td> </tr> <tr> <td>0.2000</td> <td>1</td> <td>2</td> <td>3</td> </tr> <tr> <td>New Value</td> <td>GHI</td> <td>JKL</td> <td>MNO</td> </tr> <tr> <td>-</td> <td>4</td> <td>5</td> <td>6</td> </tr> <tr> <td></td> <td>PQR</td> <td>STU</td> <td>VWX</td> </tr> <tr> <td></td> <td>7</td> <td>8</td> <td>9</td> </tr> <tr> <td>Min Value 0.1250</td> <td>+</td> <td>YZ</td> <td>-</td> </tr> <tr> <td>Max Value 4.0000</td> <td>INC</td> <td>0</td> <td>DEC</td> </tr> <tr> <td></td> <td>ESC</td> <td>.</td> <td>ENT</td> </tr> <tr> <td></td> <td>OFF</td> <td></td> <td></td> </tr> </table> </div> | CNTL LIMITS | | | | AbsCut[in] | | | | Current Value | # | ABC | DEF | 0.2000 | 1 | 2 | 3 | New Value | GHI | JKL | MNO | - | 4 | 5 | 6 | | PQR | STU | VWX | | 7 | 8 | 9 | Min Value 0.1250 | + | YZ | - | Max Value 4.0000 | INC | 0 | DEC | | ESC | . | ENT | | OFF | | | <div style="border: 1px solid black; padding: 5px;"> <table border="1" style="width: 100%; background-color: #e6f2ff;"> <tr> <th colspan="4" style="text-align: center;">CNTL LIMITS</th> </tr> <tr> <th colspan="4" style="text-align: center;">ColCut[in]</th> </tr> <tr> <td>Current Value</td> <td>#</td> <td>ABC</td> <td>DEF</td> </tr> <tr> <td>0.0004</td> <td>1</td> <td>2</td> <td>3</td> </tr> <tr> <td>New Value</td> <td>GHI</td> <td>JKL</td> <td>MNO</td> </tr> <tr> <td>-</td> <td>4</td> <td>5</td> <td>6</td> </tr> <tr> <td></td> <td>PQR</td> <td>STU</td> <td>VWX</td> </tr> <tr> <td></td> <td>7</td> <td>8</td> <td>9</td> </tr> <tr> <td>Min Value 0.0004</td> <td>+</td> <td>YZ</td> <td>-</td> </tr> <tr> <td>Max Value 1.0000</td> <td>INC</td> <td>0</td> <td>DEC</td> </tr> <tr> <td></td> <td>ESC</td> <td>.</td> <td>ENT</td> </tr> <tr> <td></td> <td>OFF</td> <td></td> <td></td> </tr> </table> </div> | CNTL LIMITS | | | | ColCut[in] | | | | Current Value | # | ABC | DEF | 0.0004 | 1 | 2 | 3 | New Value | GHI | JKL | MNO | - | 4 | 5 | 6 | | PQR | STU | VWX | | 7 | 8 | 9 | Min Value 0.0004 | + | YZ | - | Max Value 1.0000 | INC | 0 | DEC | | ESC | . | ENT | | OFF | | |
| CNTL LIMITS | | | | | | | | | | | | | | | | | | | | | | | | | | | | | | | | | | | | | | | | | | | | | | | | | | | | | | | | | | | | | | | | | | | | | | | | | | | | | | | | | | | | | | | | | | | | | | | | | |
| AbsCut[in] | | | | | | | | | | | | | | | | | | | | | | | | | | | | | | | | | | | | | | | | | | | | | | | | | | | | | | | | | | | | | | | | | | | | | | | | | | | | | | | | | | | | | | | | | | | | | | | | | |
| Current Value | # | ABC | DEF | | | | | | | | | | | | | | | | | | | | | | | | | | | | | | | | | | | | | | | | | | | | | | | | | | | | | | | | | | | | | | | | | | | | | | | | | | | | | | | | | | | | | | | | | | | | | | |
| 0.2000 | 1 | 2 | 3 | | | | | | | | | | | | | | | | | | | | | | | | | | | | | | | | | | | | | | | | | | | | | | | | | | | | | | | | | | | | | | | | | | | | | | | | | | | | | | | | | | | | | | | | | | | | | | |
| New Value | GHI | JKL | MNO | | | | | | | | | | | | | | | | | | | | | | | | | | | | | | | | | | | | | | | | | | | | | | | | | | | | | | | | | | | | | | | | | | | | | | | | | | | | | | | | | | | | | | | | | | | | | | |
| - | 4 | 5 | 6 | | | | | | | | | | | | | | | | | | | | | | | | | | | | | | | | | | | | | | | | | | | | | | | | | | | | | | | | | | | | | | | | | | | | | | | | | | | | | | | | | | | | | | | | | | | | | | |
| | PQR | STU | VWX | | | | | | | | | | | | | | | | | | | | | | | | | | | | | | | | | | | | | | | | | | | | | | | | | | | | | | | | | | | | | | | | | | | | | | | | | | | | | | | | | | | | | | | | | | | | | | |
| | 7 | 8 | 9 | | | | | | | | | | | | | | | | | | | | | | | | | | | | | | | | | | | | | | | | | | | | | | | | | | | | | | | | | | | | | | | | | | | | | | | | | | | | | | | | | | | | | | | | | | | | | | |
| Min Value 0.1250 | + | YZ | - | | | | | | | | | | | | | | | | | | | | | | | | | | | | | | | | | | | | | | | | | | | | | | | | | | | | | | | | | | | | | | | | | | | | | | | | | | | | | | | | | | | | | | | | | | | | | | |
| Max Value 4.0000 | INC | 0 | DEC | | | | | | | | | | | | | | | | | | | | | | | | | | | | | | | | | | | | | | | | | | | | | | | | | | | | | | | | | | | | | | | | | | | | | | | | | | | | | | | | | | | | | | | | | | | | | | |
| | ESC | . | ENT | | | | | | | | | | | | | | | | | | | | | | | | | | | | | | | | | | | | | | | | | | | | | | | | | | | | | | | | | | | | | | | | | | | | | | | | | | | | | | | | | | | | | | | | | | | | | | |
| | OFF | | | | | | | | | | | | | | | | | | | | | | | | | | | | | | | | | | | | | | | | | | | | | | | | | | | | | | | | | | | | | | | | | | | | | | | | | | | | | | | | | | | | | | | | | | | | | | | | |
| CNTL LIMITS | | | | | | | | | | | | | | | | | | | | | | | | | | | | | | | | | | | | | | | | | | | | | | | | | | | | | | | | | | | | | | | | | | | | | | | | | | | | | | | | | | | | | | | | | | | | | | | | | |
| ColCut[in] | | | | | | | | | | | | | | | | | | | | | | | | | | | | | | | | | | | | | | | | | | | | | | | | | | | | | | | | | | | | | | | | | | | | | | | | | | | | | | | | | | | | | | | | | | | | | | | | | |
| Current Value | # | ABC | DEF | | | | | | | | | | | | | | | | | | | | | | | | | | | | | | | | | | | | | | | | | | | | | | | | | | | | | | | | | | | | | | | | | | | | | | | | | | | | | | | | | | | | | | | | | | | | | | |
| 0.0004 | 1 | 2 | 3 | | | | | | | | | | | | | | | | | | | | | | | | | | | | | | | | | | | | | | | | | | | | | | | | | | | | | | | | | | | | | | | | | | | | | | | | | | | | | | | | | | | | | | | | | | | | | | |
| New Value | GHI | JKL | MNO | | | | | | | | | | | | | | | | | | | | | | | | | | | | | | | | | | | | | | | | | | | | | | | | | | | | | | | | | | | | | | | | | | | | | | | | | | | | | | | | | | | | | | | | | | | | | | |
| - | 4 | 5 | 6 | | | | | | | | | | | | | | | | | | | | | | | | | | | | | | | | | | | | | | | | | | | | | | | | | | | | | | | | | | | | | | | | | | | | | | | | | | | | | | | | | | | | | | | | | | | | | | |
| | PQR | STU | VWX | | | | | | | | | | | | | | | | | | | | | | | | | | | | | | | | | | | | | | | | | | | | | | | | | | | | | | | | | | | | | | | | | | | | | | | | | | | | | | | | | | | | | | | | | | | | | | |
| | 7 | 8 | 9 | | | | | | | | | | | | | | | | | | | | | | | | | | | | | | | | | | | | | | | | | | | | | | | | | | | | | | | | | | | | | | | | | | | | | | | | | | | | | | | | | | | | | | | | | | | | | | |
| Min Value 0.0004 | + | YZ | - | | | | | | | | | | | | | | | | | | | | | | | | | | | | | | | | | | | | | | | | | | | | | | | | | | | | | | | | | | | | | | | | | | | | | | | | | | | | | | | | | | | | | | | | | | | | | | |
| Max Value 1.0000 | INC | 0 | DEC | | | | | | | | | | | | | | | | | | | | | | | | | | | | | | | | | | | | | | | | | | | | | | | | | | | | | | | | | | | | | | | | | | | | | | | | | | | | | | | | | | | | | | | | | | | | | | |
| | ESC | . | ENT | | | | | | | | | | | | | | | | | | | | | | | | | | | | | | | | | | | | | | | | | | | | | | | | | | | | | | | | | | | | | | | | | | | | | | | | | | | | | | | | | | | | | | | | | | | | | | |
| | OFF | | | | | | | | | | | | | | | | | | | | | | | | | | | | | | | | | | | | | | | | | | | | | | | | | | | | | | | | | | | | | | | | | | | | | | | | | | | | | | | | | | | | | | | | | | | | | | | | |
| <div style="border: 1px solid black; padding: 2px;"> Weld Results Main Menu Weld Setup Graphs </div> | <div style="border: 1px solid black; padding: 2px;"> Weld Results Main Menu Weld Setup Graphs </div> | | | | | | | | | | | | | | | | | | | | | | | | | | | | | | | | | | | | | | | | | | | | | | | | | | | | | | | | | | | | | | | | | | | | | | | | | | | | | | | | | | | | | | | | | | | | | | | | |

6.7.2.17 Suspect Limits

You can select whether to use Suspect Limits to indicate that a part might not have a good weld. You can set limits of minimum and maximum time allowed for the weld, energy levels (in Joules), peak power levels (as a percentage of the maximum), collapse distance (in inches), and absolute distance (in inches). If you set Reset Required to YES, when an alarm is generated, you will need to press the Reset key prior to welding another part.

6.7.2.18 Reject Limits

You can select whether to use Reject Limits to indicate that a part does not have a good weld. You can set limits of minimum and maximum time for the weld (in seconds), energy

levels (in Joules), peak power levels (as a percentage of the maximum), collapse distance (in inches), and absolute distance (in inches) and/or frequency (in Hz). If you set Reset Required to YES, when an alarm is generated, you will need to press the Reset key prior to welding another part.

Suspect and Reject value limits are identical, and can be viewed in [Table 6.4 Suspect and Reject Parameter Value Range](#). Each parameter's navigation button will access its respective keypad for setting and entering limits.

Suspect and Reject limits put out a signal to pins 20 and 5 of J3 respectively. The 44 pin I/O cable J957 connects to J3.

6.7.2.19 Afterburst

You can select whether there will be a burst of ultrasonic energy after welding is complete. If you select ON, you can also set the delay and length of the afterburst (in seconds), and the amplitude that will be used.

| Afterburst Navigation Screen | Afterburst Delay Screen | | | | | | | | | | | | | | | | | | | | | | | | | | | |
|---|---|-----|-----|-----|---|---|---|-----|-----|-----|---|---|---|-----|-----|-----|---|---|---|---|----|---|-----|---|-----|-----|---|-----|
| <p>AFTERBURST</p> <p>AB Delay = 0.100 s</p> <p>AB Time = 100%</p> <p>AB Amplitude = 100%</p> <p>Exit</p> <p>Weld Results Main Menu Weld Setup Graphs</p> | <p>Afterburst</p> <p>AB Delay[s]</p> <p>Current Value 0.100</p> <p>New Value -</p> <p>Min Value 0.100</p> <p>Max Value 2.000</p> <table border="1"> <tr><td>#</td><td>ABC</td><td>DEF</td></tr> <tr><td>1</td><td>2</td><td>3</td></tr> <tr><td>GHI</td><td>JKL</td><td>MNO</td></tr> <tr><td>4</td><td>5</td><td>6</td></tr> <tr><td>PQR</td><td>STU</td><td>VWX</td></tr> <tr><td>7</td><td>8</td><td>9</td></tr> <tr><td>+</td><td>YZ</td><td>-</td></tr> <tr><td>INC</td><td>0</td><td>DEC</td></tr> <tr><td>ESC</td><td>.</td><td>ENT</td></tr> </table> <p>Weld Results Main Menu Weld Setup Graphs</p> | # | ABC | DEF | 1 | 2 | 3 | GHI | JKL | MNO | 4 | 5 | 6 | PQR | STU | VWX | 7 | 8 | 9 | + | YZ | - | INC | 0 | DEC | ESC | . | ENT |
| # | ABC | DEF | | | | | | | | | | | | | | | | | | | | | | | | | | |
| 1 | 2 | 3 | | | | | | | | | | | | | | | | | | | | | | | | | | |
| GHI | JKL | MNO | | | | | | | | | | | | | | | | | | | | | | | | | | |
| 4 | 5 | 6 | | | | | | | | | | | | | | | | | | | | | | | | | | |
| PQR | STU | VWX | | | | | | | | | | | | | | | | | | | | | | | | | | |
| 7 | 8 | 9 | | | | | | | | | | | | | | | | | | | | | | | | | | |
| + | YZ | - | | | | | | | | | | | | | | | | | | | | | | | | | | |
| INC | 0 | DEC | | | | | | | | | | | | | | | | | | | | | | | | | | |
| ESC | . | ENT | | | | | | | | | | | | | | | | | | | | | | | | | | |

| Afterburst Time Screen | Afterburst Amplitude% Screen | | | | | | | | | | | | | | | | | | | | | | | | | | | | | | | | | | | | | | | | | | | | | | | | | | | | | | |
|--|------------------------------|-----|-----|---|---|---|-----|-----|-----|---|---|---|-----|-----|-----|---|---|---|---|----|---|-----|---|-----|-----|---|-----|--|---|-----|-----|---|---|---|-----|-----|-----|---|---|---|-----|-----|-----|---|---|---|---|----|---|-----|---|-----|-----|---|-----|
| <p>Afterburst</p> <p>AB Time[s]</p> <p>Current Value 0.100</p> <p>New Value -</p> <p>Min Value 0.100</p> <p>Max Value 2.000</p> <table border="1"> <tr><td>#</td><td>ABC</td><td>DEF</td></tr> <tr><td>1</td><td>2</td><td>3</td></tr> <tr><td>GHI</td><td>JKL</td><td>MNO</td></tr> <tr><td>4</td><td>5</td><td>6</td></tr> <tr><td>PQR</td><td>STU</td><td>VWX</td></tr> <tr><td>7</td><td>8</td><td>9</td></tr> <tr><td>+</td><td>YZ</td><td>-</td></tr> <tr><td>INC</td><td>0</td><td>DEC</td></tr> <tr><td>ESC</td><td>.</td><td>ENT</td></tr> </table> <p>Weld Results Main Menu Weld Setup Graphs</p> | # | ABC | DEF | 1 | 2 | 3 | GHI | JKL | MNO | 4 | 5 | 6 | PQR | STU | VWX | 7 | 8 | 9 | + | YZ | - | INC | 0 | DEC | ESC | . | ENT | <p>Afterburst</p> <p>AB Amplitude[%]</p> <p>Current Value 100</p> <p>New Value -</p> <p>Min Value 10</p> <p>Max Value 100</p> <table border="1"> <tr><td>#</td><td>ABC</td><td>DEF</td></tr> <tr><td>1</td><td>2</td><td>3</td></tr> <tr><td>GHI</td><td>JKL</td><td>MNO</td></tr> <tr><td>4</td><td>5</td><td>6</td></tr> <tr><td>PQR</td><td>STU</td><td>VWX</td></tr> <tr><td>7</td><td>8</td><td>9</td></tr> <tr><td>+</td><td>YZ</td><td>-</td></tr> <tr><td>INC</td><td>0</td><td>DEC</td></tr> <tr><td>ESC</td><td>.</td><td>ENT</td></tr> </table> <p>Weld Results Main Menu Weld Setup Graphs</p> | # | ABC | DEF | 1 | 2 | 3 | GHI | JKL | MNO | 4 | 5 | 6 | PQR | STU | VWX | 7 | 8 | 9 | + | YZ | - | INC | 0 | DEC | ESC | . | ENT |
| # | ABC | DEF | | | | | | | | | | | | | | | | | | | | | | | | | | | | | | | | | | | | | | | | | | | | | | | | | | | | | |
| 1 | 2 | 3 | | | | | | | | | | | | | | | | | | | | | | | | | | | | | | | | | | | | | | | | | | | | | | | | | | | | | |
| GHI | JKL | MNO | | | | | | | | | | | | | | | | | | | | | | | | | | | | | | | | | | | | | | | | | | | | | | | | | | | | | |
| 4 | 5 | 6 | | | | | | | | | | | | | | | | | | | | | | | | | | | | | | | | | | | | | | | | | | | | | | | | | | | | | |
| PQR | STU | VWX | | | | | | | | | | | | | | | | | | | | | | | | | | | | | | | | | | | | | | | | | | | | | | | | | | | | | |
| 7 | 8 | 9 | | | | | | | | | | | | | | | | | | | | | | | | | | | | | | | | | | | | | | | | | | | | | | | | | | | | | |
| + | YZ | - | | | | | | | | | | | | | | | | | | | | | | | | | | | | | | | | | | | | | | | | | | | | | | | | | | | | | |
| INC | 0 | DEC | | | | | | | | | | | | | | | | | | | | | | | | | | | | | | | | | | | | | | | | | | | | | | | | | | | | | |
| ESC | . | ENT | | | | | | | | | | | | | | | | | | | | | | | | | | | | | | | | | | | | | | | | | | | | | | | | | | | | | |
| # | ABC | DEF | | | | | | | | | | | | | | | | | | | | | | | | | | | | | | | | | | | | | | | | | | | | | | | | | | | | | |
| 1 | 2 | 3 | | | | | | | | | | | | | | | | | | | | | | | | | | | | | | | | | | | | | | | | | | | | | | | | | | | | | |
| GHI | JKL | MNO | | | | | | | | | | | | | | | | | | | | | | | | | | | | | | | | | | | | | | | | | | | | | | | | | | | | | |
| 4 | 5 | 6 | | | | | | | | | | | | | | | | | | | | | | | | | | | | | | | | | | | | | | | | | | | | | | | | | | | | | |
| PQR | STU | VWX | | | | | | | | | | | | | | | | | | | | | | | | | | | | | | | | | | | | | | | | | | | | | | | | | | | | | |
| 7 | 8 | 9 | | | | | | | | | | | | | | | | | | | | | | | | | | | | | | | | | | | | | | | | | | | | | | | | | | | | | |
| + | YZ | - | | | | | | | | | | | | | | | | | | | | | | | | | | | | | | | | | | | | | | | | | | | | | | | | | | | | | |
| INC | 0 | DEC | | | | | | | | | | | | | | | | | | | | | | | | | | | | | | | | | | | | | | | | | | | | | | | | | | | | | |
| ESC | . | ENT | | | | | | | | | | | | | | | | | | | | | | | | | | | | | | | | | | | | | | | | | | | | | | | | | | | | | |

Select values using the keypad, within the limits shown in the lower left field, and touch enter.

6.7.2.20 Write In Field

Write In Field provides a means to assign a unique 10 digit alphanumeric to a specific weld setup and cycle.

This is useful for tracking parameter performance relative to a specific welder, and its respective production run.

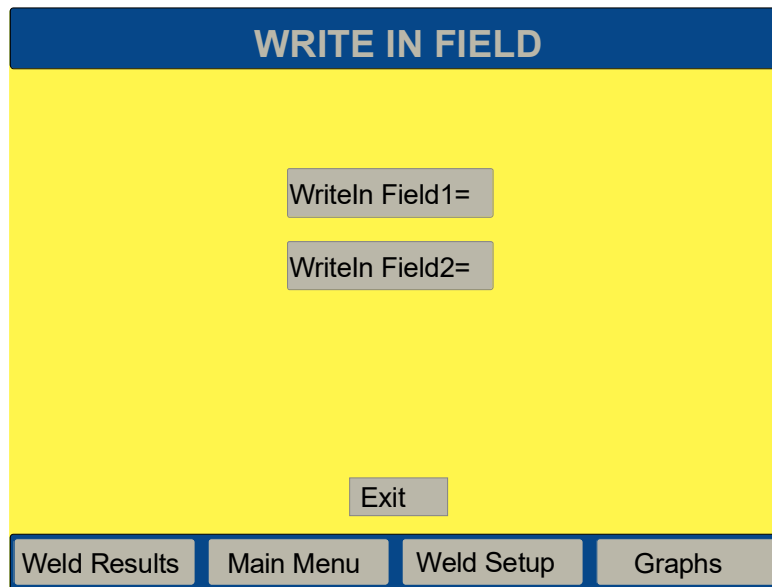

Touching either button will bring up the following screen that allows entry of the alphanumeric to the field.

Each push of a button on the keypad will cycle it through its own unique numeric and the 3 alpha characters associated with the respective numeric.

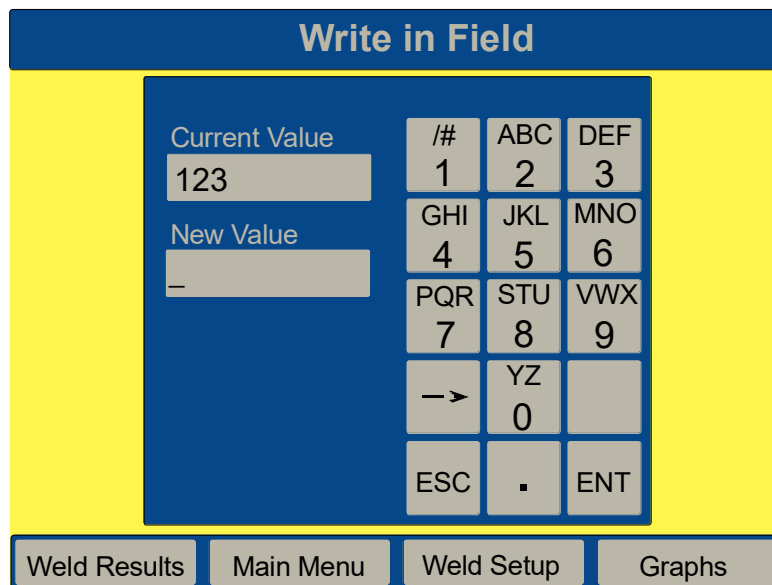

6.7.3 Graphs

Access the View Graphs screen to display the graphs of 6 available parameters: Power, Amplitude, Velocity, Frequency, Force, and Collapse Distance. The Force, Velocity, and Col Distance buttons are only available when an AED actuator is present.

Figure 6.35 Graph Screen

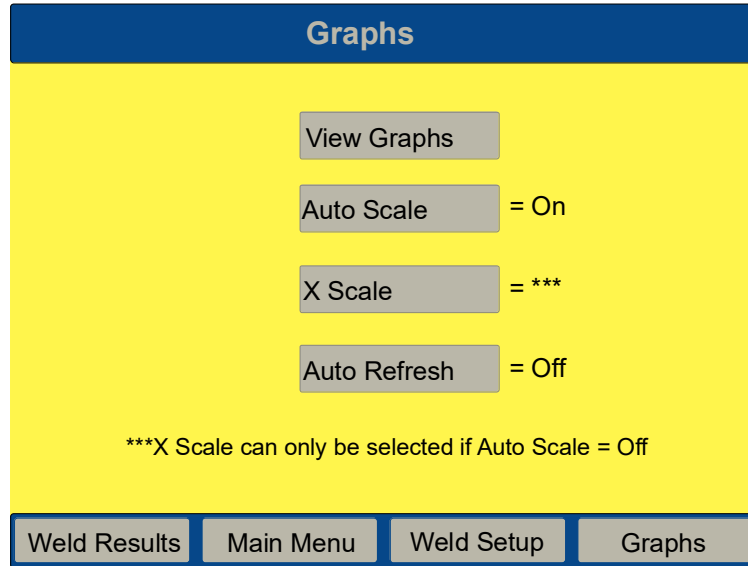

Touching the View Graphs Button will display the following screen:

Figure 6.36 View Graphs Screen

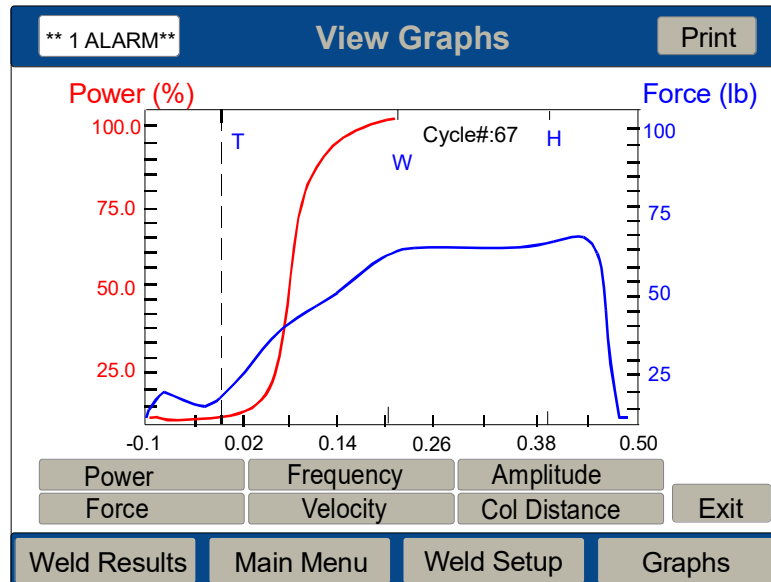

Chapter 7: Maintenance

| | | |
|------------|--|------------|
| 7.1 | 2000X Series Preventive Maintenance | 166 |
| 7.2 | Calibration | 167 |
| 7.3 | Parts Lists | 168 |
| 7.4 | Troubleshooting | 173 |
| 7.5 | System Alarm Tables | 175 |
| 7.6 | Service Events | 221 |
| 7.7 | Parts Replacement | 223 |

7.1 2000X Series Preventive Maintenance

| CAUTION | |
|---|--|
|  | <p>Be certain to disconnect power before performing any maintenance on the power supply or actuator.</p> |

The following preventive measures help assure long term operation of your Branson 2000X Series equipment.

7.1.1 Periodically Clean the Equipment

Air is continuously drawn into the Branson power supply. Periodically disconnect the unit from power, remove the cover and vacuum out any accumulated dust and debris. Remove material adhering to the fan blades and motor, transistors, heat sinks, transformers, circuit boards, cooling intake vents, and exhaust ports. Filters can be added to the power supply cooling fans for dusty environments. External covers may be cleaned with a damp sponge or cloth using a solution of mild soap and water. Do not allow cleaning solution to enter the unit. To prevent rust in areas of high humidity, exposed steel surfaces, such as handles, hardware, and the main column may require a very light film of oil, such as WD-40.

| NOTICE | |
|---|---|
|  | <p>When it is necessary to clean the touch screen, wipe gently with a soft cloth dampened with a mild detergent or Windex. Give a final wipe to the entire screen with the soft damp cloth.</p> <p>Under no circumstances should you use solvents or ammonia to clean the screen. Do not use excessive solution to avoid dripping or seeping into the power supply.</p> |

7.1.2 Reconditioning the Stack (Converter, Booster, and Horn)

Stack components function with greatest efficiency when the mating interface surfaces are in proper condition.

For 15, 20 and 30 kHz products, a Branson Mylar® washer should be installed between the horn and booster and horn and converter. Replace the washer if torn or perforated. Stacks using Mylar washers should be inspected periodically.

Stacks used with silicone grease, as with certain 20 kHz installations and with all 40 kHz products, should be periodically reconditioned to eliminate fretting corrosion. A stack using silicone grease should be inspected periodically for corrosion. When experience is gained for specific stacks, the inspection interval can be adjusted to a longer or shorter period as required. For correct stack interface reconditioning procedures, refer to Chapter 7 of the 2000X and Actuator Instruction Manual.

7.1.3 Routine Component Replacement

The lifetime of certain parts is based on the number of cycles the unit has completed, or on hours of operation, e.g., at 20,000 hours, cooling fans should be replaced.

7.2 Calibration

This product does not normally require scheduled Full System Calibration. However, if you are operating under any type of regulatory requirements, you may need to calibrate the equipment according to that schedule and set of standards. Contact Branson for details.

For standard Actuator calibration, and resetting sensor calibration to factory default settings, refer to Section [6.6.8 Calibration Menu](#).

7.3 Parts Lists

This section provides lists of replacement parts, system cables, and suggested spares.

7.3.1 Replacement Parts

Table 7.1 Replacement Parts List for 2000X distance Power Supply

| Component | EDP Number |
|---|--|
| DC Power Supply Module* | 200-132-294R |
| Line Board* | 100-242-1199R (100-242-1293R for 4 KW units and 15 kHz 3.3 KW & 100-242-1265R for 30 kHz 1.5 KW 120VAC only) |
| System Controller Board* | 102-242-1150R |
| Power Supply Module* | |
| 3.3kW / 15 kHz digital | 100-244-061R |
| 300W / 20 kHz digital | 100-244-138R |
| 1.25kW / 20 kHz digital | 100-244-102R |
| 2.5kW / 20 kHz digital | 100-244-103R |
| 4kW / 20 kHz digital | 159-244-075R |
| 4kW / 20 kHz analog | 159-244-069R |
| 750W / 30 kHz digital | 100-244-104R |
| 1.5kW / 30 kHz digital | 159-244-065R |
| 1.5kW / 30 kHz analog | 100-244-055R |
| 400W / 40 kHz digital | 159-244-064R |
| 800W / 40 kHz digital | 159-244-063R |
| Switch, On / Off; 15A; DPST | 1032510, 1032496 |
| User I/O Board w/ mtg. bracket* | 100-242-1197R |
| Washer, Mylar | |
| Kit 20 kHz, 10 each (1/2 in. and 3/8 in.) | 100-063-357 |
| Kit 20 kHz, 150 each (1/2 in.) | 100-063-471 |
| Kit 20 kHz, 150 each (3/8 in.) | 100-063-472 |
| Kit 30 kHz, 10 each (3/8 in., 30 kHz) | 100-063-632 |
| Fan | 100-126-015R |
| CR2032 Battery for BBRAM | 200-262-003 |
| Cover | 100-032-454 |
| Cover Screws | 200-298-254 (6 ea) and 200-298-044 (1 ea) |

Table 7.1 Replacement Parts List for 2000X distance Power Supply

| Component | EDP Number |
|---|---|
| Line Cord | 100-246-1371 (100-246-1727 for 4 KW units, 15 kHz, 30 kHz 1.5 KW 120VAC only) |
| Miscellaneous | |
| Other parts such as wrenches, silicon grease, studs, etc., are found in Chapter 4: Installation and Setup . | |
| *Each of these items must be replaced as a unit. | |

7.3.2 System Cables

You can order the following cables. If the cable you require is not listed, refer to Section [4.3.1 Cables](#) in [Chapter 4: Installation and Setup](#) of this manual for part number and cable model number.

Table 7.2 2000X-Series System Cables (External)

| P/N | Description | Cable Model |
|-------------|---|-------------|
| 101-241-202 | Cable, Remote Interface 8' to remote pneumatics package (ao actuator) | J924 |
| 101-241-203 | Cable, Actuator Interface 8' | J925S |
| 101-241-204 | Cable, Actuator Interface 15' | J925S |
| 101-241-205 | Cable, Actuator Interface 25' | J925S |
| 101-241-206 | Cable, Actuator Interface 50' | J925S |
| 101-240-020 | Cable, Start 8' | J911 |
| 101-240-015 | Cable, Start 15' | J911 |
| 101-240-010 | Cable, Start 25' | J911 |
| 101-240-168 | Cable, Start 50' | J911 |
| 101-241-207 | Cable, User I/O 8' | J957S |
| 101-241-208 | Cable, User I/O 15' | J957S |
| 101-241-209 | Cable, User I/O 25' | J957S |
| 101-241-258 | Cable, User I/O 50' | J957S |
| 101-240-017 | Cable, RF CR & CJ20 8' | J931S |
| 101-240-012 | Cable, RF CR & CJ20 15' | J931S |
| 101-240-007 | Cable, RF CR & CJ20 25' | J931S |
| 101-240-200 | Cable, RF CR & CJ20 50' | J931 |
| 101-240-176 | Cable, RF CR & CJ20 8' EN | J931CS |

Table 7.2 2000X-Series System Cables (External)

| P/N | Description | Cable Model |
|-------------|----------------------------|-------------|
| 101-240-177 | Cable, RF CR & CJ20 15' EN | J931CS |
| 101-240-178 | Cable, RF CR & CJ20 25' EN | J931CS |
| 101-240-199 | Cable, RF CR & CJ20 50' EN | J931C |
| 100-246-630 | Cable, Ground Detect | - |

| NOTICE | |
|---|--|
|  | <p>Cables identified for 'CJ-20 Converters' are for those Converters when they are installed in Branson 2000X Actuators. The Cable connects to the Actuator.</p> |

7.3.3 Suggested Spares

Table 7.3 Suggested Spares

| Description | EDP# | 1-4 Units | 6-12 Units | 14+ Units |
|--|---------------|-----------|------------|-----------|
| Replacement 2000X Control Board | 102-242-1150R | 0 | 1 | 1 |
| 3.3kW 15 kHz power supply module, digital | 100-244-061R | 0 | 1 | 1 |
| 300W 20 kHz power supply module, digital | 100-244-138R | 0 | 0 | 1 |
| 1.25kW 20 kHz power supply module, digital | 100-244-102R | 0 | 0 | 1 |
| 2.5kW 20 kHz power supply module, digital | 100-244-103R | 0 | 0 | 1 |
| 4kW 20 kHz power supply module, digital | 159-244-075R | 0 | 0 | 1 |
| 4kW 20 kHz power supply module, analog | 159-244-069R | 0 | 1 | 1 |
| 750W 30 kHz power supply module, digital | 100-244-104R | 0 | 0 | 1 |
| 1.5kW 30 kHz power supply module, digital | 159-244-065R | 0 | 0 | 1 |

Table 7.3 Suggested Spares

| Description | EDP# | 1-4 Units | 6-12 Units | 14+ Units |
|--|--|-----------|------------|-----------|
| 1.5kW 30 kHz power supply module, analog | 100-244-055R | 0 | 0 | 1 |
| 400W 40 kHz power supply module, digital | 159-244-064R | 0 | 0 | 1 |
| 800W 40 kHz power supply module, digital | 159-244-063R | 0 | 0 | 1 |
| Front Panel Switch | 1032510, 1032496 | 1 | 1 | 2 |
| Line Filter | 100-242-1199R (100-242-1293R for 4 KW units and 15 kHz 3.3 KW & 100-242- 1265R for 30 kHz 1.5 KW 120VAC only) | 0 | 0 | 1 |
| Line Fuse (s), 20a | 200-049-015R | 2 | 4 | 6 |
| DC Fan | 100-126-015R | 2 | 2 | 4 |
| Fan Filter Kit | 101-063-614 | * | * | * |
| I/O Board | 100-242-1197R | 0 | 1 | 2 |
| Line Cord | 100-246-1371 (100-246-1727 for 4 KW units, 15 kHz, 30 kHz 1.5 KW 120VAC only) | 0 | 1 | 2 |
| Membrane Panel | 100-242-926R | 0 | 0 | 1 |
| DC Power Supply | 200-132-294R | | | |
| RF Harness | 100-246-949R | 0 | 0 | 1 |

* Quantity varies depending on amount of airborne particulate in your environment.

7.3.4 Circuits

Figure 7.1 Interconnect Diagram, Power Supply

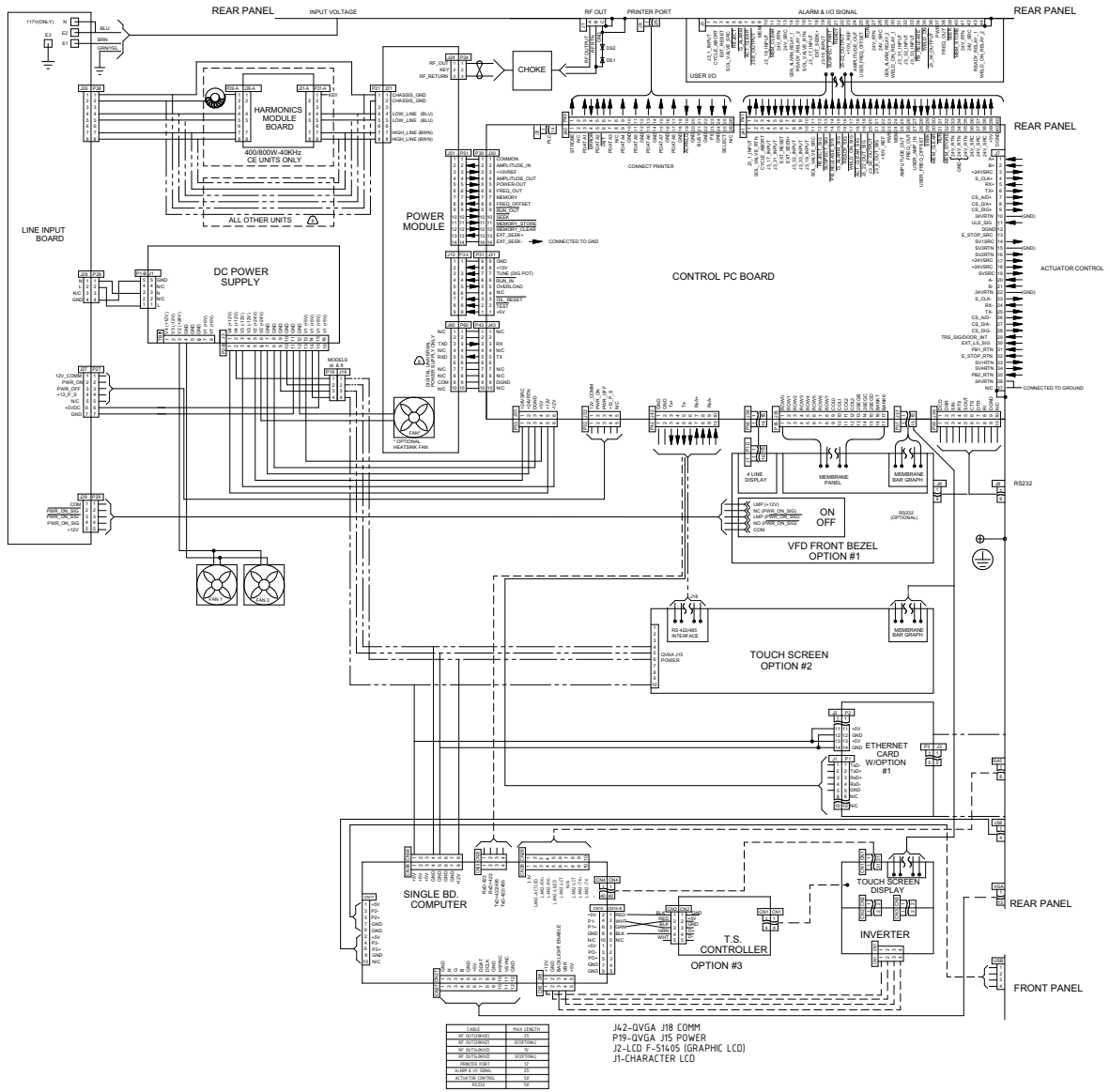



7.4 Troubleshooting

When the 2000X Power Supply encounters a situation that is outside of the normal conditions, an alarm is generated. If there is any alarm condition, the Front Panel displays the number of alarms and generates an audible alarm. Pressing the Alarm button will display a message for corrective action. Some types of alarms have a secondary button to press to address the alarm. If no additional information is displayed, refer to the System Alarm Tables.

If you use the Emergency Stop button on the Actuator to terminate a weld, twist the button to reset it. (The welder will not operate until this button is reset.) You must then press Reset at the power supply. If you are running automation, you can use external reset that is connected to your User I/O board.

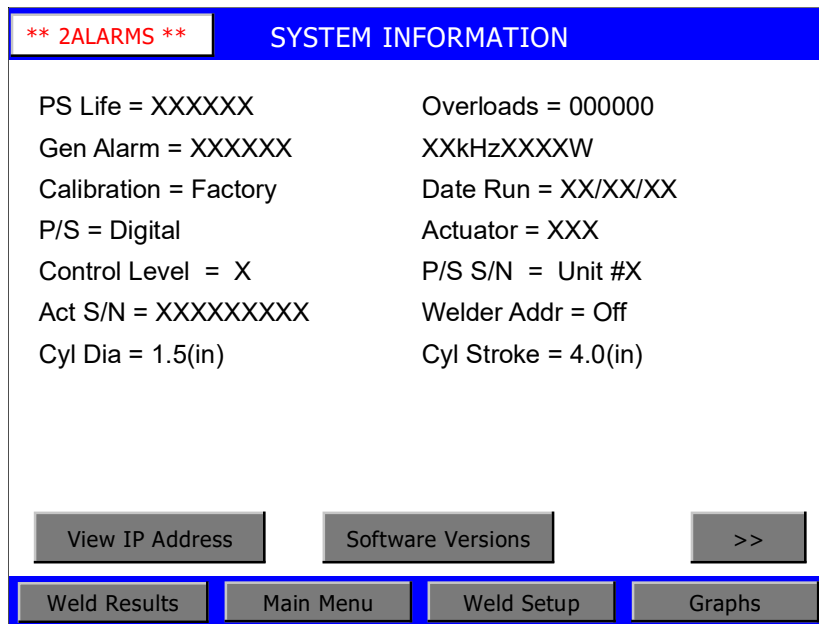
Figure 7.2 Alarm Signal Displayed on the System Information Screen



| NOTICE | |
|---|---|
|  | <p>If you have been directed to this Section from an alarm message on the Power Supply screen, go directly to the table for the alarm type specified in the message. Location of the alarm tables is detailed in the following text. If your alarm pop up is from the Print menu, run another cycle and try to re-print your graph. These tables do not include Printer alarms.</p> |

| NOTICE | |
|---|--|
|  | <p>If you experience an Operating System error message, please turn the power supply off (Wait 30 Seconds), and then turn the power supply on again, this will initiate a restart sequence for the Operating System. If the Operating System error persists, please contact Branson Product Support by calling the appropriate department as indicated in Table 1.1 Branson Contacts, on Section 1.5.3 Departments to Contact.</p> |

This section details the alarm conditions that you can encounter while using the 2000X Power Supply. There are eight classes of alarms: Cycle Modified, Failure of, No Cycle, Setup, Suspect, Reject, Overload, and Note. Following is a brief description of each type of alarm, followed by [Table 7.4](#) through [Table 7.10](#) which detail alarm messages, causes, and corrective actions for each type of alarm.

- A Cycle Modified alarm ([Table 7.4](#)) occurs when the most recent weld cycle has been modified by some event. For example, if the amplitude step did not occur as requested. The specific alarm that has occurred is indicated by the message on your display or your printer, and will advance the general alarm counter. If you encounter numerous or successive cycle modified alarms, review your weld parameter setup. See individual alarms for advancement of cycle counter.
- A Failure of alarms, Equipment Failure, ([Table 7.5](#)) are those which might occur for hardware failure, or hardware disconnected. For example, if the door were open to replace a stack, a Door/Trigger Switch alarm would occur. The specific equipment failure that has occurred is indicated by the message on your display or your printer. Repair or replace the equipment before you run another weld cycle. Failure Of: alarms will advance the general alarm counter. For more detailed information on repairing your equipment contact Branson Product Support by calling the appropriate department as indicated in [Table 1.1 Branson Contacts](#), on Section [1.5.3 Departments to Contact](#).

| WARNING | |
|--|---|
|  | <p>You should always power down your system prior to repairing any portion of it.</p> |

- A No Cycle alarm ([Table 7.6](#)) occurs when the most recent weld cycle was aborted before any weld took place. The specific no weld failure that has occurred is indicated by the message on your display or your printer. No Cycle alarms will advance the general alarm counter, but will not advance the cycle counter. You should continue with the next weld cycle; in most cases the part can be re-used.
- A Suspect or Reject alarm ([Table 7.7](#)) occurs when the most recent weld cycle fell outside your programmed limits. The specific conflict that has occurred is indicated by the message on your display or your printer. Suspect/Reject alarms will advance the general alarm counter, but only once per cycle regardless of the number of alarms generated. You should inspect any part that was welded during a cycle that resulted in an alarm. If you encounter numerous or successive alarms you should review your weld parameter setup.
- A Setup alarm ([Table 7.8](#)) occurs when you have entered parameters that create a conflict with other parameters. For example, trying to step an amplitude at weld time 1.000 seconds, but the weld time is only set for 0.500 seconds. The specific conflict that has occurred is indicated by the message on your display or your printer. All setup alarms must be resolved before a new cycle can be run. Setup alarms will advance the general alarm counter, but will not advance the cycle counter. If you are uncertain as to the cause of the conflict, it might be helpful to print out your current setup so that you can see your entire setup, resolve the conflict, and proceed.
- An Overload alarm ([Table 7.9](#)) occurs when your ultrasonic power supply has overloaded. Overload alarms advance the general alarms counter. The specific overload that has occurred is indicated by the message on your display or your printer.
- Note alarms ([Table 7.10](#)) occur to alert you that an alarm is imminent or the cycle ran with authorized modifications.

7.5 System Alarm Tables

The following tables detail alarms that you can encounter on the 2000X Power Supply, listed alphabetically by the Display Message that is presented on the front panel. The message on the display panel of the Power Supply is shown in the first column. A more detailed message that you can print is shown in the second column.

The third and fourth columns indicate the condition that led to the alarm and the corrective action you should take.

7.5.1 Alarm Index

An alphabetical list of the alarms that appear on the system display and on printouts is included in [Appendix B: Alarm Index](#). All alarm page numbers are hyper-linked to the full description, which describes the cause of the alarm condition and the steps to resolve it.

7.5.2 Cycle Modified Alarms

Table 7.4 Cycle Modified Alarms and Messages, with Probable Cause and Corrective Action

| Display Message | Printer Message | Alarm Condition/ Cause | Corrective Action |
|--|--------------------------|--|---|
| ABS Cutoff | Absolute Distance Cutoff | The absolute distance cutoff you set was reached. The main parameter you set for the weld cycle was not used to the end of the cycle. | Manually inspect the part. If the part is acceptable, you might want to adjust your main parameter to avoid this alarm. |
| Ground Detect Abort | Ground Detect Abort | The cycle was aborted because ground detect occurred during Weld or Hold | Manually inspect the part. If the part is acceptable, you might want to adjust your main parameter to avoid this alarm. |
| Ground Detect Abort (Message also appears in "No Cycle Alarms and Messages.") | Ground Detect Abort | The cycle was aborted because ground detect occurred during weld or hold. | Verify part placement and distance parameters. |
| Max Timeout | Max Timeout | The ultrasonics ran for the maximum allowed time because the set parameter could not be achieved. | Manually inspect the part. If the part is acceptable, you might want to adjust your main parameter to avoid this alarm. |

Table 7.4 Cycle Modified Alarms and Messages, with Probable Cause and Corrective Action

| Display Message | Printer Message | Alarm Condition/ Cause | Corrective Action |
|-------------------|--|---|---|
| No Amplitude Step | Time Value for Amplitude Step not Reached | The amplitude time step trigger was not reached. | Manually inspect the part. If the part is acceptable, turn amplitude stepping off. If the part is not acceptable, you might want to adjust your main parameter. |
| No Amplitude Step | External signal for Amplitude Step did not occur | The amplitude step at external signal input was not received. | Make sure Ext Signal is defined in the User I/O. |
| No Amplitude Step | Power level for Amplitude Step not Reached | The amplitude power step level was not reached. | Manually inspect the part. If the part is acceptable, turn amplitude stepping off. If the part is not acceptable, you might want to adjust your main parameter. |
| No Amplitude Step | Energy Value for Amplitude Step not Reached | The amplitude energy step trigger was not reached. | Manually inspect the part. If the part is acceptable, turn amplitude stepping off. If the part is not acceptable, you might want to adjust your main parameter. |
| No Amplitude Step | Collapse Distance for Amplitude Step not Reached | The amplitude collapse distance step trigger was not reached. | Manually inspect the part. If the part is acceptable, turn amplitude stepping off. If the part is not acceptable, you might want to adjust your main parameter. |
| Sonics Disabled | Ultrasonics Disabled by user input | | Remove Sonics Disable input. |

Table 7.4 Cycle Modified Alarms and Messages, with Probable Cause and Corrective Action

| Display Message | Printer Message | Alarm Condition/ Cause | Corrective Action |
|----------------------|---|--|---|
| Peak Power Cutoff | Peak Power Cutoff | The peak power cutoff was reached. The main parameter you set for the weld cycle was not used. | Manually inspect the part. If the part is acceptable, you might want to adjust your main parameter to avoid this alarm. |
| Trigger Lost in Hold | Trigger Lost during Hold | The cycle was aborted because trigger force on the part was lost. | Verify that there is adequate pressure from your pneumatic supply. |
| Trigger > End Force | Trigger Force is greater than the End Force | The force at the end of the weld is less than the trigger force you set. | Increase your downspeed and/or system pressure. If you very frequently receive this alarm, contact Branson |
| Trigger Lost in Weld | Trigger Lost during Weld | The cycle was aborted because trigger force on the part was lost. | Verify that there is adequate pressure from your pneumatic supply. Verify stroke length < 3.75" |

7.5.3 Failure of, Alarms

Table 7.5 Failure of Alarms and Messages, with Probable Cause and Corrective Action

| Display Message | Printer Message | Alarm Condition/ Cause | Corrective Action |
|-------------------------|---------------------------------|---|---|
| Actuator Clear Function | Actuator Clear Function Failure | The carriage is home before the Actuator clear condition was met. | Make sure the linear encoder cable is connected properly. Replace Linear Encoder. Repair/replace Control Board. |

Table 7.5 Failure of Alarms and Messages, with Probable Cause and Corrective Action

| Display Message | Printer Message | Alarm Condition/ Cause | Corrective Action |
|------------------------------------|---|---|---|
| Actuator Type | The Actuator Type was changed since the last weld cycle | Actuator type detected at power up is different from the actuator type that was used on the last weld cycle. Checked at power up and after E-Stop is removed. | Verify serial number (excepting ae/ao) and type, then reset. If you did not change the actuator, troubleshoot your system. |
| Actuator NovRam Error Code = 10 | Actuator NovRam failed | The Actuator NovRam has corrupted data | Perform a Cold Start. Check setup/cable. Repair/replace Interface board in actuator. |
| Actuator NovRam Error Code = 20 | Actuator NovRam failed | Cylinder size is not 1.5, 2.0, 2.5, 3.0, 50mm, 63mm, 80mm, or Custom. | Perform a Cold Start. Check setup/cable. Repair/replace Interface board in actuator. |
| Actuator NovRam Error Code = 30 | Actuator NovRam failed | Stroke length is not 4", 5", 6", 7", 8", 80mm, 160mm, or Custom. | Perform a Cold Start. Check setup/cable. Repair/replace Interface board in actuator. |
| Actuator NovRam Error Code = 40 | Actuator NovRam failed | When each successive element in the Pressure Sensor Calibration Table is not greater than the preceding one. | Perform a Cold Start. Check setup/cable. Repair/replace Interface board in actuator. |
| Actuator NovRam Error Code = 50 | Actuator NovRam failed | When each successive element in the Load Cell Table is not larger than the preceding one. | Perform a Cold Start. Check setup/cable. Repair/replace Interface board in actuator. |
| Actuator NovRam Error Code = 60 | Actuator NovRam failed | Could not write to the actuator NovRam. | Perform a Cold Start. Check setup/cable. Repair/replace Interface board in actuator. |

Table 7.5 Failure of Alarms and Messages, with Probable Cause and Corrective Action

| Display Message | Printer Message | Alarm Condition/ Cause | Corrective Action |
|---------------------|--|--|---|
| Door/Trigger Switch | Door/Trigger Switch Failure | The actuator door (front cover) is ajar or missing, or the Trigger Switch was not engaged. | Secure the Actuator door or verify the Trigger Switch electrical connections and continuity. |
| Ethernet Link Lost | Ethernet Link Lost | The Ethernet link has been lost. Data collection through the link is now stopped. | Because data collection was defined by the user, the welder will stop cycling until the link is restored or data collection is turned off. VGA only. |
| External Switch | External Switch | The external input is either improperly configured, in the wrong condition, or failed. | Reconfigure properly, replace, or set proper condition. |
| Horn Return Timeout | Horn Return Timeout | The Horn did not retract to the home position after the weld was completed and within the correct time. The Horn might be jammed or air pressure might have failed. The Upper Limit Switch might also have failed. | Verify that air pressure is correct. Check for obstructions or jams that would prevent the Horn from returning. Verify the operation of the Upper Limit Switch. |
| P/S NovRam | Power Supply NovRam Failed | The power supply NovRam failed. It is checked only at power up. | Repair/replace Control Board. |
| Preset Data/BBR | Failure of Preset Data or Battery Backed RAM | Corrupted data in preset. Checked at power up. | Replace BBR or repair/replace the Control Board. Replace battery. |

Table 7.5 Failure of Alarms and Messages, with Probable Cause and Corrective Action

| Display Message | Printer Message | Alarm Condition/ Cause | Corrective Action |
|--|-------------------------------|--|---|
| Pretrigger Timeout | Pretrigger Timeout | Pretrigger has not occurred within 10 seconds of carriage leaving home (of upper limit becoming inactive). | Check the distance setting for pretrigger to be sure the carriage is traveling at least that far. Repair/replace Control Board. |
| Printer Buffer Full | [No message sent to printer.] | Your printer buffer is full and no more data can be sent to your printer. | Verify that the printer is online and operational and wait until some data has been printed. |
| Printer Offline | [No message sent to printer.] | Your printer is offline or not connected. | Verify that the printer is online and operational and that connections are maintained. |
| Recalibrate Actuator Error Code = 100 | Recalibrate Actuator | Either the Actuator serial number is different from the last time power was turned on, or your new setup requires a calibration. | Run an Actuator Calibration procedure from the Alarm Information screen or from Calibrate in the Main Menu. |
| Recalibrate Actuator Error Code = 200 | Recalibrate Actuator | A collapse of more than 0.2500" and less than 35 lbs. of force was reached. | Run an Actuator Calibration procedure from the Alarm Information screen or from Calibrate in the Main Menu. Also check part alignment. |
| Recalibrate Actuator Error Code = 300 | Recalibrate Actuator | A change in horn weight of 6-7 lbs since the last power down or E-stop. | Run an Actuator Calibration procedure from the Alarm Information screen or from Calibrate in the Main Menu. |

Table 7.5 Failure of Alarms and Messages, with Probable Cause and Corrective Action

| Display Message | Printer Message | Alarm Condition/ Cause | Corrective Action |
|---|----------------------|--|--|
| Recalibrate Actuator Error Code = 400 | Recalibrate Actuator | Carriage travel greater than -0.25 after trigger. | Run an Actuator Calibration procedure from the Alarm Information screen or from Calibrate in the Main Menu. |
| Recalibrate Actuator Error Code = 600 | Recalibrate Actuator | Actuator type has changed | Run an Actuator Calibration procedure from the Alarm Information screen or from Calibrate in the Main Menu. |
| Recalibrate Actuator Error Code = 700 | Recalibrate Actuator | In Horn Down, a bad Trigger has occurred. | Run an Actuator Calibration procedure from the Alarm Information screen or from Calibrate in the Main Menu. |
| Recalibrate Actuator Error Code = 800 | Recalibrate Actuator | Part contact flag has been lost. | Run an Actuator Calibration procedure from the Alarm Information screen or from Calibrate in the Main Menu. |
| Recalibrate Actuator Error Code = 900 | Recalibrate Actuator | Carriage travels greater than 0.250 and less than 35 lbs. force was developed after part contact and before trigger. | Run an Actuator Calibration procedure from the Alarm Information screen or from Calibrate in the Main Menu. |
| Recalibrate Actuator Error Code = 1000 | Recalibrate Actuator | Upgrade from version 6.00 aed to version 8.0 has been detected. | Run an Actuator Calibration procedure from the Alarm Information screen or from Calibrate in the Main Menu, using maximum stroke length. |

Table 7.5 Failure of Alarms and Messages, with Probable Cause and Corrective Action

| Display Message | Printer Message | Alarm Condition/ Cause | Corrective Action |
|---|----------------------------------|---|--|
| Recalibrate Actuator Error Code = 1100 | Recalibrate Actuator | Upgrade from version 8.06 to 8.04 or 8.05 has been detected. | Run an Actuator Calibration procedure from the Alarm Information screen or from Calibrate in the Main Menu. |
| Recalibrate Actuator Error Code = 1200 | Recalibrate Actuator | A Reset Act. Cal has been done. The restored value is from an 8.04 or 8.05 calibration. | Run an Actuator Calibration procedure from the Alarm Information screen or from Calibrate in the Main Menu. |
| Start Sw Time | Start Switch Stagger Time Missed | You did not activate both start switches within the required time interval. | Activate both start switches at the same time to rerun the cycle. |
| Start Switch Closed | Start Switch Closed Failure | The start switch(es) are still active two seconds after the carriage is home (ULS is active). | For manual operation: Release the Start Switches when the beep sounds. For automated operation: The PLC (Programmable Logic Controller) should release the start signal when the Weld On signal or Start Switch release signal is active. |
| Start Switches Lost | Start Switches Lost | Checked after both start switches, and before trigger. There is a 10 ms debounce time before considered lost. | Press start switches again. |

Table 7.5 Failure of Alarms and Messages, with Probable Cause and Corrective Action

| Display Message | Printer Message | Alarm Condition/ Cause | Corrective Action |
|--------------------|--|--|---|
| Thermal Overload | Thermal Overload | Thermal sensors on the Power Supply indicate that the temperature is above the maximum operating temperature. | Lower the duty cycle by decreasing the on time or increasing the off time. Ensure fans are operational and internal components are free of dust. |
| Trigger Switch | Trigger Switch | Trigger Switch Failed. Checked during ready, during test ready and during power up. | The Recal Actuator line and submenu will only appear on AED actuators. Doing a calibration will reset this alarm. |
| Ultrasonics P/S | Ultrasonics Power Supply Not Present or Failed | Checked during power up. Seek was requested but no run signal detected, or the amplitude from the Power output is less than 2%. A DUPS communication error occurred. | Contact Branson. Repair/replace the Power Supply Module. |
| Upper Limit Switch | Upper Limit Switch Failed | Upper Limit Switch was not engaged at the end of weld cycle. The switch might have failed or the electrical wiring might be loose. | Verify the electrical connections for the Upper Limit Switch or replace the switch. |
| USB Memory Full | USB Memory Full | Data was selected to be saved on the USB memory stick, but the memory stick is now full. | Welding will be stopped until corrected. If all data from the weld will not fit, then no data will be written. All data from any given weld cycle must be written on one USB stick. |

Table 7.5 Failure of Alarms and Messages, with Probable Cause and Corrective Action

| Display Message | Printer Message | Alarm Condition/ Cause | Corrective Action |
|-----------------|--|---|---|
| USB Memory Lost | USB Memory Failure | The USB memory stick has been removed or it is not functional. | Since weld data was configured to be saved on the USB stick, welding must be stopped until either the USB stick is functional or weld data is no longer required to be saved. |
| Wrong Actuator | Wrong Actuator ae/aed cannot be used with this level control | The Power Supply has detected an Actuator that cannot be used with a Power Supply of this type. | Use the correct Actuator for this Power Supply. |

7.5.4 No Cycle Alarms

Table 7.6 No Cycle Alarms and Messages, with Probable Cause and Corrective Action

| Display Message | Printer Message | Alarm Condition/ Cause | Corrective Action |
|---------------------|----------------------------------|--|--|
| Abs Before Trg | Absolute Distance Before Trigger | The absolute distance has been reached before trigger. This alarm in other modes means the absolute cutoff distance has been reached before trigger. | Reset your absolute distance parameter through the Alarm Information screen or the Setup menu. |
| Amp Step Before Trg | Amp Step Before Trigger | The amplitude step trigger has been detected within 2 ms of start of weld time. | Reset your amplitude step parameter through the Alarm Information screen or the Setup menu. |
| Trg Delay Timeout | External Trigger Delay Timeout | Ext trigger delay has been turned on, but the assigned input did not go inactive within the 30 seconds allowed. | Check external timing. Activate Ext Trg Delay. |

Table 7.6 No Cycle Alarms and Messages, with Probable Cause and Corrective Action

| Display Message | Printer Message | Alarm Condition/ Cause | Corrective Action |
|---|---------------------------|---|--|
| Ground Detect | Ground Detect Cutoff | The ground detect input is either improperly configured, in the wrong condition or failed. | Reconfigure properly, change condition or replace faulty input. |
| Ground Detect Abort (This message also appears in the Cycle Modified Alarms and Messages.) | Ground Detect Abort | The cycle was aborted because ground detect occurred before trigger. | Verify part placement and distance parameters. |
| Missing Part Abort | Missing Part Abort | Checked during downstroke. The missing part minimum distance has not been reached before trigger occurred or the maximum distance has been exceeded before trigger occurred. | Insert a part into the fixture. Use the horn down feature to determine the distance to the part, and reset the minimum and maximum settings as necessary through the Alarm Information screen or Setup menu. |
| Trig Before Pretrig | Trigger Before Pretrigger | The cycle was aborted because the trigger force was reached before the pretrigger distance. | Reset your pretrigger distance in the setup menu. |
| Trig Before Pretrig | Trigger before Pretrigger | Trigger has occurred before pre-trigger distance, upper limit switch is inactive, or pre-trigger time delay has not timed out. | Check each condition and correct where necessary. |
| Trigger Timeout | Trigger Timeout | Trigger force was not achieved within the 10 second allowed time. | Verify that the part is in the fixture; verify that there is adequate pressure from your pneumatic supply. Verify stroke length <3.75" |

7.5.5 Suspect or Reject Alarms

Table 7.7 Suspect/Reject Alarms and Messages, with Probable Cause and Corrective Action

| Display Message | Printer Message | Alarm Condition/ Cause | Corrective Action |
|--------------------|------------------------------------|--|--|
| + R Col Dist Limit | + Reject Collapse Distance Limit. | The collapse distance used in the most recent weld was greater than the upper reject limit you set. | Discard the part. If you encounter numerous or successive alarms with good parts, you might change your reject collapse distance limits. |
| + S Col Dist Limit | + Suspect Collapse Distance Limit. | The collapse distance used in the most recent weld was greater than the upper suspect limit you set. | Manually inspect the part for a good weld. If you encounter numerous or successive alarms with good parts, you might change your suspect collapse distance limits. |
| + S Trg Dist Limit | + Suspect Trigger Distance Limit | The trigger distance used in the most recent weld was greater than the upper suspect limit you set. | Manually inspect the part for a good weld. If you encounter numerous or successive alarms with good parts, you might change your suspect trigger distance limits. |
| + R Abs Dist Limit | + Reject Absolute Distance Limit | The actual distance value exceeded the plus reject absolute distance limit. | Discard the part if you encounter numerous or successive alarms with good parts. Consider changing your Absolute settings. |
| + R Energy Limit | + Reject Energy Limit | The actual energy value exceeded the plus reject energy limit. | Discard the part if you encounter numerous or successive alarms with good parts. Consider changing your Energy settings. |

Table 7.7 Suspect/Reject Alarms and Messages, with Probable Cause and Corrective Action

| Display Message | Printer Message | Alarm Condition/ Cause | Corrective Action |
|----------------------|---------------------------------|--|---|
| + R Weld Force Limit | + Reject Weld Force Limit | The actual Weld Force exceeded the plus Reject Weld Force limit. | Discard the part if you encounter numerous or successive alarms with good parts. Consider changing your Weld Force settings. |
| + R Pk Power Limit | + Reject Peak Power Limit | The actual peak power value exceeded the plus reject peak power limit. | Discard the part if you encounter numerous or successive alarms with good parts. Consider changing your Peak Power settings. |
| + R Time Limit | + Reject Time Limit | The actual time value exceeded the plus reject time limit. | Discard the part if you encounter numerous or successive alarms with good parts. Consider changing your Time settings or your reject time limits. |
| + R Trg Dist Limit | + Reject Trigger Distance Limit | The actual trigger distance value exceeded the plus reject trigger distance limit. | Adjust + reject trigger distance limit through the Alarm Information screen or Setup menu. Discard the part if you encounter numerous or successive alarms. |
| + R Weld Force Limit | + Reject Weld Force Limit | Actual Weld Force did not reach minus reject Weld Force limit. | Adjust +reject weld force through the Alarm Information screen or Setup menu. Discard the part if you encounter numerous or successive alarms. |

Table 7.7 Suspect/Reject Alarms and Messages, with Probable Cause and Corrective Action

| Display Message | Printer Message | Alarm Condition/ Cause | Corrective Action |
|----------------------|-----------------------------------|--|---|
| + S Abs Dist Limit | + Suspect Absolute Distance Limit | The actual absolute distance value did not reach the plus suspect absolute distance limit. | Inspect your parts. For numerous or successive alarms, you might adjust +suspect trigger distance limit through the Alarm Information screen or Setup menu. |
| + S Col Dist Limit | + Suspect Collapse Distance Limit | The actual collapse distance value exceeded the plus suspect collapse distance limit. | Inspect your parts. For numerous or successive alarms, you might adjust the collapse distance value through the Alarm Information screen or Setup menu. |
| + S Energy Limit | + Suspect Energy Limit | The actual energy value exceeded the plus suspect energy limit. | Inspect your parts. For numerous or successive alarms, you might adjust the Energy value through the Alarm Information screen or Setup menu. |
| + S Weld Force Limit | + Suspect Weld Force Limit | The actual Weld Force exceeded the plus suspect Weld Force limit. | Inspect your parts. For numerous or successive alarms, you might adjust the Weld Force value through the Alarm Information screen or Setup menu. |
| + S Pk Power Limit | + Suspect Peak Power Limit | The actual peak power value exceeded the plus suspect peak power limit. | Inspect your parts. For numerous or successive alarms, you might adjust the Peak Power value through the Alarm Information screen or Setup menu. |

Table 7.7 Suspect/Reject Alarms and Messages, with Probable Cause and Corrective Action

| Display Message | Printer Message | Alarm Condition/ Cause | Corrective Action |
|--------------------|-----------------------------------|--|--|
| + S Time Limit | + Suspect Time Limit | The actual time value exceeded the plus suspect time limit. | Inspect your parts. For numerous or successive alarms, you might adjust the Time value through the Alarm Information screen or Setup menu or change suspect time limits. |
| + S Trg Dist Limit | + Suspect Trigger Distance Limit | The actual trigger distance value exceeded the plus suspect trigger distance limit. | Inspect your parts. For numerous or successive alarms, you might adjust the Trigger Distance Limit through the Alarm Information screen or Setup menu. |
| + R Abs Dist Limit | + Reject Absolute Distance Limit | The absolute distance used in the most recent weld was greater than the upper reject limit you set. | Discard the part. If you encounter numerous or successive alarms with good parts, you might change your reject absolute distance limit. |
| + R Abs Dist Limit | + Reject Absolute Distance Limit | The absolute distance used in the most recent weld was greater than the upper reject limit you set. | Discard the part. If you encounter numerous or successive alarms with good parts, you might change your reject absolute distance limit. |
| + S Abs Dist Limit | + Suspect Absolute Distance Limit | The absolute distance used in the most recent weld was greater than the upper suspect limit you set. | Manually inspect the part for a good weld. If you encounter numerous or successive alarms with good parts, you might change your suspect absolute distance limits. |

Table 7.7 Suspect/Reject Alarms and Messages, with Probable Cause and Corrective Action

| Display Message | Printer Message | Alarm Condition/ Cause | Corrective Action |
|--------------------|-----------------------------------|---|--|
| - R Abs Dist Limit | - Reject Absolute Distance Limit | The absolute distance used in the most recent weld was less than the lower reject limit you set. | Discard the part. If you encounter numerous or successive alarms with good parts, you might change your reject absolute distance limit. |
| - S Abs Dist Limit | - Suspect Absolute Distance Limit | The absolute distance used in the most recent weld was less than the lower suspect limit you set. | Manually inspect the part for a good weld. If you encounter numerous or successive alarms with good parts, you might change your suspect absolute distance limits. |
| + R Energy Limit | + Reject Energy Limit | The energy used in the most recent weld was greater than the upper reject limit you set. | Discard the part. If you encounter numerous or successive alarms with good parts, you might change your reject energy limits. |
| + S Energy Limit | + Suspect Energy Limit | The energy used in the most recent weld was greater than the upper suspect limit you set. | Manually inspect the part for a good weld. If you encounter numerous or successive alarms with good parts, you might change your suspect energy limits. |
| Energy Not Reached | Energy Not Reached | The weld time has been extended up to 50% and the minimum energy has still not been reached. | Discard the part. If you encounter numerous or successive alarms with good parts, you might change your minimum energy setting. |

Table 7.7 Suspect/Reject Alarms and Messages, with Probable Cause and Corrective Action

| Display Message | Printer Message | Alarm Condition/ Cause | Corrective Action |
|--------------------|----------------------------|---|---|
| - R Energy Limit | - Reject Energy Limit | The energy used in the most recent weld was less than the lower reject limit you set. | Discard the part. If you encounter numerous or successive alarms with good parts, you might change your reject energy limits. |
| - S Energy Limit | - Suspect Energy Limit | The energy used in the most recent weld was less than the lower suspect limit you set. | Manually inspect the part for a good weld. If you encounter numerous or successive alarms with good parts, you might change your suspect energy limits. |
| + R Pk Power Limit | + Reject Peak Power Limit | The peak power used in the most recent weld was greater than the upper reject limit you set. | Discard the part. If you encounter numerous or successive alarms with good parts, you might change your reject peak power limits. |
| + S Pk Power Limit | + Suspect Peak Power Limit | The peak power used in the most recent weld was greater than the upper suspect limit you set. | Manually inspect the part for a good weld. If you encounter numerous or successive alarms with good parts, you might change your suspect peak power limits. |
| - R Pk Power Limit | - Reject Peak Power Limit | The peak power used in the most recent weld was less than the lower reject limit you set. | Discard the part. If you encounter numerous or successive alarms with good parts, you might change your reject peak power limits. |

Table 7.7 Suspect/Reject Alarms and Messages, with Probable Cause and Corrective Action

| Display Message | Printer Message | Alarm Condition/ Cause | Corrective Action |
|--------------------|----------------------------------|--|---|
| - S Pk Power Limit | - Suspect Peak Power Limit | The peak power used in the most recent weld was less than the lower suspect limit you set. | Manually inspect the part for a good weld. If you encounter numerous or successive alarms with good parts, you might change your suspect peak power limits. |
| - R Abs Dist Limit | - Reject Absolute Distance Limit | The actual distance value did not reach the minus reject absolute distance limit. | Discard the part if you encounter numerous or successive alarms with good parts. Consider changing your Absolute settings. |
| - R Col Dist Limit | - Reject Collapse Distance Limit | The collapse distance used in the most recent weld was less than the lower reject limit you set. | Discard the part. If you encounter numerous or successive alarms with good parts, you might change your reject collapse distance limits. |
| - R Freq Limit | - R Freq Limit | The system Bandwidth Limit (SBL) function has determined the frequency has dropped too much and is now close to the series resonant point. | Verify integrity of stack. Review application. |
| +R Freq Limit | +R Freq Limit | The system Bandwidth Limit (SBL) function has determined the frequency has risen too much and is now close to the series resonant point. | Verify integrity of stack. Review application. |

Table 7.7 Suspect/Reject Alarms and Messages, with Probable Cause and Corrective Action

| Display Message | Printer Message | Alarm Condition/ Cause | Corrective Action |
|----------------------|---------------------------------|--|---|
| -R PMC Band Limit | -R PMC Band Limit | The Power Match Curve function has detected points below the acceptable curve. | Run additional cycles to determine if this is a trend or an anomaly. Examine process and adjust accordingly. |
| +R PMC Band Limit | +R PMC Band Limit | The Power Match Curve function has detected points above the acceptable curve. | Run additional cycles to determine if this is a trend or an anomaly. Examine process and adjust accordingly. |
| - R Weld Force Limit | - Reject Weld Force Limit | The actual Weld Force did not reach the minus reject Weld Force limit. | Adjust - reject weld force through the Alarm Information screen or Setup menu. Discard the part if you encounter numerous or successive alarms. |
| - R Time Limit | - Reject Time Limit | The actual time value did not reach the minus reject time limit. | Discard the part if you encounter numerous or successive alarms with good parts. Consider changing your Time settings. |
| - R Trg Dist Limit | - Reject Trigger Distance Limit | The actual trigger distance value did not reach the minus reject trigger distance limit. | Adjust - reject trigger distance limit through the Alarm Information screen or Setup menu. Discard the part if you encounter numerous or successive alarms. |

Table 7.7 Suspect/Reject Alarms and Messages, with Probable Cause and Corrective Action

| Display Message | Printer Message | Alarm Condition/ Cause | Corrective Action |
|----------------------|----------------------------------|---|---|
| - S Col Dist Limit | - Suspect Collapse Dist Limit | The actual collapse distance value did not reach the minus suspect collapse distance limit. | Inspect your parts. For numerous or successive alarms, you might adjust the collapse distance value through the Alarm Information screen or Setup menu. |
| - S Weld Force Limit | - Suspect Weld Force Limit | The actual Weld Force did not reach the minus suspect Weld Force limit. | Inspect your parts. For numerous or successive alarms, you might adjust the Weld Force value through the Alarm Information screen or Setup menu. |
| - S Time Limit | - Suspect Time Limit | The time used in the most recent weld was less than the lower suspect limit you set. | Inspect your parts. For numerous or successive alarms, you might adjust the Time value through the Alarm Information screen or Setup menu. |
| - S Trg Dist Limit | - Suspect Trigger Distance Limit | The actual trigger distance value did not reach the minus suspect trigger distance limit. | Inspect your parts. For numerous or successive alarms, you might adjust the Trigger Distance Limit through the Alarm Information screen or Setup menu. |

7.5.6 Setup Alarms

Table 7.8 Setup Alarms and Messages, with Probable Cause and Corrective Action

| Display Message | Alarm Condition/Cause | Corrective Action |
|-------------------|---|--|
| Amp Step Conflict | The distance you have set for the amplitude to step is equal to or greater than the absolute distance you have set. | Change the step distance for the amplitude and/or the absolute distance settings. |
| Amp Step Conflict | The energy level you have set for the amplitude to step is in conflict with the energy level you have set for the weld cycle. | Change the step energy for the amplitude and/or the energy level for the weld cycle. |
| Amp Step Conflict | The time that you have set for the amplitude to step is greater than the time that you have set for the weld cycle. | Change the step time for the amplitude and/or the time setting for the weld cycle. |
| Amp Step Conflict | The amplitude step value is equal to or greater than the plus reject peak power limit value. | Change the amplitude step or +reject peak power limit through the Alarm Information screen or Setup menu. |
| Amp Step Conflict | The amplitude step value is equal to or greater than the plus suspect peak power limit. | Change the amplitude step or +suspect peak power limit through the Alarm Information screen or Setup menu. |
| Amp Step Conflict | The amplitude step value is equal to or greater than the plus reject energy limit. | Change the amplitude step or +reject energy limit through the Alarm Information screen or Setup menu. |
| Amp Step Conflict | The amplitude step value is equal to or greater than the plus suspect energy limit. | Change the amplitude step or +suspect energy limit through the Alarm Information screen or Setup menu. |
| Amp Step Conflict | The amplitude step at power value is equal to or greater than the peak power value. This alarm is for peak power mode only. | Change the amplitude step or peak power main parameter through the Alarm Information screen or Setup menu. |
| Amp Step Conflict | The amplitude step at energy value is equal to or greater than the max energy compensation value. | Change the amplitude step or maximum energy compensation limit through the Alarm Information screen or Setup menu. |

Table 7.8 Setup Alarms and Messages, with Probable Cause and Corrective Action

| Display Message | Alarm Condition/Cause | Corrective Action |
|----------------------|--|--|
| Amp Step Conflict | The amplitude step value is equal to or greater than the peak power cutoff value. This alarm is in all modes but peak power. | Change the amplitude step or peak power cutoff through the Alarm Information screen or Setup menu. |
| Amp Step Conflict | The amplitude step at time value is equal to or greater than the maximum timeout value. This occurs in all modes except time. | Change the amplitude step at time value and/or the maximum timeout value through the Alarm Information screen or Setup menu. |
| Cutoff Conflict | The minus reject power limit is equal to or greater than the peak power cutoff value. | Change the - reject power limit or peak power cutoff through the Alarm Information screen or Setup menu. |
| Cutoff Conflict | The plus reject power limit is equal to or greater than the peak power cutoff value. | Change the +reject power limit or peak power cutoff through the Alarm Information screen or Setup menu. |
| Cutoff Conflict | The minus suspect power limit is equal to or greater than the peak power cutoff value. | Change the - suspect power limit or peak power cutoff through the Alarm Information screen or Setup menu. |
| Cutoff Conflict | The plus suspect power limit is equal to or less than the peak power cutoff value. | Change the +suspect power limit or peak power cutoff through the Alarm Information screen or Setup menu. |
| Energy Comp Conflict | The plus reject energy limit is equal to or less than the minimum energy compensation value. This alarm occurs in time mode only. | Change the +Reject energy limit or minimum energy compensation through the Alarm Information screen or Setup menu. |
| Energy Comp Conflict | The plus suspect energy limit is equal to or less than the minimum energy compensation value. This alarm occurs in time mode only. | Change the +Suspect energy limit or minimum energy compensation through the Alarm Information screen or Setup menu. |

Table 7.8 Setup Alarms and Messages, with Probable Cause and Corrective Action

| Display Message | Alarm Condition/Cause | Corrective Action |
|-----------------------|---|--|
| Energy Comp Conflict | The minus reject energy limit is equal to or less than the maximum energy compensation value. This alarm occurs in time mode only. | Change the - Reject energy limit or maximum energy compensation through the Alarm Information screen or Setup menu. |
| Energy Comp Conflict | The minus suspect energy limit is equal to or less than the maximum energy compensation value. This alarm occurs in time mode only. | Change the - Suspect energy limit or maximum energy compensation through the Alarm Information screen or Setup menu. |
| Energy Comp Conflict | The minus reject energy limit is equal to or less than the minimum energy compensation value. | Change the - Reject energy limit or minimum energy compensation through the Alarm Information screen or Setup menu. |
| Energy Comp Conflict | The minus suspect energy limit is equal to or less than the minimum energy compensation value. | Change the - Suspect energy limit or energy compensation through the Alarm Information screen or Setup menu. |
| Energy Comp Conflict | The plus energy reject limit is equal to or greater than the energy compensation maximum value | Change the +Reject energy limit or maximum energy compensation through the Alarm Information screen or Setup menu. |
| Energy Comp Conflict | The plus suspect energy limit is equal to or greater than the energy compensation maximum value. | Change the +Suspect energy limit or maximum energy compensation through the Alarm Information screen or Setup menu. |
| Energy Comp Crossed | The energy minimum and maximum settings are crossed. This alarm is only valid when energy compensation is on. | Change the minimum and maximum energy compensation limits through the Alarm Information screen or Setup menu. |
| + - Eng Limit Crossed | The suspect limits for energy that you have entered are reversed. | Change the suspect energy limits through the Alarm Information screen or Setup menu. |
| + - Eng Limit Crossed | The reject limits for energy that you have entered are reversed. | Change the reject energy limits through the Alarm Information screen or Setup menu. |

Table 7.8 Setup Alarms and Messages, with Probable Cause and Corrective Action

| Display Message | Alarm Condition/Cause | Corrective Action |
|---------------------|---|--|
| Eng S/R Limit Cross | The plus reject energy limit is equal to or less than the minus suspect energy limit. | Change the +reject energy limit or - suspect energy limit through the Alarm Information screen or Setup menu. |
| Eng S/R Limit Cross | The plus suspect energy limit is equal to or less than the minus reject energy limit. | Change the +suspect energy limit or - reject energy limit through the Alarm Information screen or Setup menu. |
| Eng S/R Limit Cross | The plus reject energy limit is equal to or less than the plus suspect energy limit. | Change the +reject energy limit or +suspect energy limit through the Alarm Information screen or Setup menu. |
| Eng S/R Limit Cross | The minus reject energy limit is equal to or greater than the minus suspect energy limit. | Change the - reject energy limit or - suspect energy limit through the Alarm Information screen or Setup menu. |
| Force A> Pressure | A force value was selected while the set pressure was 80 psi, then the set pressure was reduced to 60 psi. | A new force value must be entered. |
| Force B> Pressure | The force value was selected while the set pressure was 80 psi, then the set pressure was changed to 60 psi. | The force value must be re-entered. |
| Force/Lmt Conflict | Weld force is equal to or greater than the plus reject weld force limit. This alarm can only occur if force stepping is off. | Either raise the reject limit or lower the weld force. |
| Force/Lmt Conflict | Weld force is equal to or greater than the plus suspect weld force limit. This alarm can only occur if force stepping is off. | Either raise the suspect limit or lower the weld force. |
| Force/Lmt Conflict | Weld force is equal to or less than the minus reject weld force limit. This alarm can only occur if force stepping is off. | Either raise the reject limit or lower the weld force. |

Table 7.8 Setup Alarms and Messages, with Probable Cause and Corrective Action

| Display Message | Alarm Condition/Cause | Corrective Action |
|---------------------|--|---|
| Force/Lmt Conflict | Weld force is equal to or less than the minus suspect weld force limit. This alarm can only occur if force stepping is off. | Either raise the suspect limit or lower the weld force. |
| Force/Lmt Conflict | Force B is equal to or greater than the plus reject weld force limit. This alarm can only occur if force stepping is on. | Either raise the reject limit or lower the force B setting. |
| Force/Lmt Conflict | Force B is equal to or greater than the plus suspect weld force limit. This alarm can only occur if force stepping is on. | Either raise the suspect limit or lower the force B settings. |
| Force/Lmt Conflict | Force B is equal to or less than the minus reject weld force limit. This alarm can only occur if force stepping is on. | Either lower the reject limit or raise force B setting. |
| Force/Lmt Conflict | Force B is equal to or less than the minus suspect weld force limit. This alarm can only occur if force stepping is on. | Either lower the suspect limit or raise the force B setting. |
| Force Step Conflict | The force step at power is equal to or greater than the plus reject peak power limit. This alarm cannot occur in peak power welding mode. | Either raise the reject limit or lower the step at power setting. |
| Force Step Conflict | The force step at power is equal to or greater than the plus suspect peak power limit. This alarm cannot occur in peak power welding mode. | Either raise the suspect limit or lower the step at power setting. |
| Force Step Conflict | The force step at energy is equal to or greater than the plus reject energy limit. This alarm cannot occur in energy welding mode. | Either raise the reject limit or lower the step at energy setting. |
| Force Step Conflict | The force step at energy is equal to or greater than the plus suspect energy limit. This alarm cannot occur in energy welding mode. | Either raise the suspect limit or lower the step at energy setting. |

Table 7.8 Setup Alarms and Messages, with Probable Cause and Corrective Action

| Display Message | Alarm Condition/Cause | Corrective Action |
|---------------------|--|--|
| Force Step Conflict | The force step at distance is equal to or less than the minus reject collapse limit. This alarm cannot occur in collapse welding mode. | Either lower reject limit or raise the step at distance setting. |
| Force Step Conflict | The force step at distance is equal to or less than the minus suspect collapse limit. This alarm cannot occur in collapse welding mode. | Either lower the suspect limit or raise the step at distance setting. |
| Force Step Conflict | The force step at energy is equal to or greater than the plus suspect energy limit. This alarm cannot occur in energy welding mode. | Either raise the suspect limit or the step at energy setting. |
| Force Step Conflict | The force step at collapse distance is equal to or greater than the plus reject collapse limit. This alarm cannot occur in collapse welding mode. | Either raise the reject limit or lower the step at collapse setting. |
| Force Step Conflict | The force step at distance is equal to or greater than the plus suspect collapse limit. This alarm cannot occur in collapse welding mode. | Either raise the suspect limit or lower the step at distance setting. |
| Force Step Conflict | The force step at peak power is equal to or greater than the peak power cutoff value. This alarm can occur in all modes except peak power. | Either raise the peak power cutoff or lower the step at power setting. |
| Force Step Conflict | The force step at peak power is equal to or greater than the peak power setting. This alarm cannot occur in peak power mode only. | Either raise the peak power setting or lower the step at peak power setting. |
| Force Step Conflict | The force step at energy is equal to or greater than the energy setting. This alarm cannot occur in energy mode only. | Either raise the energy setting or lower the step at energy value. |
| Force Step Conflict | The force step at energy is equal to or greater than the maximum energy compensation setting. This alarm will occur in time mode with the energy compensation on only. | Either raise max energy compensation or lower the step at energy setting. |

Table 7.8 Setup Alarms and Messages, with Probable Cause and Corrective Action

| Display Message | Alarm Condition/Cause | Corrective Action |
|-----------------------|--|---|
| Force Step Conflict | The force step at time is equal to or greater than the maximum weld time. This alarm can occur in all weld modes except time. | Either increase the max weld time or lower the step at time setting. |
| Force Step Cutoff | The collapse cutoff distance is equal to or less than the step at collapse distance. This alarm can occur in all welding modes except collapse. | Either decrease the step at collapse distance or increase the collapse cutoff distance. |
| Hold Force > Pressure | The hold force was entered when the set pressure was 80 psi. The pressure was then reduced to 60 psi. Therefore this force can no longer be reached. | Re-enter the hold force value or go into horndown and increase the pressure to 80 psi. |
| No Force Step | The force step at time value was not reached. | Manually inspect the part. If the part is acceptable, turn force stepping off. If the part is not acceptable, you might want to adjust your main parameter. |
| No Force Step | The force step at energy value was not reached. | Manually inspect the part. If the part is acceptable, turn force stepping off. If the part is not acceptable, you might want to adjust your main parameter. |
| No Force Step | The force step at power was not reached. | Manually inspect the part. If the part is acceptable, turn force stepping off. If the part is not acceptable, you might want to adjust your main parameter. |
| No Force Step | The force step at external signal input not received. | Manually inspect the part. If the part is acceptable, turn force stepping off. If the part is not acceptable, you might want to adjust your main parameter. |
| No Force Step | The collapse distance required for the force step not reached. | Manually inspect the part. If the part is acceptable, turn force stepping off. If the part is not acceptable, you might want to adjust your main parameter. |

Table 7.8 Setup Alarms and Messages, with Probable Cause and Corrective Action

| Display Message | Alarm Condition/Cause | Corrective Action |
|-----------------------|---|---|
| Preset Not Available | Preset is recalled via external inputs and the preset is not defined or is not allowed for the control level. | Check control level availability for preset. Preset is not defined. Make sure presets do not exceed 16. |
| Pressure > Weld Force | The weld force cannot be reached because the set pressure is too high. | |
| + - Pwr Limit Crossed | The suspect limits for power that you have entered are reversed. | Change the suspect power limits through the Alarm Information screen or Setup menu. |
| + - Pwr Limit Crossed | The reject limits for power that you have entered are reversed. | Change the reject power limits through the Alarm Information screen or Setup menu. |
| Pwr S/R Limit Cross | The plus reject power limit is equal to or less than the minus suspect power limit. | Change the +reject power limit or - suspect power limit through the Alarm Information screen or Setup menu. |
| Pwr S/R Limit Cross | The plus reject power limit is equal to or less than the plus suspect power limit. | Change the +reject power limit or +suspect power limit through the Alarm Information screen or Setup menu. |
| Pwr S/R Limit Cross | The plus suspect power limit is equal to or less than the minus reject power limit. | Change the +suspect power limit or - reject power limit through the Alarm Information screen or Setup menu. |
| Pwr S/R Limit Cross | The minus reject power limit is equal to or greater than the minus suspect power limit. | Change the - reject power limit or - suspect power limit through the Alarm Information screen or Setup menu. |
| Rapid Trav. Conflict | The rapid traverse distance is equal to or greater than the minus reject absolute limit. | Either increase the reject distance limit or decrease the rapid traverse distance. |
| Rapid Trav. Conflict | The rapid traverse distance is equal to or greater than the minus suspect absolute limit. | Either increase the suspect distance limit or decrease the rapid traverse distance. |
| Rapid Trav. Conflict | The rapid traverse distance is equal to or greater than the plus reject absolute limit. | Either increase the reject distance limit or decrease the rapid traverse distance. |

Table 7.8 Setup Alarms and Messages, with Probable Cause and Corrective Action

| Display Message | Alarm Condition/Cause | Corrective Action |
|----------------------|--|---|
| Rapid Trav. Conflict | The rapid traverse distance is equal to or greater than the plus suspect absolute limit. | Either increase the suspect distance limit or decrease the rapid traverse distance. |
| Rapid Trav. Conflict | The rapid traverse distance is equal to or greater than the plus reject trigger limit. | Either increase the reject distance limit or decrease the rapid traverse distance. |
| Rapid Trav. Conflict | The rapid traverse distance is equal to or greater than the plus suspect trigger limit. | Either increase the suspect distance limit or decrease the rapid traverse distance. |
| Rapid Trav. Conflict | The rapid traverse distance is equal to or greater than the minus reject trigger limit. | Either increase the reject distance limit or decrease the rapid traverse distance. |
| Rapid Trav. Conflict | The rapid traverse distance is equal to or greater than the minus suspect trigger limit. | Either increase the suspect distance limit or decrease the rapid traverse distance. |
| Rapid Trav. Conflict | The rapid traverse distance is equal to or greater than the absolute distance cutoff. This alarm can occur in all weld modes except absolute. | Either increase the absolute cutoff distance or decrease the rapid traverse distance. |
| Rapid Trav. Conflict | The rapid traverse distance is equal to or greater than the absolute distance. This alarm can occur only in the absolute welding mode. | Either increase the absolute cutoff distance or decrease the rapid traverse distance. |
| Sync Setup | The sync input pin and the sync output pin are not both defined. | Define missing sync pin. |
| Ext Signal | Ext Start requires both an input pin and an output pin to function. One of the pins is not defined. | Define both and input and an output pin for the SV Interlock. |
| Sync Setup | The sync input pin and the sync output pin are not both defined. | Define missing sync pin. |
| Sys. Pres. Incorrect | The system pressure is out of tolerance (+/-3 PSI). The pressure is read only after five seconds of idle time while in ready. This alarm does not remove the ready signal because that would prevent entry into horn down. Horndown is the only place where the pressure can be viewed for adjustment. | Go to horndown and adjust the system pressure to either 60 psi (+/- 3 psi) or 80 psi (+/- 3 psi). |

Table 7.8 Setup Alarms and Messages, with Probable Cause and Corrective Action

| Display Message | Alarm Condition/Cause | Corrective Action |
|------------------------|---|---|
| + - Time Limit Crossed | The suspect limits for time that you have entered are reversed. | Change the suspect time limits through the Alarm Information screen or Setup menu. |
| + - Time Limit Crossed | The reject limits for time that you have entered are reversed. | Change the reject time limits through the Alarm Information screen or Setup menu. |
| Time S/R Limit Cross | The plus reject time limit is equal to or less than the minus suspect time limit. | Change the +reject time limit or - suspect time limit through the Alarm Information screen or Setup menu. |
| Time S/R Limit Cross | The plus suspect time is equal to or less than the minus reject time limit. | Change the +suspect time limit or - reject time limit through the Alarm Information screen or Setup menu. |
| Time S/R Limit Cross | The plus reject time limit is equal to or less than the plus suspect time limit. | Change the +reject time limit or +suspect time limit through the Alarm Information screen or Setup menu. |
| Time S/R Limit Cross | The minus reject time limit is equal to or greater than the minus suspect time limit. | Change the - reject time limit or - suspect time limit through the Alarm Information screen or Setup menu. |
| Timeout Conflict | The plus reject time limit is equal to or greater than the maximum timeout value. | Change the +reject time limit or maximum timeout value through the Alarm Information screen or Setup menu. |
| Timeout Conflict | The minus reject time limit is equal to or greater than the maximum timeout value. | Change the - reject time limit or maximum timeout value through the Alarm Information screen or Setup menu. |
| Timeout Conflict | The plus suspect time limit is equal to or greater than the maximum timeout value. | Change the +suspect time limit or maximum timeout value through the Alarm Information screen or Setup menu. |
| Timeout Conflict | The minus suspect time limit is equal to or greater than the maximum timeout value. | Change the +suspect time limit or maximum timeout value through the Alarm Information screen or Setup menu. |

Table 7.8 Setup Alarms and Messages, with Probable Cause and Corrective Action

| Display Message | Alarm Condition/Cause | Corrective Action |
|----------------------------------|--|--|
| Trigger Delay Conflict | External trigger delay has been enabled in weld setup, but no input pin has been defined. | Assign pin in System Configuration Menu. |
| Trigger Delay Conflict | External trigger delay and pretrigger are both on. | Turn one off. |
| Weld Force > pressure | The weld force was entered when the system pressure was 80 psi. The system pressure has been reduced to 60 psi and the requested force cannot be reached. | Re-enter the weld force value or go into horndown and increase the pressure to 80 psi. |
| Invalid Preset Error Code = 1 | Features have been selected that are not valid for this control level. Includes things that could have been selected through host mode or selected by installing a BBR from a higher control level machine. Specific to Error code 1: MPS. | Currently, MPS is not available. |
| Invalid Preset Error Code = 2 | Refer to text in first Invalid Preset entry. Specific to Error code 2: Amplitude stepping on Control Level 1 or 2. | Change the settings in your preset. A cold start may be needed. |
| Invalid Preset Error Code = 3 | Refer to text in first Invalid Preset entry. Specific to Error code 3: Force stepping on Control Level 1, 2, 3 or 4. | Change the settings in your preset. A cold start may be needed. |
| Invalid Preset Error Code = 4 | Refer to text in first Invalid Preset entry. Specific to Error code 4: Using a weld mode not valid for Control Level. | Change the settings in your preset. A cold start may be needed. |
| Invalid Preset Error Code = 5 | Refer to text in first Invalid Preset entry. Specific to Error code 5: Invalid distance. | Change the settings in your preset. A cold start may be needed. |
| Invalid Preset Error Code = 6 | Refer to text in first Invalid Preset entry. Specific to Error code 6: Invalid force. | Change the settings in your preset. A cold start may be needed. |
| Invalid Preset Error Code = 7 | Refer to text in first Invalid Preset entry. Specific to Error code 7: Version incorrect. | Change the settings in your preset. A cold start may be needed. |

Table 7.8 Setup Alarms and Messages, with Probable Cause and Corrective Action

| Display Message | Alarm Condition/Cause | Corrective Action |
|----------------------------------|---|---|
| Invalid Preset Error Code = 8 | Refer to text in first Invalid Preset entry. Specific to Error code 8: Control level or actuator incorrect. | Change the settings in your preset. A cold start may be needed. |
| Invalid Preset Error Code = 9 | Refer to text in first Invalid Preset entry. Specific to Error code 9: No association of DUPS preset to the current COP preset. | Change the settings in your preset. A cold start may be needed. |
| Abs Cutoff Conflict | The absolute cutoff distance is equal to or less than the minus reject absolute limit. | Change the absolute cutoff distance or - reject absolute distance limit through the Alarm Information screen or Setup menu. |
| Abs Cutoff Conflict | The absolute cutoff distance is equal to or less than the minus reject trigger limit. | Change the absolute cutoff distance or - reject trigger distance limit through the Alarm Information screen or Setup menu. |
| Abs Cutoff Conflict | The absolute cutoff distance is equal to or less than the minus suspect absolute limit. | Change the absolute cutoff distance or - suspect absolute distance limit through the Alarm Information screen or Setup menu. |
| Abs Cutoff Conflict | The absolute cutoff distance is equal to or less than the minus suspect trigger limit. | Change the absolute cutoff distance or - suspect trigger distance limit through the Alarm Information screen or Setup menu. |
| Abs Cutoff Conflict | The absolute cutoff distance is equal to or less than the plus reject absolute limit. | Change the absolute cutoff distance or +reject absolute distance limit through the Alarm Information screen or Setup menu. |
| Abs Cutoff Conflict | The absolute cutoff distance is equal to or less than the plus reject trigger limit. | Change the absolute cutoff distance or +reject trigger distance limit through the Alarm Information screen or Setup menu. |

Table 7.8 Setup Alarms and Messages, with Probable Cause and Corrective Action

| Display Message | Alarm Condition/Cause | Corrective Action |
|-----------------------|---|--|
| Abs Cutoff Conflict | The absolute cutoff distance is equal to or less than the plus suspect absolute limit. | Change the absolute cutoff distance or +suspect absolute distance limit through the Alarm Information screen or Setup menu. |
| Abs Cutoff Conflict | The absolute cutoff distance is equal to or less than the plus suspect trigger limit. | Change the absolute cutoff distance or +suspect trigger distance limit through the Alarm Information screen or Setup menu. |
| + - Abs Limit Crossed | The suspect limits for absolute distance that you have entered are reversed. | Change the suspect absolute distance limits through the Alarm Information screen or Setup menu. |
| + - Abs Limit Crossed | The reject limits for absolute distance that you have entered are reversed. | Change the reject absolute distance limits through the Alarm Information screen or Setup menu. |
| Abs S/R Limit Cross | The plus reject absolute distance limit is equal to or less than the minus suspect absolute distance limit. | Change the +reject absolute distance or - suspect absolute distance limit through the Alarm Information screen or Setup menu. |
| Abs S/R Limit Cross | The plus suspect absolute distance limit is equal to or less than the minus reject absolute distance limit. | Change the +suspect absolute distance or - reject absolute distance limit through the Alarm Information screen or Setup menu. |
| Abs S/R Limit Cross | The minus reject absolute distance limit is equal to or greater than the minus suspect absolute distance limit. | Change the - reject absolute distance limit or the - suspect absolute distance limit through the Alarm Information screen or Setup menu. |
| Abs S/R Limit Cross | The plus reject absolute distance limit is equal to or less than the plus suspect absolute distance limit. | Change the +reject absolute distance or +suspect absolute distance limit through the Alarm Information screen or Setup menu. |

Table 7.8 Setup Alarms and Messages, with Probable Cause and Corrective Action

| Display Message | Alarm Condition/Cause | Corrective Action |
|-----------------------|---|--|
| Amp Step Conflict | The amplitude step at collapse value is equal to or greater than the plus reject collapse limit. | Change the amplitude step or +reject collapse distance limit through the Alarm Information screen or Setup menu. |
| Amp Step Conflict | The amplitude step at collapse value is equal to or greater than the plus suspect collapse limit. | Change the amplitude step or +suspect collapse distance limit through the Alarm Information screen or Setup menu. |
| Amp Step Conflict | The amplitude step at collapse value is equal to or greater than collapse cutoff. | Change the amplitude step or collapse cutoff through the Alarm Information screen or Setup menu. |
| Amp Step Conflict | The amplitude step at collapse distance is equal to or greater than the collapse distance. | Change the amplitude step or collapse distance through the Alarm Information screen or Setup menu. |
| + - Col Limit Crossed | The suspect limits for collapse distance that you have entered are reversed. | Change the suspect collapse distance limits through the Alarm Information screen or Setup menu. |
| + - Col Limit Crossed | The reject limits for collapse distance that you have entered are reversed. | Change the reject collapse distance limits through the Alarm Information screen or Setup menu. |
| Col S/R Limit Cross | The plus reject collapse distance limit is equal to or less than the minus suspect collapse distance limit. | Change the +reject collapse distance limit or - suspect collapse distance limit through the Alarm Information screen or Setup menu. |
| Col S/R Limit Cross | The plus suspect collapse distance limit is equal to or less than the minus reject collapse distance limit. | Change the +suspect collapse distance limit or - reject collapse distance limit through the Alarm Information screen or Setup menu. |
| Col S/R Limit Cross | The plus reject collapse distance limit is equal to or less than the plus suspect collapse distance limit. | Change the +reject collapse distance limit or +suspect collapse distance limit through the Alarm Information screen or Setup menu. |
| Col S/R Limit Cross | The minus reject collapse distance limit is equal to or greater than the minus suspect collapse distance limit. | Change the - reject collapse distance limit or - suspect collapse distance limit through the Alarm Information screen or Setup menu. |

Table 7.8 Setup Alarms and Messages, with Probable Cause and Corrective Action

| Display Message | Alarm Condition/Cause | Corrective Action |
|---------------------|---|--|
| Cutoff Conflict | The minus reject collapse limit is equal to or greater than the collapse cutoff value. | Change the - reject collapse limit or collapse cutoff through the Alarm Information screen or Setup menu. |
| Cutoff Conflict | The minus suspect collapse limit is equal to or greater than the collapse cutoff value. | Change the - suspect collapse limit or collapse cutoff through the Alarm Information screen or Setup menu. |
| Cutoff Conflict | The minus reject absolute limit is equal to or greater than the absolute cutoff value. | Change the - Reject absolute limit or absolute cutoff through the Alarm Information screen or Setup menu. |
| Cutoff Conflict | The minus suspect absolute limit is equal to or greater than the absolute cutoff value. | Change the - Suspect absolute limit or absolute cutoff through the Alarm Information screen or Setup menu. |
| + - F Limit Crossed | The minus reject weld force limit is equal to or greater than the plus reject weld force limit. | Change the - reject weld force limit and/or the +reject weld force limit through the Alarm Information screen or Setup menu. |
| + - F Limit Crossed | The minus suspect force limit is equal to or greater than the plus suspect force limit. | Change the - suspect weld force limit and/or the +suspect weld force limit through the Alarm Information screen or Setup menu. |
| + - F Limit Crossed | The + reject freq limit and - reject freq limit values are crossed. | Either make the correction or run a horn scan to automatically correct. This alarm is valid for VGA only. |
| F S/R Limit Cross | The plus reject force limit is equal to or less than the minus suspect force limit. | Change the +reject force limit and/or the - suspect force limit through the Alarm Information screen or Setup menu. |
| F S/R Limit Cross | The plus suspect force limit is equal to or less than the minus reject force limit. | Change the +suspect force limit and/or the - reject force limit through the Alarm Information screen or Setup menu. |

Table 7.8 Setup Alarms and Messages, with Probable Cause and Corrective Action

| Display Message | Alarm Condition/Cause | Corrective Action |
|-----------------------|---|---|
| F S/R Limit Cross | The plus reject force limit is equal to or less than the plus suspect force limit. | Change the +reject force limit and/or the +suspect force limit through the Alarm Information screen or Setup menu. |
| F S/R Limit Cross | The minus reject force limit is equal to or greater than the minus suspect force limit. | Change the - reject force limit and/or the - suspect force limit through the Alarm Information screen or Setup menu. |
| Min Trigger Conflict | The trigger force is set below the minimum allowable value. | Minimum trigger force is changed after the trigger force has been set, or if downloaded via host command. |
| Missing Part Conflict | The missing part minimum is equal to or greater than the missing part maximum setting. | Change the missing part minimum and/or the missing part maximum setting through the Alarm Information screen or Setup menu. |
| Missing Part Conflict | The missing part maximum distance is equal to or less than the minus reject absolute limit. | Change the missing part maximum distance and/or the - reject absolute limit through the Alarm Information screen or Setup menu. |
| Missing Part Conflict | The missing part maximum distance is equal to or less than the minus reject absolute limit. | Change the missing part minimum limit or - reject absolute distance limit through the Alarm Information screen or Setup menu. |
| Missing Part Conflict | The missing part maximum distance is equal to or less than the minus reject trigger limit. | Change the missing part minimum limit or - reject trigger limit through the Alarm Information screen or Setup menu. |
| Missing Part Conflict | The missing part maximum distance is equal to or less than the minus reject trigger limit. | Change the missing part maximum distance or - reject trigger distance limit through the Alarm information screen or Setup menu. |
| Missing Part Conflict | The missing part maximum distance is equal to or less than the plus reject trigger limit. | Change the missing part maximum distance or +reject trigger distance limit through the Alarm information screen or Setup menu. |

Table 7.8 Setup Alarms and Messages, with Probable Cause and Corrective Action

| Display Message | Alarm Condition/Cause | Corrective Action |
|-----------------------|---|---|
| Missing Part Conflict | The missing part minimum distance is equal to or greater than the minus suspect absolute limit. | Change the missing part minimum distance limit or - suspect absolute distance limit through the Alarm Information screen or Setup menu. |
| Missing Part Conflict | The missing part maximum distance is equal to or less than the minus suspect trigger limit. | Change the missing part maximum distance limit or - suspect trigger limit through the Alarm Information screen or Setup menu. |
| Missing Part Conflict | The missing part minimum distance is equal to or greater than the minus suspect trigger limit. | Change the missing part minimum distance limit or - suspect trigger limit through the Alarm Information screen or Setup menu. |
| Missing Part Conflict | The missing part maximum distance is equal to or greater than the plus reject absolute limit. | Change the missing part maximum distance limit or +reject absolute limit through the Alarm Information screen or Setup menu. |
| Missing Part Conflict | The missing part minimum distance is equal to or greater than the plus reject absolute limit. | Change the missing part minimum distance limit or +reject absolute distance limit through the Alarm Information screen or Setup menu. |
| Missing Part Conflict | The missing part minimum distance is equal to or less than the plus reject trigger limit. | Change the missing part minimum distance limit or +reject trigger distance limit through the Alarm Information screen or Setup menu. |
| Missing Part Conflict | The missing part maximum distance is equal to or less than the plus suspect absolute limit. | Change the missing part maximum distance limit or +suspect absolute distance limit through the Alarm Information screen or Setup menu. |
| Missing Part Conflict | The missing part minimum distance is equal to or greater than the plus suspect absolute limit. | Change the missing part minimum distance limit or +suspect absolute distance limit through the Alarm Information screen or Setup menu. |

Table 7.8 Setup Alarms and Messages, with Probable Cause and Corrective Action

| Display Message | Alarm Condition/Cause | Corrective Action |
|-----------------------|---|---|
| Missing Part Conflict | The missing part maximum distance is equal to or less than the plus suspect trigger limit. | Change the missing part maximum distance limit or +suspect trigger distance limit through the Alarm Information screen or Setup menu. |
| Missing Part Conflict | The missing part minimum distance is equal to or greater than the plus suspect trigger limit. | Change the missing part minimum distance limit or +suspect trigger distance limit through the Alarm Information screen or Setup menu. |
| Missing Part Conflict | The missing part minimum distance is equal to or greater than the absolute distance cutoff. | Change the missing part minimum distance limit or absolute cutoff through the Alarm Information screen or Setup menu. |
| Missing Part Conflict | The missing part maximum distance is equal to or greater than the absolute distance cutoff. | Change the missing part maximum distance limit or absolute cutoff through the Alarm Information screen or Setup menu. |
| Missing Part Conflict | The missing part minimum distance is equal to or greater than the absolute distance setting. This alarm occurs in absolute mode only. | Change the missing part minimum distance limit or absolute distance through the Alarm Information screen or Setup menu. |
| Missing Part Conflict | The missing part maximum distance is equal to or greater than the absolute distance setting. This alarm occurs in absolute mode only. | Change the missing part maximum distance limit or absolute distance through the Alarm Information screen or Setup menu. |
| Preset Conflict | Both the external selection of presets and sequencing are turned on. | Turn off one of these. |
| Pretrigger Conflict | The pretrigger distance is equal to or greater than the minus reject absolute limit. | Change the pretrigger distance or - reject absolute limit through the Alarm Information screen or Setup menu. |
| Pretrigger Conflict | The pretrigger distance is equal to or greater than the minus suspect absolute limit. | Change the pretrigger distance or - suspect absolute limit through the Alarm Information screen or Setup menu. |

Table 7.8 Setup Alarms and Messages, with Probable Cause and Corrective Action

| Display Message | Alarm Condition/Cause | Corrective Action |
|---------------------|---|--|
| Pretrigger Conflict | The pretrigger distance is equal to or greater than the plus reject absolute limit. | Change the pretrigger distance or +reject absolute limit through the Alarm Information screen or Setup menu. |
| Pretrigger Conflict | The pretrigger distance is equal to or greater than the plus suspect absolute limit. | Change the pretrigger distance or +suspect trigger limit through the Alarm Information screen or Setup menu. |
| Pretrigger Conflict | The pretrigger distance is equal to or greater than the plus reject trigger limit. | Change the pretrigger distance or +reject trigger limit through the Alarm Information screen or Setup menu. |
| Pretrigger Conflict | The pretrigger distance is equal to or greater than the plus suspect trigger limit. | Change the pretrigger distance or +suspect trigger limit through the Alarm Information screen or Setup menu. |
| Pretrigger Conflict | The pretrigger distance is equal to or greater than the minus reject trigger limit. | Change the pretrigger distance or - reject trigger limit through the Alarm Information screen or Setup menu. |
| Pretrigger Conflict | The pretrigger distance is equal to or greater than the minus suspect trigger limit. | Change the pretrigger distance or - suspect trigger limit through the Alarm Information screen or Setup menu. |
| Pretrigger Conflict | The pretrigger distance is equal to or greater than the absolute cutoff distance. | Change the pretrigger distance or absolute cutoff through the Alarm Information screen or Setup menu. |
| Pretrigger Conflict | The pretrigger distance is equal to or greater than the absolute distance. | Change the pretrigger distance or absolute distance through the Alarm Information screen or Setup menu. |
| - R Trg > - R Abs | The minus reject trigger limit is equal to or greater than the minus reject absolute limit. | Change the - reject trigger limit and/or the - reject absolute limit through the Alarm Information screen or Setup menu. |

Table 7.8 Setup Alarms and Messages, with Probable Cause and Corrective Action

| Display Message | Alarm Condition/Cause | Corrective Action |
|-------------------|--|---|
| + R Trg > +R Abs | The plus reject trigger limit is equal to or greater than the plus reject absolute distance limit. | Change the +reject trigger limit and/or the +reject absolute distance limit through the Alarm Information screen or Setup menu. |
| Trg > Weld Force | The requested trigger force is equal to or greater than the requested weld force. | Either increase the weld force setting or decrease the trigger force setting. |
| - R Trg > Abs | The minus reject trigger limit is greater than or equal to the absolute distance. | Change the - reject trigger limit and/or the absolute distance through the Alarm Information screen or Setup menu. |
| - R Trg > +S Abs | The minus reject trigger limit is greater than or equal to the plus suspect absolute distance limit. | Change the - reject trigger limit and/or the +suspect absolute distance limit through the Alarm Information screen or Setup menu. |
| - R Trg > +R Abs | The minus reject trigger limit is greater than or equal to the plus reject absolute distance limit. | Change the - reject trigger limit and/or the +reject absolute distance limit through the Alarm Information screen or Setup menu. |
| Sequence Empty | Preset sequencing is enabled and a start signal has been received, but there is no sequence defined. | Define sequence. |
| - S Trg > Abs | The minus suspect trigger limit is greater than or equal to the absolute distance. | Change the - suspect trigger limit and/or the absolute distance through the Alarm Information screen or Setup menu. |
| - S Trg > - S Abs | The minus suspect trigger limit value is equal to or greater than the minus suspect absolute distance limit. | Change the - suspect trigger limit and/or the - suspect absolute distance limit through the Alarm Information screen or Setup menu. |
| + S Trg > +S Abs | The plus suspect trigger limit is equal to or greater than the plus suspect absolute limit. | Change the +suspect trigger limit and/or the +suspect absolute limit through the Alarm Information screen or Setup menu. |

Table 7.8 Setup Alarms and Messages, with Probable Cause and Corrective Action

| Display Message | Alarm Condition/Cause | Corrective Action |
|-----------------------|---|--|
| Trg S/R Limit Cross | The plus reject trigger distance limit is equal to or less than the minus suspect trigger distance limit. | Change the +reject trigger limit or - suspect trigger limit through the Alarm Information screen or Setup menu. |
| Trg S/R Limit Cross | The plus suspect trigger distance limit is equal to or less than the minus reject trigger distance limit. | Change the +suspect trigger limit or - reject trigger limit through the Alarm Information screen or Setup menu. |
| Trg S/R Limit Cross | The plus reject trigger distance limit is equal to or less than the plus suspect trigger distance limit. | Change the +reject trigger limit or +suspect trigger limit through the Alarm Information screen or Setup menu. |
| Trg S/R Limit Cross | The minus reject trigger distance limit is equal to or greater than the minus suspect trigger distance limit. | Change the - reject trigger limit or - suspect trigger limit through the Alarm Information screen or Setup menu. |
| + - Trg Limit Crossed | The reject limits for trigger distance that you have entered are reversed. | Change the reject trigger distance limits through the Alarm Information screen or Setup menu. |
| + - Trg Limit Crossed | The suspect limits for trigger distance that you have entered are reversed. | Change the suspect trigger distance limits through the Alarm Information screen or Setup menu. |
| Trg Force Conflict | The trigger force is equal to or greater than the plus suspect weld force limit. | Change the trigger force and/ or the +suspect weld force limit through the Alarm Information screen or Setup menu. |
| Trg Force Conflict | The trigger force is equal to or greater than the plus reject weld force limit. | Change the trigger force and/ or the +reject weld force limit through the Alarm Information screen or Setup menu. |
| - R Trg >- R Abs | The reject lower limit you have set for trigger is less than the lower limit you have set for absolute distance. | Change the reject limits for trigger distance and/or the limits for the absolute distance. |
| + R Trg >+R Abs | The reject upper limit you have set for trigger is greater than the upper limit you have set for absolute distance. | Change the reject limits for trigger distance and/or the limits you have set for absolute distance. |

Table 7.8 Setup Alarms and Messages, with Probable Cause and Corrective Action

| Display Message | Alarm Condition/Cause | Corrective Action |
|-------------------|--|---|
| - S Trg > - S Abs | The suspect lower limit you have set for trigger is less than the lower limit you have set for absolute distance. | Change the suspect limits for trigger distance and/or the limits you have set for absolute distance. |
| + S Trg > +S Abs | The suspect upper limit you have set for trigger is greater than the upper limit you have set for absolute distance. | Change the suspect limits for trigger distance and/or the limits you have set for absolute distance. |
| - S Trg > +S Abs | The minus suspect trigger limit is equal to or greater than the plus suspect absolute limit. | Change the - suspect trigger limit and/or the +suspect absolute limit through the Alarm Information screen or Setup menu. |
| + S Trg > - S Abs | The plus suspect trigger limit is equal to or greater than the plus suspect absolute limit. | Change the +suspect trigger limit and/or the - suspect absolute limit through the Alarm Information screen or Setup menu. |

7.5.7 Overload Alarms

You encounter an overload alarm when your ultrasonic power supply has overloaded. The specific overload that has occurred is indicated by the message on your display or your printer.

The following table details the overload alarms that you can encounter on the 2000X Power Supply. The message on the display panel of the Power Supply is shown in the first column, with the more detailed message that you can print shown in the second column. The third and fourth columns indicate what condition led to the alarm and the corrective action you should take.

If you are using a Digital Power Supply, frequency, phase, current and voltage information is also available for each of the overload alarms listed in [Table 7.9](#).

Table 7.9 Overload Alarms and Messages, with Probable Cause and Corrective Action

| Display Message | Printer Message | Alarm Condition/ Cause | Corrective Action |
|-------------------------|-------------------------|---|---|
| Afterburst Overload | Afterburst Overload | An overload occurred during afterburst. An overload occurred during afterburst. The @ Time and frequency (Freq Chg) is from the start of afterburst. Peak power is at the time of the overload. | Check the stack. Repair/Replace the Power Supply Module. |
| Energy Braking Overload | Energy Braking Overload | UPS overload was detected in hold state. Alarm is called 'Energy Braking' because it could be caused by power supply overload during Energy Braking state, but the state is designed to ignore overloads. | Turn off Energy Braking, and call for application assistance. |
| Pretrigger Overload | Pretrigger Overload | The @Time is from start of pretrigger, the frequency and peak power is at the time of the overload. | Check the stack. Repair/Replace the Power Supply Module. |
| Post Weld Seek O/L | Post Weld Seek Overload | An overload occurred during post weld seek. The @ Time and frequency change (Freq chg) are from the start of seek. The peak power is at the time of the overload. | Check the stack. Repair/Replace the Power Supply Module. |

Table 7.9 Overload Alarms and Messages, with Probable Cause and Corrective Action

| Display Message | Printer Message | Alarm Condition/ Cause | Corrective Action |
|-----------------|-----------------|--|--|
| Weld O/L | Weld Overload | The ultrasonic power supply was overloaded during the weld cycle. The @ Time and frequency change (Freq Chg) are from trigger. Peak power is at the time of the overload. | Check the Peak Power reading in Weld Results. If Peak Power is above 100%, reduce your amplitude and/or force settings. |
| Seek Overload | Seek Overload | The ultrasonic power supply was overloaded during the seek cycle at power up. | Check the stack. Repair/Replace the Power Supply Module. For digital UPS only, check that the stack is properly attached and the RF cable is hooked up. |
| Test Overload | Test Overload | The ultrasonic power supply was overloaded during the test cycle. Pressing Test will clear the overload before the power supply goes into test mode. A new cycle can't be run until reset is pressed, even though test can be pressed again. | Check the stack. Repair/Replace the Power Supply Module. For digital UPS only, check that the stack is properly attached and the RF cable is hooked up. |

7.5.8 Note Alarms

In addition to the previously described alarms there are several Note alarms that the Controls can issue to alert you that an alarm is imminent, or that the cycle ran with authorized modifications.

The following table details the Note alarms you can encounter on the 2000X Power Supply. The message on the display panel of the Power Supply is shown in the first column; the detailed message you can print is in the second column. The third and fourth columns indicate the condition that led to the alarm and the corrective action you should take.

Table 7.10 Note Alarms and Messages, with Probable Cause and Corrective Action

| Display Message | Printer Message | Alarm Condition/ Cause | Corrective Action |
|---------------------|---|--|---|
| Absolute Cutoff | Absolute Distance Cutoff | The absolute cutoff distance that you requested has been reached. | Manually inspect the part. If, with acceptable parts, you repeatedly get this alarm, reset your Absolute cutoff. |
| Act Clr Not Reached | Actuator Clear Distance Not Reached. | The actual absolute distance reached during the weld cycle did not reach the Actuator clear distance that you set. | Using Horn Down to obtain size and distance readings, reset your Actuator Clear Distance to an obtainable value. |
| Act Recal Suggested | For optimum performance re calibrate your Actuator. | A preset has been loaded and calibration should be run. | Calibrate Actuator through Note menu, or calibrate from the Main Menu. |
| Act Recal Suggested | Act Recal Suggested | A preset has been loaded and calibration should be run. | Additional information will not be available if the carriage is not at upper limit, the actuator Novram has failed or the palm buttons are still pressed. This note will be disabled when the preset has been recalled via external preset selection, through the host or sequencing. |

Table 7.10 Note Alarms and Messages, with Probable Cause and Corrective Action

| Display Message | Printer Message | Alarm Condition/ Cause | Corrective Action |
|------------------------|--|--|--|
| Collapse Cutoff | Collapse Cutoff | The collapse cutoff distance you requested has been reached. | Manually inspect the part. If you repeatedly get this alarm with acceptable parts, reset your collapse cutoff. |
| Max Energy Reached | Energy Compensation Maximum Energy Reached | The maximum energy compensation value has been reached. | None. This is only a notice that an adaptive control feature that you programmed is in use. |
| Print Buffer | [No message sent to printer.] | The printer buffer is at 80% of capacity. Cycle rate will slow to allow data to print. | Slow the cycle rate or request less printing. |
| Sonics Disabled | Ultrasonics Disabled by user input | A complete weld cycle has been run but the ultrasonics were disabled by a user defined input. | Remove 24V from Sonics Disable input; undefined Sonics Disable input pin. |
| Time Extended | Weld Time was Extended for Energy Compensation | Weld time has been ex-ended up to 50% for energy compensation. This alarm occurs in Time Mode only. | None. This is only a notice that an adaptive control feature that you programmed is in use. |
| USB Memory Nearly Full | USB Memory Nearly Full | The USB memory stick is over 98% full. At the current rate of storing, this is enough room for less than 100 welds. When full, the welder will stop cycling. | Replace USB memory stick. |

7.6 Service Events

| WARNING | |
|---|---|
|  | <p>Service events should be performed only by qualified individuals. The potential for injury or death exists, as well as that for damage to the equipment (which can include loss of product warranty) or loss of valuable setup information for your application.</p> <p>When servicing the system, the service person(s) can have a need for certain conventional hand tools, and you might need to have the following information for testing or returning the system to service.</p> |

7.6.1 Required Tools

Special tools for the ultrasonic Converter, such as spanner wrenches, are provided with your system. You might also need the following hand tools or service tools:

- six-inch or longer Phillips-head screwdriver with a magnetic tip or screw starter.
- good-quality multi-meter for continuity, AC and DC voltages, and resistance, with insulated test probes.

7.6.2 Voltage Test Points

Remove the cover and pivot the DC Power Supply. See [7.7.6 DC Power Supply](#).

Table 7.11 Voltage Test Points

| DC Power Supply |
|-------------------------|
| TB2-1 to TB2-4 = +12vdc |
| TB2-2 to TB2-4 = -12vdc |
| TB2-3 to TB2-4 = +24vdc |
| TB2-7 to TB2-6 = +5vdc |

7.6.3 Cold Start Procedures

The Power Supply internal memory stores the system default settings and the parameters that you set. It also provides temporary storage to support the Power Supply internal functions. A cold start clears the Weld Setup Menu values and restores them to original factory defaults. It is not necessary to perform a cold start during normal operation and servicing, but you might find a cold start helpful when:

- You suspect the system is not operating properly.
- You want to make a new setup.

Some system memory locations and parameters, such as internal power supply history and serial number information, printer type and printer setup, will not be cleared by these Cold Start procedures.

7.6.3.1 Performing a Cold Start

Select Diagnostics from the Main Menu. Touch the Cold Start button to initiate the Cold Start. The screen will return to Weld Setup when the Cold Start is complete.

| NOTICE | |
|---|---|
|  | Using the Cold Start procedures will erase the current preset and some of the Setup parameters in the System Configuration menu. Be sure you have a record of your setup if you want to retain it. Your settings can be printed if you use the optional printer or you can save them to a preset. |

Refer to Section [6.6.3 Diagnostics Menu](#), menu for additional information about Cold Start.

7.7 Parts Replacement

| CAUTION | |
|---|---|
|  | <p>The 2000X Power Supply contains components that can be degraded or damaged by electrostatic discharge. Always use a Grounded Wriststrap and use a grounded work area when handling or servicing the 2000X Power Supply.</p> <p>In the following paragraphs, you are provided instructions on removing and replacing components. Before you begin to disassemble any parts of the Power Supply, ensure that the Power Supply is turned off, and the main power is disconnected. After the Power Supply cover is removed, wait at least two minutes to allow capacitors to discharge. When necessary, refer to Figure 7.3 Component Location of 2000X Modules and Figure 7.4 Front Panel, Exploded Parts View to help you with these procedures.</p> |

The 2000X Power Supply is designed for a long service life. In the event the system malfunctions, many of the internal components (Modules) are replaceable as a unit. If a particular module has failed, it should be replaced or repaired at a Branson Depot Facility.

The 2000X system is designed with an extensive Alarms Message system. Refer to the list of error messages to assist your troubleshooting. These error codes are described in Section [7.4 Troubleshooting](#).

The following parts are replaceable. Refer to the following views of the Power Supply to see the location of each of these components or modules.

7.7.1 Power Supply Cover

The Cover is held in place with seven screws, three on each side of the case and one on the rear. Lift the rear of the cover up to remove it. The Cover must be in place when the system is operating due to fan-forced ventilation design.

Figure 7.3 Component Location of 2000X Modules

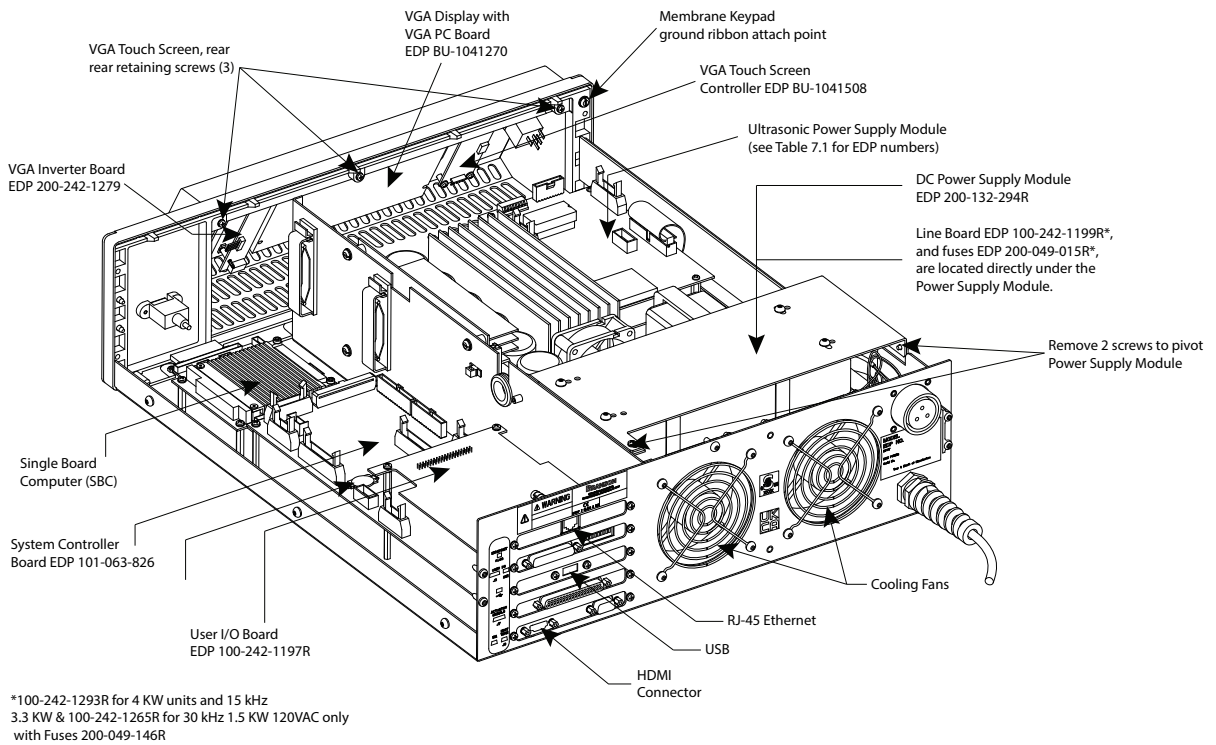
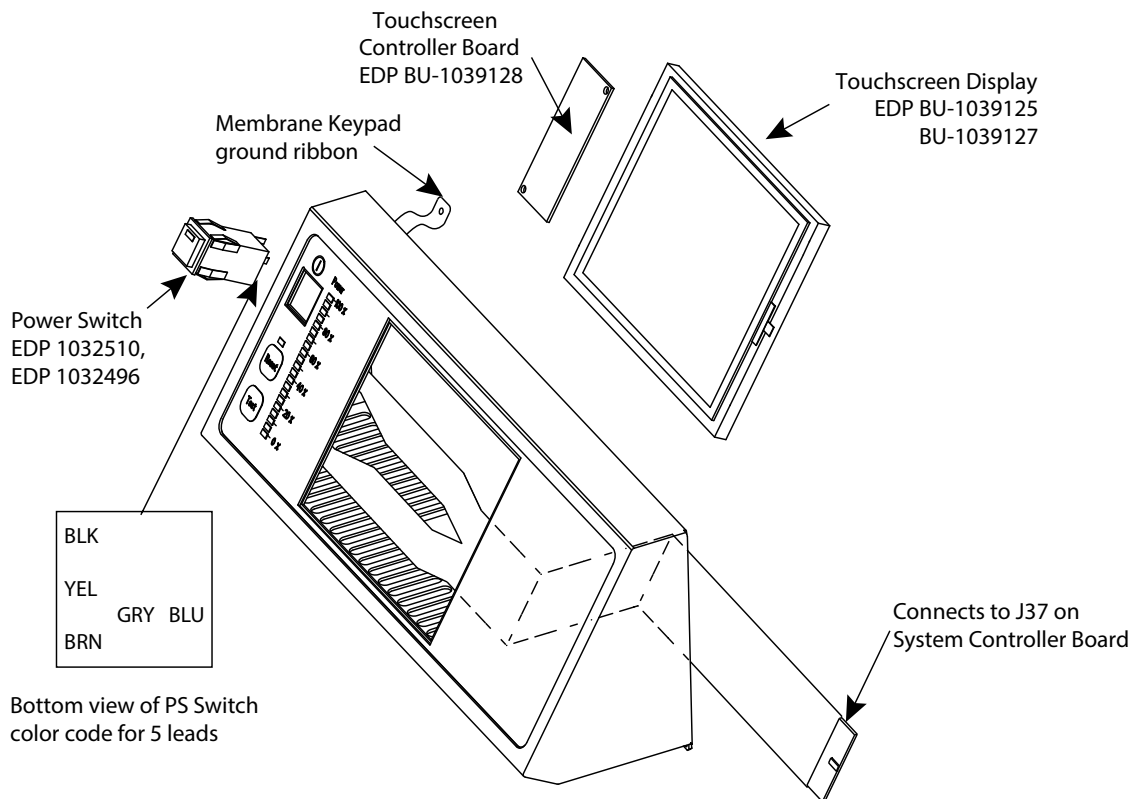

Figure 7.4 Front Panel, Exploded Parts View



7.7.2 Circuit Boards and Modules

Replaceable Modules are shown in [Figure 7.3 Component Location of 2000X Modules](#). Ribbon cables and connectors are unique and keyed to prevent the misconnection of an appropriate connector in a location within the Power Supply case. Fans use identical wiring harnesses, with one tying back the 'extra' lead length.

Make note of any wiring paths if you are removing a module, before you disassemble. In some cases, there are several possible paths, but one preferred location. Be especially careful with harnesses and wires that go between the two portions of the case, as they can be pinched by the metal case if mis-routed.

7.7.3 Power Switch and Lamp

The Power Switch with its integral lamp is a field-replaceable component. It uses a 5-conductor wiring harness.

The switch leads are depicted, by color code, in [Figure 7.4 Front Panel, Exploded Parts View](#), looking at the bottom of the switch. To replace the switch, disconnect power and push the switch out from the rear of the front bezel assembly. Disconnect the wires and, in reverse order, reinstall the new switch with the integral lamp toward the top side.

7.7.4 Front Panel Membrane and Touch Screen Display (VGA)

To remove and replace the Touch Screen Display, take the following steps:

Table 7.12 Removing the Touch Screen Display (VGA)

| Step | Action |
|------|---|
| 1 | Turn off the Power Supply. |
| 2 | Unplug the main power. Allow at least 5 minutes for capacitor discharge. |
| 3 | Using a #2 Philips screwdriver, remove 7 screws from the 2000X Power Supply cover (3 on each side, 1 on the rear). Remove the cover. |
| 4 | Remove: 5 screws at front bottom of VGA unit using a #0 Phillips screwdriver. 3 screws securing the nose assembly from the front, inside, top of the chassis, using a #2 Phillips screwdriver. 1 slotted screw and washer at the top right (from rear) that secures the ground ribbon from the Membrane Keypad. |
| 5 | You will now have access to remove the: VGA Display with VGA PC board VGA Inverter board, and VGA Touch Screen Controller board, as required. |
| 6 | If you need to replace any of the boards from Step 5, please note any details that will be necessary to install the replacement board without damaging the assembly. |
| 7 | To reinstall repaired VGA Assembly, reverse steps being careful not to pinch any wires. |

| NOTICE | |
|---|--|
|  | Be sure the Touch Screen is installed in its original orientation. |

7.7.5 Power Supply Module

The ultrasonic Power Supply Module is affixed to the bottom of the power supply box with four screws through the bottom board. To remove the Power Supply Module, perform the following steps listed in [Table 7.13](#).

| CAUTION | |
|--|--|
|  | <p>Transfer the DIP switch settings from the original module to the new module.</p> <p>If installing a 1.1kw or 800w Power Supply Module into a 117 vac Power Supply, move the 115/230 jumper to the 115 position.</p> |

To remove the Power Supply Module, take the following steps:

Table 7.13 Removing the Power Supply Module

| Step | Action |
|------|--|
| 1 | Turn off the Power Supply. |
| 2 | Unplug the main power. |
| 3 | Allow at least 5 minutes for capacitor discharge. |
| 4 | Using a #2 Phillips screwdriver, remove 7 screws from the 2000X cover (3 on each side, 1 on the rear). Remove the cover. |
| 5 | Disconnect P13, P51, and P60 from controller board. |
| 6 | Disconnect P21 and P24 from the lower board. |
| 7 | Use a Phillips screwdriver to remove retaining screws. |
| 8 | Slide the module out of the Power Supply |

To reinstall the Power Supply Module, reverse the removal procedure.

7.7.6 DC Power Supply

The DC Power Supply is mounted to the rear of the Power Supply case. It is mounted so it will swivel up to service the DC Power Supply, Line Board, and fuses. See [Figure 7.3 Component Location of 2000X Modules](#).

To remove the DC Power Supply, take the following steps:

Table 7.14 Removing the DC Power Supply

| Step | Action |
|------|--|
| 1 | Turn off the Power Supply. |
| 2 | Unplug the main power. |
| 3 | Allow at least 5 minutes for capacitor discharge. |
| 4 | Using a #2 Phillips screwdriver, remove 7 screws from the 2000X cover (3 on each side, 1 on the rear). Remove the cover. |
| 5 | Using a #1 Phillips screwdriver, on the top of the DC Power Supply, remove 1 rear screw. (See Figure 7.3) |
| 6 | Using a #1 Phillips screwdriver, on the left side of the DC Power Supply, remove the rear screw. (See Figure 7.3) |
| 7 | Rotate the DC Power Supply up to allow you access to connectors. |
| 8 | Disconnect the 5-pin connector (J1). |
| 9 | Disconnect the 16-pin connector (J3). |
| 10 | Disconnect pin 3 (red) and pin 4 (black) from TB2 noting the wire colors. |
| 11 | On the top of the DC Power Supply, remove 4 screws. (Note the location of the EMI shield.) |
| 12 | Remove the DC Power Supply. |

To reinstall the DC Power Supply, reverse the removal procedure.

| NOTICE | |
|---|---|
|  | <p>When reconnecting wires, observe the color coding that you previously noted. When installing the connectors, to J1 and J3, ensure the wires from the connectors are turned toward the outside of the unit.</p> |

7.7.7 User I/O Board

The User I/O Board is the short interface board. It is mounted to the System Controller Board on standoffs, and is connected to the rear of the Power Supply case by its end panel.

To remove the User I/O Board, take the following steps:

Table 7.15 Removing the User I/O Board

| Step | Action |
|------|---|
| 1 | Turn off the Power Supply. |
| 2 | Unplug the main power. |
| 3 | Allow at least 5 minutes for capacitor discharge. |
| 4 | Using a #2 Phillips screwdriver, remove 7 screws from the 2000X Power Supply cover (3 on each side, 1 on the rear). Remove the cover. |
| 5 | Disconnect J41. |
| 6 | Using a #1 Phillips screwdriver, remove the 2 end panel screws. |
| 7 | Using a #1 Phillips screwdriver, remove the 2 internal (M3) mounting screws. |
| 8 | Remove the User I/O board. |
| 9 | If the new User I/O Board does not have rear mounting plate, transfer it from the old board. |

To reinstall the User I/O Board, reverse the removal procedure.

7.7.8 Battery for the Backup RAM (BBRAM)

To remove and replace the battery, take the following steps:

Table 7.16 Removing the Battery for the Backup RAM (BBRAM)

| Step | Action |
|------|---|
| 1 | Turn off the Power Supply. |
| 2 | Unplug the main power. Allow at least 5 minutes for capacitor discharge. |
| 3 | Using a #2 Phillips screwdriver, remove 7 screws from the 2000X Power Supply cover (3 on each side, 1 on the rear). Remove the cover. |
| 4 | Remove and replace the battery, located on the controller board. |
| 5 | Replace cover and screws. Plug in main power and turn on the Power Supply. |

| NOTICE | |
|---|--|
|  | When the battery is worn out, dispose it under the ordinance of each local government. |

| NOTICE | |
|---|---|
|  | After replacing battery, re-enter Date, Time, and current preset. |

7.7.9 System Controller Board

To remove the System Controller Board, take the following steps:

Table 7.17 Removing the System Controller Board

| Step | Action |
|------|---|
| 1 | Print out or record all parameters from your weld setup. |
| 2 | Turn the Power Supply off. Disconnect it from Main power. Wait at least 5 minutes for capacitor to discharge. |
| 3 | Using a #2 Phillips screwdriver, remove 7 screws from the 2000X Power Supply cover (3 on each side, 1 on the rear). |
| 4 | Observe all ESD precautions (grounding strap). |
| 5 | Remove the User I/O board. See 7.7.7 User I/O Board . |
| 6 | Remove all cables connected to the system controller. Note the path of the cable routing, and be careful that you do not bend the flexible transparent cable sharply. |
| 7 | Remove all screws and standoffs that hold the System Controller in the chassis, including the 2 (M3) screws in the back panel. |

CAUTION

Do not remove the 2 screws that secure the back panel plate to the D shell connector. If this is a board upgrade, the new level designation is located on the replacement assembly. If there still exists a need to remove the connector, do not apply a torque greater than 4 in/lbs to the screws when reassembling.

| | |
|---|-------------------------------------|
| 8 | Remove the System Controller Board. |
|---|-------------------------------------|

To reinstall the System Controller Board, reverse the removal procedure and perform a Cold Start.

| NOTICE | |
|---|---|
|  | <p>You can verify the software version of your power supply either viewing it in the System Information menu, or by removing the power supply cover and reading the version number on the flash (ICs U53, U54, U55, and U56) located on the Controller Board. Verify that you have the board configuration shown below.</p> |

| CAUTION | |
|---|---|
|  | <p>Do not rely on the paper label for IC orientation.</p> |

The triangle on the IC socket should be directly under the raised dot on the IC. The socket and IC also have a truncated corner to aid in alignment. The raised dot may also be located on the beveled surface of the IC.

Figure 7.5 Location and Orientation of U53, U54, U55, and U56

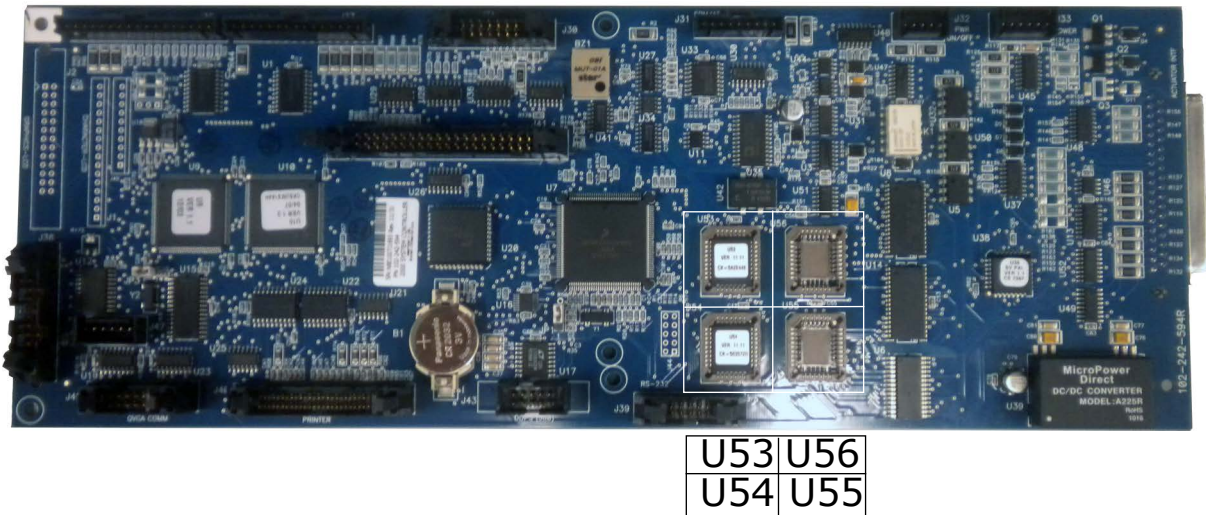

For installation information, contact Branson Product Support by calling the appropriate department as indicated in [Table 1.1 Branson Contacts](#), on Section [1.5.3 Departments to Contact](#).

7.7.10 Single Board Computer (SBC)

To remove the SBC, take the following steps:

Table 7.18 Removing the SBC PC Board

| Step | Action |
|--|---|
| 1 | Turn off the power supply. |
| 2 | Unplug the main power. |
| NOTICE Allow at least 5 minutes for capacitor discharge. | |
| 3 | Using a #2 Phillips screwdriver, remove 7 screws from the 2000X Distance cover (3 on each side, 1 on the rear). Remove the cover. |
| 4 | Disconnect all cables from SBC. |
| 5 | Using a #1 Phillips screwdriver, remove the 4 screws that hold the SBC. |
| 6 | Remove the SBC. |

Figure 7.6 SBC PC Board Connector Layout

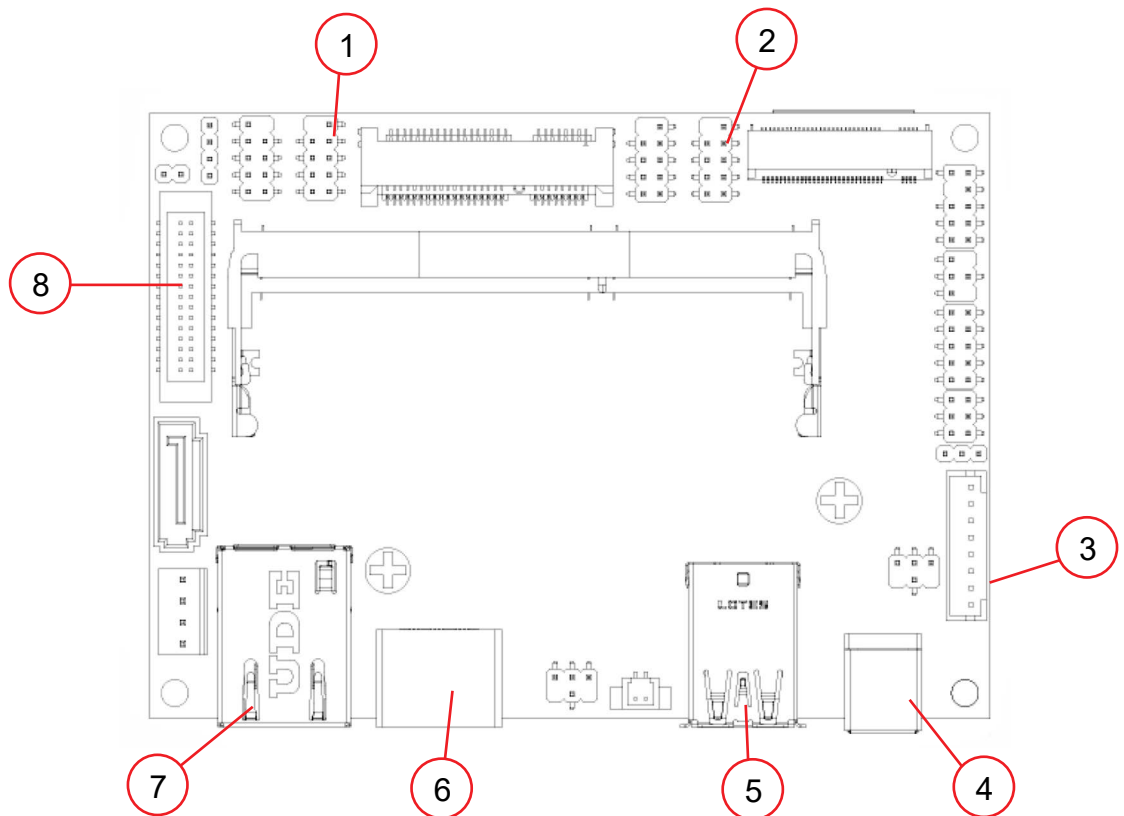

To reinstall the SBC PC board, reverse the removal procedure.

Table 7.19 Reinstalling the SBC Board

| Item | Connect item as shown below |
|------|--|
| 1 | USB3 to front and rear USB Ports. |
| 2 | COM1 to J42 on Weld Controller PCB. |
| 3 | Inverter to J501 on Touchscreen. |
| 4 | DCIN to Power. |
| 5 | USB1 to JP1 on Touchscreen Controller. |
| 6 | HDMI to rear HDMI Port. |
| 7 | LAN1 to J21 on Weld Controller PCB. |
| 8 | LVDS to J001 on Touchscreen. |

| NOTICE | |
|---|---|
|  | <p>When the battery is worn out, dispose it under the ordinance of each local government.</p> |

7.7.11 Line Board

| CAUTION | |
|---|--|
|  | <p>Refer to Figure 7.7 below to verify the voltage selector switch is configured properly for your intended operating voltage.</p> |

Figure 7.7 Lineboard EDP 100-242-1199R*



*100-242-1293R for 4 KW units and 15 kHz 3.3 KW & 100-242-1265R for 30 kHz 1.5 KW 120VAC only)

To remove the Line Board, take the following steps:

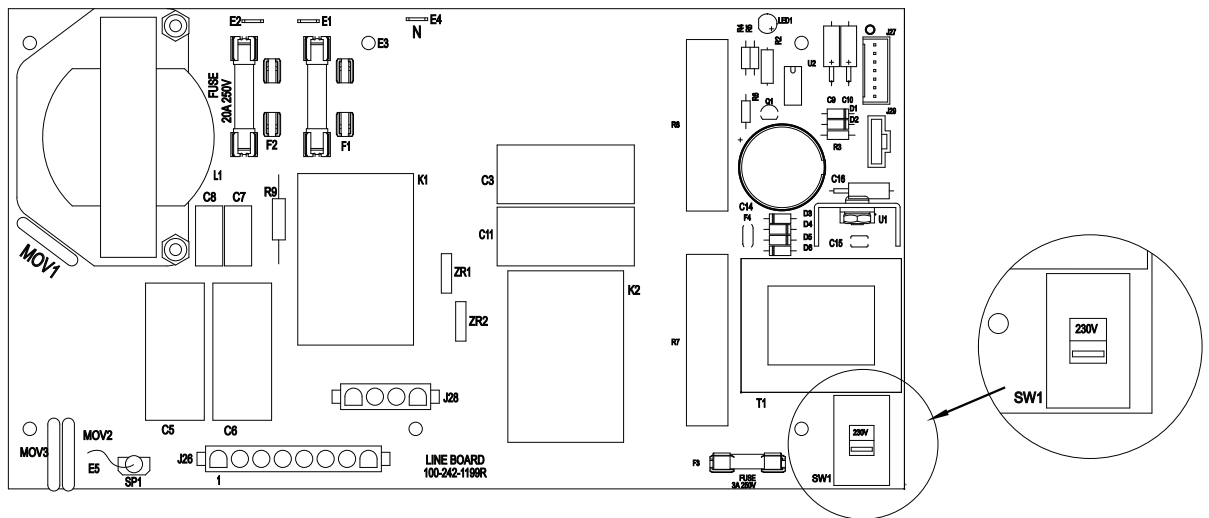
Table 7.20 Removing the Line Board

| Step | Action |
|------|---|
| 1 | Turn off the Power Supply. |
| 2 | Unplug the main power. |
| 3 | Allow at least 5 minutes for capacitor discharge. |
| 4 | Using a #2 Phillips screwdriver, remove 7 screws from the 2000X Power Supply cover (3 on each side, 1 on the rear). Remove the cover. |
| 5 | Rotate the DC Power Supply up to allow you access to the Line Board. See Section 7.7.6 DC Power Supply . |
| 6 | Disconnect J26, J27, J28, and J29. |
| 7 | For 120 V systems, disconnect line labeled E1 and neutral labeled E4 or N. For 220 V systems, disconnect lines labeled E1 and E2. Note that the brown lead is the hot lead. |
| 8 | Remove 5 M3 screws (Phillips) and 1 ground screw (common head). |

Table 7.20 Removing the Line Board

| Step | Action |
|------|--------------------------|
| 9 | Lift out the line board. |

To reinstall the Line Board, reverse the removal procedures.

| CAUTION | |
|---|--|
|  | When reconnecting wires, observe the color coding that you previously noted and the connections noted in step 6 above. |

7.7.12 Line Fuses

To remove and replace the Line Fuses, take the following steps:

Table 7.21 Removing and Replacing the Line Fuses

| Step | Action |
|------|--|
| 1 | Turn off the Power Supply. |
| 2 | Unplug the main power. |
| 3 | Allow at least 5 minutes for capacitor discharge. |
| 4 | Using a #2 Phillips screwdriver, remove 7 screws from the 2000X d cover (3 on each side, 1 on the rear). Remove the cover. |
| 5 | Rotate the DC Power Supply up to allow you access to the Line Board. See 7.7.6 DC Power Supply . |
| 6 | Remove and replace the line fuse(s) located on the Line Board. |

Reassemble the Power Supply by reversing the above procedure.

7.7.13 Cooling Fans

To remove a Cooling Fan, take the following steps:

Table 7.22 Removing a Cooling Fan

| Step | Action |
|------|--|
| 1 | Turn off the Power Supply. |
| 2 | Unplug the main power. |
| 3 | Allow at least 5 minutes for capacitor discharge. |
| 4 | Using a #2 Phillips screwdriver, remove 7 screws from the 2000X cover (3 on each side, 1 on the rear). Remove the cover. |
| 5 | Rotate the DC Power Supply up to allow you access to the Fans. See 7.7.6 DC Power Supply . |
| 6 | Cut the tie-wraps from the fan wiring. |
| 7 | Disconnect the electrical connector(s). |
| 8 | Remove the 4 fan mounting screws and nuts. |
| 9 | Remove the fan and shield. |

To reinstall the a Cooling Fan, reverse the removal procedure while observing the direction of air flow.

| NOTICE | |
|---|--|
|  | <p>Be sure that you reinstall the fan shields on the back of the Power Supply.</p> |

Appendix A: Automation

A.1 FAQ: 2000 Series Automation238

This appendix presents information on automation features, in the form of FAQs, on 2000 Series power supplies.

For additional information about automation, refer to the Branson Automation Guide, EDP 100-214-273. The guide details automation logic requirements, and provides 12 automation examples which include process flows and wiring diagrams to accomplish the respective automation examples.

A.1 FAQ: 2000 Series Automation

Q. What is the best tip for automating a Branson welder?

A. Perhaps the best advice is to provide a "manual jog" function where the welder can be cycled by the system control panel without indexing the whole machine. The time saved debugging, optimizing, calibrating and servicing the welder over its lifetime will pay-back to the end-user and machine builder many times the cost of input hardware and code.

Q. What are the electrical characteristics of the input/output lines in the START and USER I/O cables?

A. They are rated at 10ma. 24Vdc. This is compatible with most PLC's available.

Q. Can't I use 120 volt AC LOGIC?

A. Not directly. Use relays to interface between the 2 logic levels. Note: use relays with lowpower requirement coils, and use back biased diodes to suppress induced back EMF.

Q. But you forgot about the RELAY outputs in your diagrams.

A. They are SOLID STATE relays, and can safely withstand 40 V ac 250 ma, or 24 V dc, 250 ma. So they may be suited better to drive relays, if required to interface to relay coils.

Q. Why do you have so many pins in the USER I/O cable?

A. We combined the alarm and advanced feature connector outputs from the 900 Series with 2000 Series additions to provide maximum features and flexibility while retaining most feature backward compatibility.

Q. What do I do with the UNUSED PINS?

A. You should electrically isolate each unused pin so that shorts to ground and other outputs are avoided. This could possibly damage the USER I/O board and other system components.

Q. Do I ground the shields on the START and USER I/O cables?

A. No; leave the shields from the cables isolated and cut-back so they do not touch ground: this prevents ground loop interference from occurring.

Q. Should I ground the RETURN lines in the START and USER I/O cables?

A. If required: this generally is not a problem. If problems occur, see "OTHER THAN 24 VOLTS".

Q. What are those SQUARE PLASTIC HOUSINGS on the cables?

A. They are ferrites that are used to reduce crosstalk and interference from entering the system. DO NOT remove them.

Q. How LONG can I run the CABLES?

A. Cable sets are available in 8, 15, 25, and on special order 50-foot lengths. Contact Branson Product Support or Customer Service if you have special needs.

Q. Can I run the Branson welder cables in a WIRING TROUGH with other system cables?

A. Generally yes. But it would be best to avoid other noise trouble source cables or wiring.

Q. What other system cables might cause a NOISE TROUBLE SOURCE?

A. Avoid wiring of devices such as solenoids, large relays, motors, or anything that has the potential of large inductive currents. Digital devices may also create broad-spectrum noise. Generally, all automation controls can be noise generators.

Q. Why do you require the READY signal to be monitored by the system PLC?

A. The welder mandatory requirements dictate the unit be READY or else the unit will DISREGARD any start command.

Q. Why can't I use a SINGLE START input to signal the welder?

A. This is not preferable as you are running the signals in parallel, and cable capacitance can reduce the noise immunity designed into the controls. The dual inputs are required for the use of manual start switches, and the necessary circuit needs of an actuator welder utilizing solenoid valve control.

Q. Why must I MAINTAIN THE START SIGNAL?

A. This is the way the built-in safety circuits operate. Also, the vast library of error-detection firmware code is based on these same requirements: it will simplify automation system/PLC/welder debugging during system integration. Watch for the PB RELEASE signal, then you can release the START SIGNAL

Q. My machine is CAM driven. Do I need to do anything special?

A. For one thing, monitor the GENERAL ALARM output and send a RESET as soon as the alarm is received. This will allow the power supply to recover from a fault, and go to READY as soon as possible. Otherwise the next weld may be missed if the system is not reset. Also, see WITHOUT A BRANSON ACTUATOR below.

Q. I'm going to use a welder station WITHOUT A BRANSON ACTUATOR. Do I need to use all those cables?

A. If you only need a "stack" (converter/booster/horn) rather than a full featured actuator, you can use the USER I/O cable. This is a feature available in Version 8.05 operating system. An E-Stop jumper is required to connect Pin 32 (rtn) to pin 13 (source) at J7 on the actuator.

Q. Does it wire up the same way?

A. The USER I/O inputs wire the same way, and the start only needs a SINGLE START input from any available USER I/O input.

Q. But you said you need DUAL START Inputs?

A. Yes, when using a solenoid valve equipped actuator. But in this case we are only controlling ultrasonics. For this function a SINGLE START input works fine.

Q. What can I do to make sure I run at MAXIMUM CYCLE RATE for my machine?

A. You can:

- RESET immediately after an GENERAL ALARM output
- RELEASE the DUAL START inputs immediately after an GENERAL ALARM output
- RELEASE the DUAL START inputs immediately after sensing PB RELEASE output
- If you have a 2000d model: and if the stroke length is more than about 0.5 inches, turn on the ACTUATOR CLEAR function and set the distance value to whatever is required to clear the welded workpiece. Use the ACTUATOR CLEAR output to let your PLC index the material handling, rather than wait for the welder to become READY.
- Never run in an open-loop mode, if possible. Fixed timing can be too short should a fault occur, or may be longer in time than is necessary.

Q. Do all models run at the same CYCLE RATE?

A. See above.

Q. Are there any special requirements for operation with the ACTUATOR UP-SIDE DOWN?

A. Always let Branson know when you plan to run in this manner. Model-specific advice will be provided.

Q. Are there any special requirements for operation with the ACTUATOR HORIZONTAL?

A. Always let Branson know when you plan to run in this manner. Model-specific advice will be provided.

Q. How does EMERGENCY STOP work?

A. Keep in mind that it is meant for EMERGENCY usage only, not for normal head retraction functions. Additional time is allotted for checking the welders' hardware and system status after an EMERGENCY STOP. Note: A front panel or external signal Reset is required after an Emergency Stop to re initialize the welder. Also see CYCLE ABORT below.

Q. So the CYCLE ABORT function is the preferred fast welder head retraction function?

A. Yes. It does not require the additional time that is allotted for checking the welders' hardware and system status that is used for EMERGENCY STOP.

Q. How does RESET work? Can I hold it on?

A. RESET is only acted upon after a GENERAL ALARM. Do not hold it in the RESET state as it will be ignored.

Q. My system logic uses some value OTHER THAN 24 VOLTS. What do I do?

A. A set of dipswitches are provided on the rear panel slot that contains the USER I/O connector. Setting the switches to OFF (open) converts the 24volt USER I/O to OPEN COLLECTOR configuration. The same voltage/current specs apply when in this mode. (24 volt dc,25ma max.) Use them to control devices that have outputs compatible to your requirements.

Q. Are there any environmental conditions to be concerned about?

A. Any electrical/electronic equipment does not work well in: high humidity (condensing) conditions: also in dusty areas, in particular conductive dust (carbon granule or fiber, charcoal, metal particle, etc.). A Fan Filter Kit with instructions can be factory or customer installed for just ordinary dusty areas. Always contact your area representative, Branson Product Support or Customer Service should any like conditions or for inquires about explosion-proof requirements.

Q. How much air consumption does the 2000 Series use?

A. 2000 Series products use identical air cylinder sizes as prior models, therefore the air consumption tables from prior series documentation will still apply.

Cubic Feet of air per Minute per inch of stroke length (each direction)

Table A.1 Air Consumption

| Air Pressure (PSI) | Cylinder Size | | | |
|--------------------|---------------|---------|---------|---------|
| | 1.5 | 2 | 2.5 | 3 |
| 10 | 0.00174 | 0.00317 | 0.00490 | 0.00680 |
| 20 | 0.00243 | 0.00437 | 0.00680 | 0.00960 |
| 30 | 0.00312 | 0.00557 | 0.00870 | 0.01240 |
| 40 | 0.00381 | 0.00677 | 0.01060 | 0.01520 |
| 50 | 0.00450 | 0.00800 | 0.01250 | 0.01800 |
| 60 | 0.00513 | 0.00930 | 0.01440 | 0.02080 |
| 70 | 0.00590 | 0.01040 | 0.01630 | 0.02350 |
| 80 | 0.00660 | 0.01170 | 0.01830 | 0.02670 |
| 90 | 0.00730 | 0.01300 | 0.02040 | 0.02910 |
| 100 | 0.00800 | 0.01420 | 0.02230 | 0.03190 |

Use the above table to calculate the air used by the air cylinder.

Add 0.034 Cubic foot per Second of actual weld time to account for converter cooling air per weld cycle. (2 CFM).

For example:

3.0 inch aed actuator running at full pressure (100psi) and stroke length (4inches) at a cycle rate of 20 parts per minute = 0.0319 CFM per inch of stroke (from above table) X 8 inches (total stroke is 4 inches down and 4 inches back) equals 0.2552 CFM per stroke. Weld time is 1 second so: 0.034 X 1 equals 0.034 CFM for cooling.

Adding 0.2552 CFM for the cylinder and 0.034 CFM for cooling equals 0.2892 CFM per cycle. Multiply for parts per minute (20) and you get a total of 5.784 CFM.

This would very likely be a worst-case condition any welder could run at.

We would suggest to always use the 100 psi values from the above table to be on the conservative side for sizing airflow, rather than on the actual force values. Still add the same converter cooling values (0.034) as in the prior example.

Appendix B: Alarm Index

This alarm index is an alphabetical list of the alarms that appear on the system display and on printouts. In some instances, the alarm display and alarm printouts (more complete) are slightly different, and therefore are indexed separately as appropriate. All alarm page numbers are hyper-linked to the full description, which describes the cause of the alarm condition and the steps to resolve it.

Symbols

| | |
|---|----------|
| - R Abs Dist Limit | 192, 194 |
| - R Col Dist Limit | 194 |
| - R Energy Limit | 193 |
| - R Pk Power Limit | 193 |
| - R Time Limit | 195 |
| - R Trg > - R Abs | 215, 217 |
| - R Trg > + R Abs | 216 |
| - R Trg > + S Abs | 216 |
| - R Trg > Abs | 216 |
| - R Trg Dist Limit..... | 195 |
| - R Weld Force Limit | 195 |
| - Reject Absolute Distance Limit | 192, 194 |
| - Reject Collapse Distance Limit | 194 |
| - Reject Energy Limit | 193 |
| - Reject Peak Power Limit..... | 193 |
| - Reject Time Limit..... | 195 |
| - Reject Trigger Distance Limit..... | 195 |
| - Reject Weld Force Limit | 195 |
| - S Abs Dist Limit | 192 |
| - S Col Dist Limit..... | 196 |
| - S Energy Limit | 193 |
| - S Pk Power Limit | 194 |
| - S Time Limit..... | 196 |
| - S Trg > - S Abs | 216, 218 |
| - S Trg > +S Abs | 218 |
| - S Trg > Abs | 216 |
| - S Trg Dist Limit..... | 196 |
| - S Weld Force Limit | 196 |
| - Suspect Absolute Distance Limit | 192 |
| - Suspect Collapse Dist Limit..... | 196 |
| - Suspect Energy Limit | 193 |
| - Suspect Peak Power Limit..... | 194 |
| - Suspect Time Limit | 196 |
| - Suspect Trigger Distance Limit..... | 196 |
| - Suspect Weld Force Limit | 196 |
| + - Abs Limit Crossed | 209 |
| + - Col Limit Crossed | 210 |
| + - Eng Limit Crossed | 199 |
| + - F Limit Crossed..... | 211 |
| + - Pwr Limit Crossed | 204 |
| + - Time Limit Crossed | 206 |
| + - Trg Limit Crossed | 217 |

| | |
|--|----------|
| + R Abs Dist Limit | 188, 191 |
| + R Col Dist Limit..... | 188 |
| + R Energy Limit | 188, 192 |
| + R Pk Power Limit..... | 189, 193 |
| + R Time Limit..... | 189 |
| + R Trg > +R Abs | 216 |
| + R Trg >+R Abs | 217 |
| + R Trg Dist Limit | 189 |
| + R Weld Force Limit | 189 |
| + Reject Absolute Distance Limit..... | 188, 191 |
| + Reject Collapse Distance Limit | 188 |
| + Reject Energy Limit | 188, 192 |
| + Reject Peak Power Limit..... | 189, 193 |
| + Reject Time Limit | 189 |
| + Reject Trigger Distance Limit..... | 189 |
| + Reject Weld Force Limit | 189 |
| + S Abs Dist Limit | 190, 191 |
| + S Col Dist Limit..... | 188, 190 |
| + S Energy Limit | 190, 192 |
| + S Pk Power Limit..... | 190, 193 |
| + S Time Limit..... | 191 |
| + S Trg > - S Abs | 218 |
| + S Trg > +S Abs | 216, 218 |
| + S Trg Dist Limit | 188, 191 |
| + S Weld Force Limit | 190 |
| + Suspect Absolute Distance Limit..... | 190, 191 |
| + Suspect Collapse Distance Limit..... | 188, 190 |
| + Suspect Energy Limit..... | 190, 192 |
| + Suspect Peak Power Limit | 190, 193 |
| + Suspect Time Limit..... | 191 |
| + Suspect Trigger Distance Limit..... | 188, 191 |
| + Suspect Weld Force Limit | 190 |

A

| | |
|---|---------------|
| Abs Before Trg..... | 186 |
| ABS Cutoff | 177 |
| Abs Cutoff Conflict..... | 208, 209 |
| Abs S/R Limit Cross | 209 |
| Absolute Cutoff | 221 |
| Absolute Distance Before Trigger..... | 186 |
| Absolute Distance Cutoff | 177, 221 |
| Act Clr Not Reached | 221 |
| Act Recal Suggested | 221 |
| Actuator Clear Distance Not Reached | 221 |
| Actuator Clear Function..... | 179 |
| Actuator NovRam | |
| Error Code = 10 | 180 |
| Error Code = 20..... | 180 |
| Error Code = 30..... | 180 |
| Error Code = 40..... | 180 |
| Error Code = 50..... | 180 |
| Error Code = 60..... | 180 |
| Actuator Type..... | 180 |
| Afterburst Overload..... | 219 |
| Amp Step Before Trg (Trigger)..... | 186 |
| Amp Step Conflict | 197, 198, 210 |

C

| | |
|--|----------|
| Col S/R Limit Cross | 210 |
| Collapse Cutoff..... | 222 |
| Collapse Distance for Amplitude Step not Reached | 178 |
| Cutoff Conflict | 198, 211 |

D

| | |
|---------------------------|-----|
| Door/Trigger Switch | 181 |
|---------------------------|-----|

E

| | |
|--|----------|
| Energy Comp Conflict..... | 198, 199 |
| Energy Comp Crossed | 199 |
| Energy Compensation Maximum Energy Reached | 222 |
| Energy Not Reached | 192 |
| Energy Value for Amplitude Step not Reached | 178 |
| Eng S/R Limit Cross | 200 |
| Error Code = 40..... | 180 |
| External signal for Amplitude Step did not occur | 178 |

F

| | |
|--|---------------|
| F S/R Limit Cross | 211 |
| Failure of Preset Data or Battery Backed RAM..... | 181 |
| For optimum performance recalibrate your Actuator..... | 221 |
| Force A> Pressure | 200 |
| Force B> Pressure | 200 |
| Force Step Conflict | 201, 202, 203 |
| Force/Lmt Conflict | 200, 201 |

G

| | |
|--------------------------|----------|
| Ground Detect Abort..... | 177, 187 |
|--------------------------|----------|

H

| | |
|----------------------------|-----|
| Hold Force > Pressure..... | 203 |
| Horn Return Timeout | 181 |

I

| | |
|---------------------|-----|
| Invalid Preset | |
| Error Code = 1..... | 207 |
| Error Code = 2..... | 207 |
| Error Code = 3..... | 207 |
| Error Code = 4..... | 207 |
| Error Code = 5..... | 207 |
| Error Code = 6..... | 207 |
| Error Code = 7..... | 207 |
| Error Code = 8..... | 208 |
| Error Code = 9..... | 208 |

M

| | |
|-----------------------------|---------------|
| Max Energy Reached | 222 |
| Max Timeout..... | 177 |
| Missing Part Abort | 187 |
| Missing Part Conflict | 212, 213, 214 |

N

| | |
|----------------------------------|-----|
| No Amplitude Step | 178 |
| No Force Step | 203 |
| No message sent to printer | 222 |

P

| | |
|--|----------|
| P/S NovRam | 181 |
| Peak Power Cutoff | 179 |
| Post Weld Seek (O/L) Overload | 219 |
| Power level for Amplitude Step not Reached | 178 |
| Power Supply NovRam Failed | 181 |
| Preset Data/BBR | 181 |
| Pressure > Weld Force | 204 |
| Pretrigger Conflict | 214, 215 |
| Pretrigger Overload | 219 |
| Pretrigger Timeout | 182 |
| Print Buffer | 222 |
| Printer Buffer Full | 182 |
| Printer Offline | 182 |
| Pwr S/R Limit Cross | 204 |

R

| | |
|----------------------------|----------|
| Rapid Trav. Conflict | 204, 205 |
| Recalibrate Actuator | |
| Error Code = 100 | 182 |
| Error Code = 200 | 182 |
| Error Code = 300 | 182 |
| Error Code = 400 | 183 |
| Error Code = 600 | 183 |
| Error Code = 700 | 183 |
| Error Code = 800 | 183 |
| Error Code = 900 | 183 |
| Error Code = 1000 | 183 |
| Error Code = 1100 | 184 |
| Error Code = 1200 | 184 |

S

| | |
|--|-----|
| Seek Overload | 220 |
| Start Sw Time | 184 |
| Start Switch Closed (Failure) | 184 |
| Start Switch Stagger Time Missed | 184 |
| Start Switches Lost | 184 |
| Sys. Pres. Incorrect | 205 |

T

| | |
|---|-----|
| Test Overload | 220 |
| The Actuator Type was changed since the last weld cycle | 180 |
| Thermal Overload | 185 |
| Time Extended | 222 |
| Time S/R Limit Cross | 206 |
| Time Value for Amplitude Step not Reached | 178 |
| Timeout Conflict | 206 |
| Trg > Weld Force | 216 |
| Trg Force Conflict | 217 |
| Trg S/R Limit Cross | 217 |

| | |
|--|-----|
| Trig (Trigger) Before Pretrig | 187 |
| Trigger > End Force..... | 179 |
| Trigger Force is greater than the End Force..... | 179 |
| Trigger Lost during Hold | 179 |
| Trigger Lost during Weld | 179 |
| Trigger Lost in Hold | 179 |
| Trigger Lost in Weld..... | 179 |
| Trigger Timeout | 187 |
| U | |
| Ultrasonics P/S | 185 |
| Ultrasonics Power Supply Not Present or Failed..... | 185 |
| Upper Limit Switch | 185 |
| Upper Limit Switch Failed | 185 |
| W | |
| Weld Force > pressure | 207 |
| Weld O/L..... | 220 |
| Weld Overload | 220 |
| Weld Time was Extended for Energy Compensation..... | 222 |
| Wrong Actuator..... | 186 |
| Wrong Actuator AE/AED cannot be used with this level control | 186 |

Appendix C: Manual Revisions

C.1 Manual Revisions250

C.1 Manual Revisions

Refer to the table below for the appropriate manual revision depending on your Power Supply's manufacturing date.

Table C.1 Manual revisions

| Manual Revision | Power Supply Manufacturing Date | |
|-----------------|---------------------------------|----------------|
| | From | To |
| 01 | August 2007 | September 2008 |
| 02 | October 2008 | December 2008 |
| 03 | January 2009 | February 2009 |
| 04 | March 2009 | August 2010 |
| 05, 06, 07 | September 2010 | May 2011 |
| 08 | June 2011 | April 2012 |
| 09 | May 2012 | June 2012 |
| 10 | July 2012 | January 2013 |
| 11 | February 2013 | March 2013 |
| 12 | April 2013 | May 2014 |
| 13, 14, 15 | June 2014 | July 2016 |
| 16 | August 2016 | August 2018 |
| 17 | September 2018 | March 2018 |
| 18 | April 2019 | August 2019 |
| 19, 20 | September 2019 | March 2020 |
| 21 | April 2020 | July 2020 |
| 22 | August 2020 | October 2022 |
| 23 | November 2022 | April 2023 |
| 24 | August 2023 | June 2024 |
| 25 | July 2024 | June 2025 |
| 26 | July 2025 | To date |

Figure C.1 Location of the information Label in the 2000X Distance Power Supply



