



# GSX-E1

## EtherNet/IP

### Automation

# User Guide

**Branson Ultrasonics Corporation**  
120 Park Ridge Road  
Brookfield, CT 06804  
(203) 796-0400  
<http://www.bransonultrasonics.com>

**BRANSON**

[This page intentionally left blank]

## **Manual Change Information**

At Branson, we strive to maintain our position as the leader in ultrasonics plastics joining, metal welding, cleaning and related technologies by continually improving our products. These improvements are incorporated as soon as they are developed and thoroughly tested.

This User Guide is supplemental to and should be used in conjunction with the documentation set for the GSX-E1 system.

Information concerning any improvements will be added to the appropriate technical documentation at its next revision. Therefore, when requesting service assistance for specific units, note the revision information found on this document.

## **Copyright and Trademark Notice**

Copyright © 2025 Branson Ultrasonics Corporation. All rights reserved. Contents of this publication may not be reproduced in any form without the written permission of Branson Ultrasonics Corporation.

[This page intentionally left blank]

---

## **Chapter 1: Introduction**

---

<b>1.1</b>	<b>Configuration Options . . . . .</b>	<b>6</b>
<b>1.2</b>	<b>All-in-One Automation Assembly. . . . .</b>	<b>7</b>
<b>1.3</b>	<b>Column &amp; Hub Mount (Non-Assembled) . . . . .</b>	<b>8</b>
<b>1.4</b>	<b>No Mount (Non-Assembled) . . . . .</b>	<b>9</b>
<b>1.5</b>	<b>Actuator, Power Supply, Auxiliary Box Configurations . . . . .</b>	<b>10</b>
<b>1.6</b>	<b>Declaration of Incorporation . . . . .</b>	<b>13</b>

## 1.1 Configuration Options

Figure 1.1 Configuration Options

### All-in-One Automation Assembly

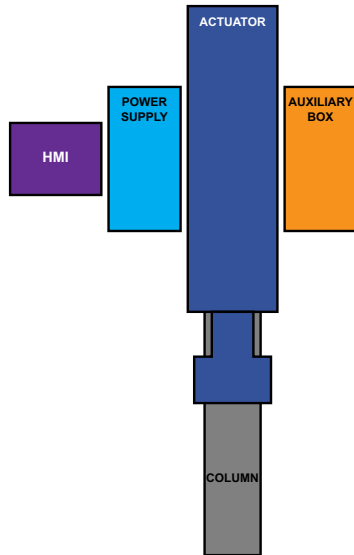

### Column Mount Non-Assembled

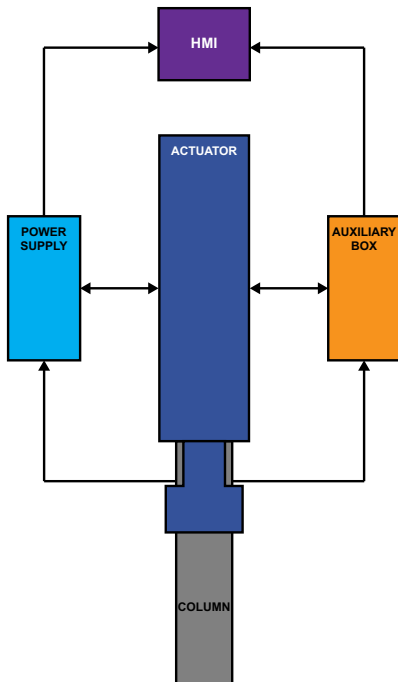

### No Mount Non-Assembled

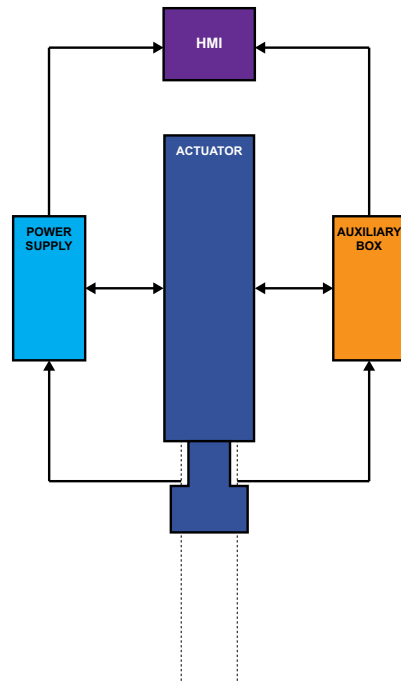

## 1.2 All-in-One Automation Assembly

**Figure 1.2** All-in-One Automation Assembly

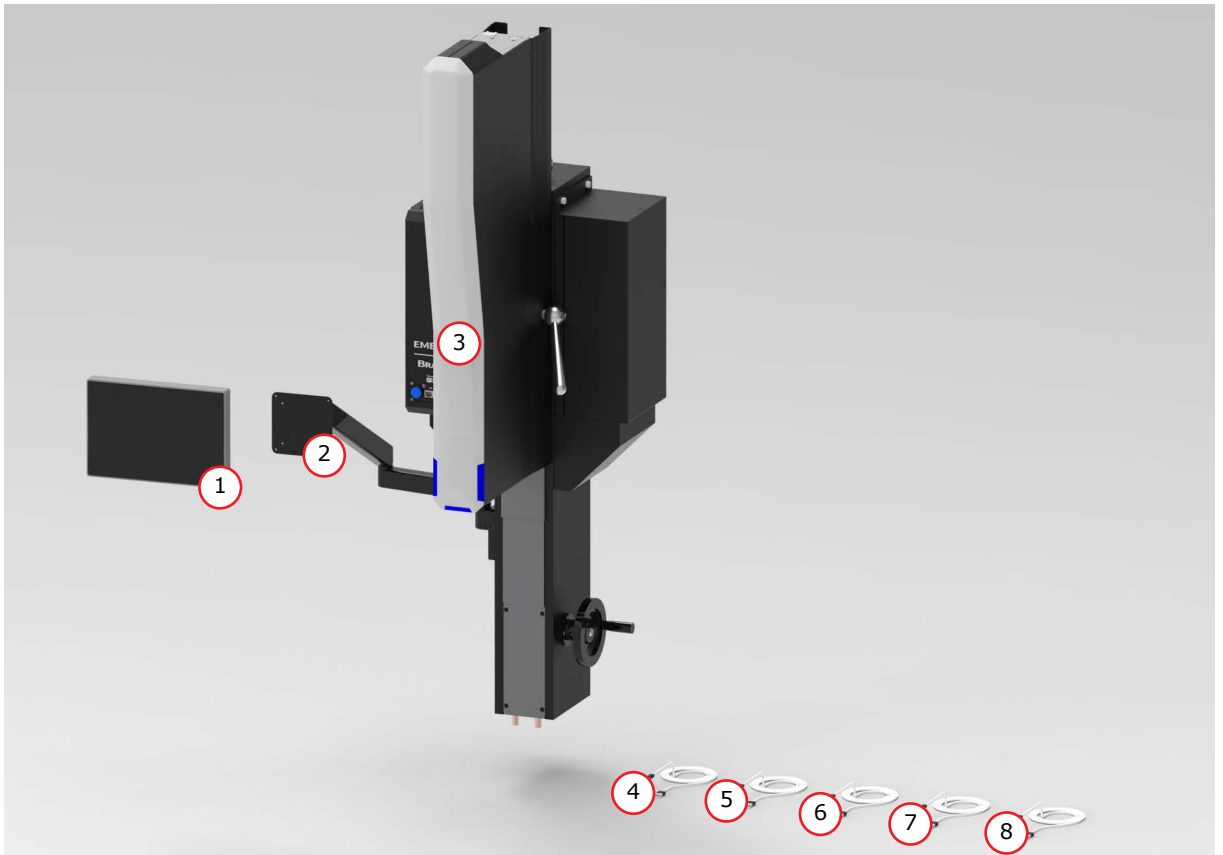
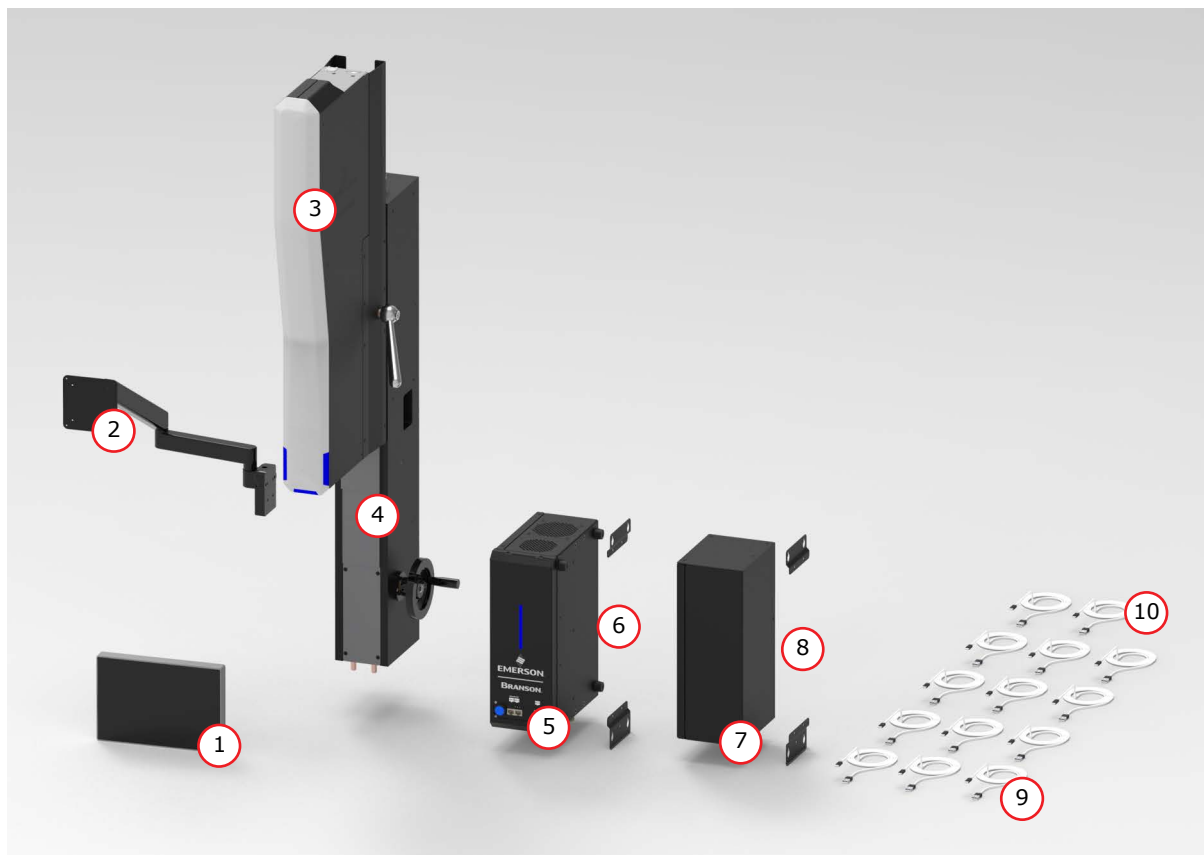

**Table 1.1** All-in-One Automation Assembly

Item	Description	Quantity
1	HMI Monitor	1
2	Monitor Arm	1
3	GSX-E1 All-In-One System	1
4	Actuator I/O Cable	1
5	Power Supply I/O Cable	1
6	Power Supply Line Cord	1
7	Start Cable	1
8	Ground Detect Cable (optional)	-

## 1.3 Column & Hub Mount (Non-Assembled)

**Figure 1.3** Column & Hub Mount (Non-Assembled)



**Table 1.2** Column & Hub Mount (Non-Assembled)

Item	Description	Quantity
1	HMI Monitor	1
2	Monitor Arm (optional)	-
3	Actuator*	1
4	Column	1
5	Power Supply*	1
6	Power Supply Mounting Bracket	2
7	Auxiliary Box*	1
8	Auxiliary Box Mounting Brackets	2
9	Cables (see <a href="#">Table 2.1</a> for more information)	13
10	Ground Detect Cable (optional)	-

### NOTICE



\*There are two different configurations for the actuator, power supply, and auxiliary box. See section [1.5 Actuator, Power Supply, Auxiliary Box Configurations](#) for more information.

## 1.4 No Mount (Non-Assembled)

Figure 1.4 No Mount (Non-Assembled)

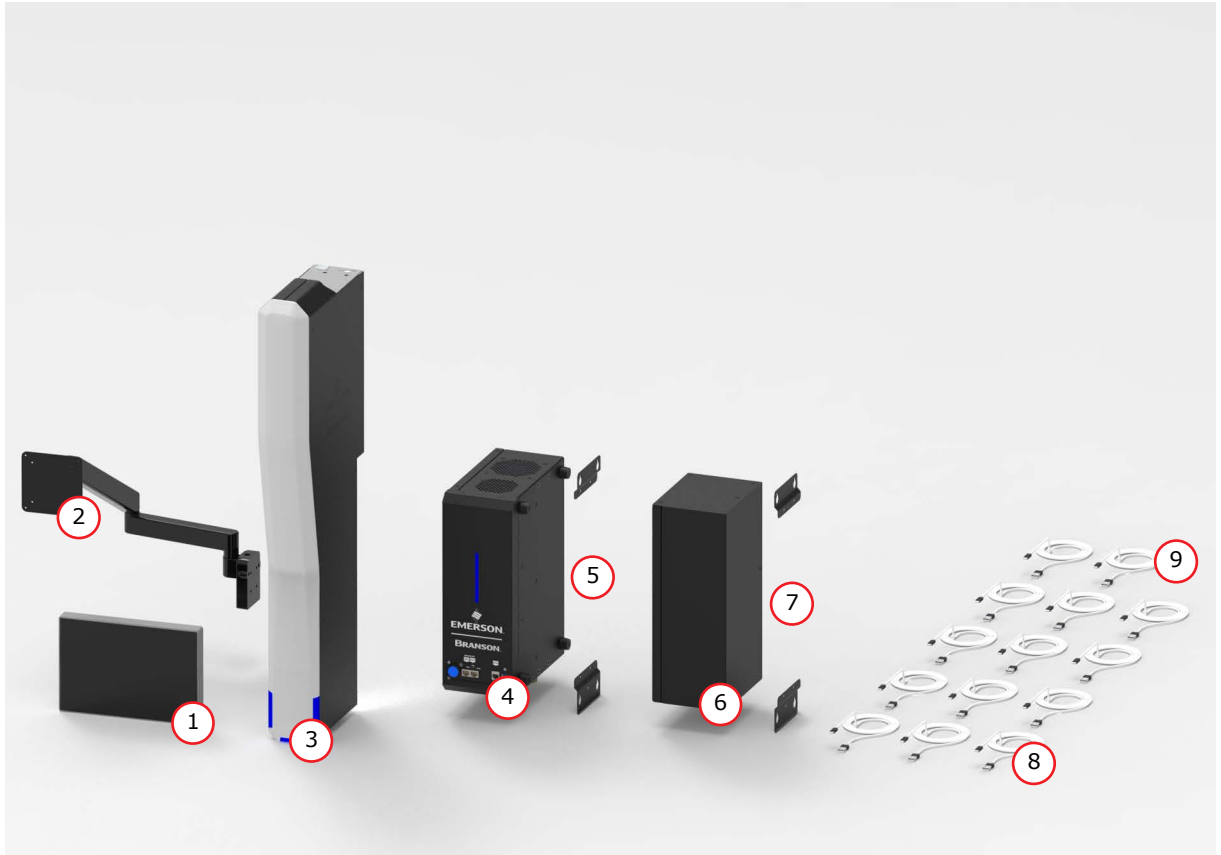

Table 1.3 No Mount (Non-Assembled)

Item	Description	Quantity
1	HMI Monitor	1
2	Monitor Arm (optional)	-
3	Actuator*	1
4	Power Supply*	1
5	Power Supply Mounting Bracket	2
6	Auxiliary Box*	1
7	Auxiliary Box Mounting Brackets	2
8	Cables (see <a href="#">Table 2.1</a> for more information)	13
9	Ground Detect Cable (optional)	-

### NOTICE



\*There are two different configurations for the actuator, power supply, and auxiliary box. See section [1.5 Actuator, Power Supply, Auxiliary Box Configurations](#) for more information.

## 1.5 Actuator, Power Supply, Auxiliary Box Configurations

### 1.5.1 Actuator Configurations

#### 1.5.1.1 Top Exit

Actuator with connections on top of the unit.

**Figure 1.5** Actuator Configurations - Top Exit

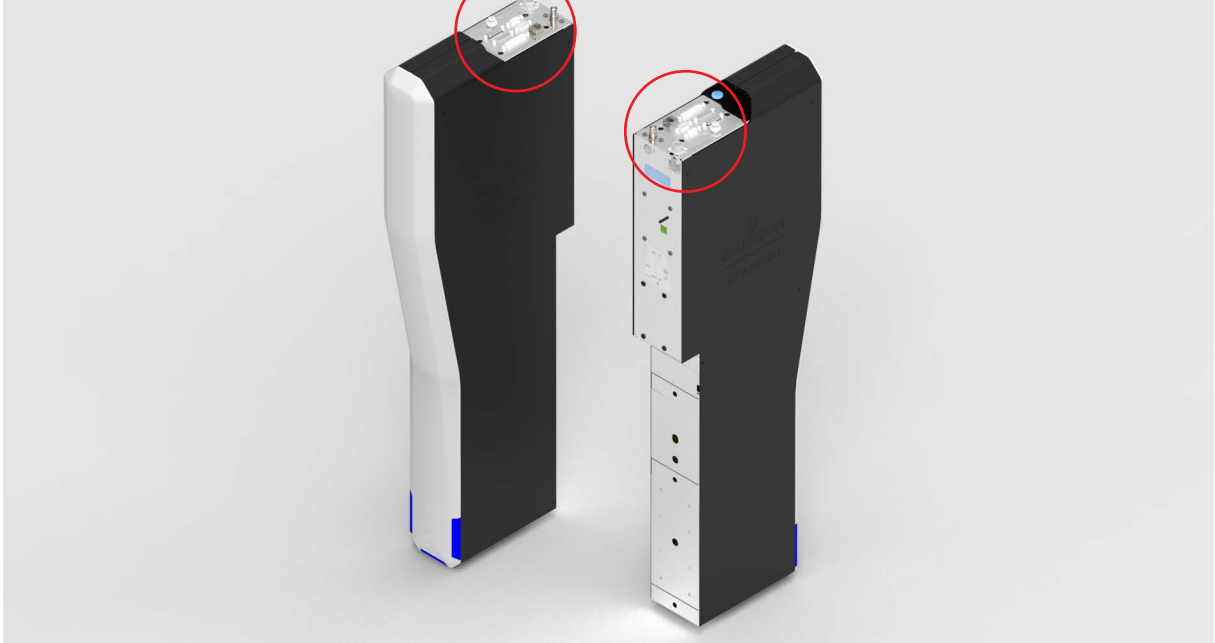

#### 1.5.1.2 Rear Exit

Actuator with connections on the back of the unit.

**Figure 1.6** Actuator Configurations - Rear Exit

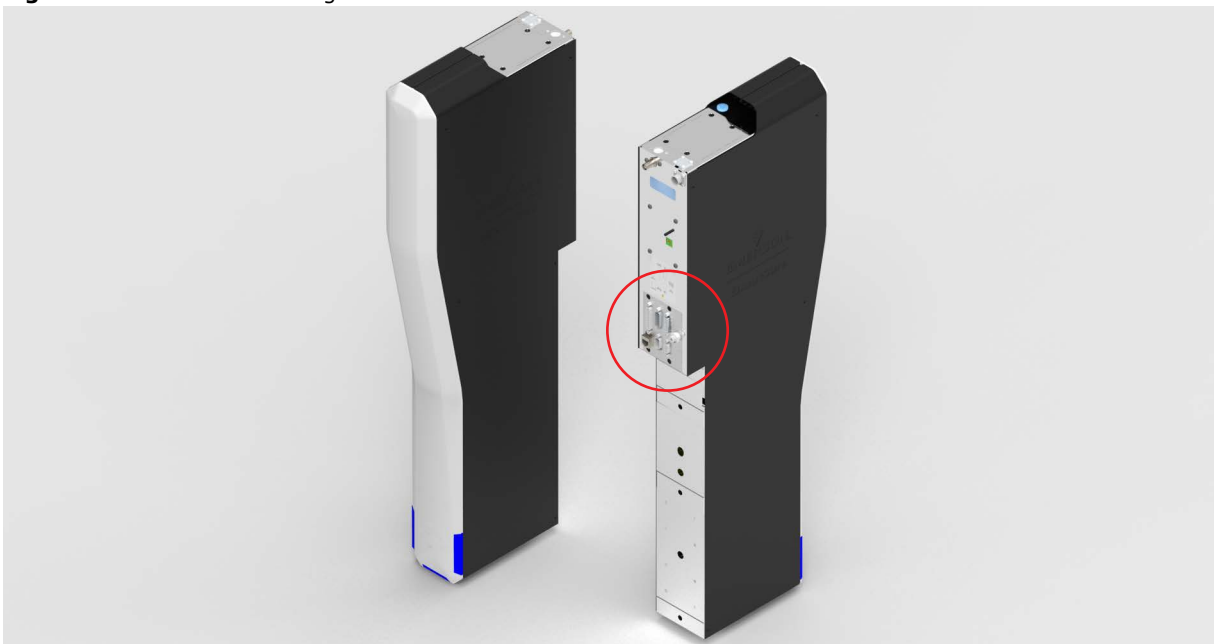

## 1.5.2 Power Supply Configurations

### 1.5.2.1 Bottom Exit

Power supply with connections on the bottom of the unit.

**Figure 1.7** Power Supply Configurations - Bottom Exit



### 1.5.2.2 Rear Exit

Power supply with connections on the back of the unit.

**Figure 1.8** Power Supply Configurations - Rear Exit



## 1.5.3 Auxiliary Box Configurations

### 1.5.3.1 Bottom Exit

Auxiliary box with connections on the bottom of the unit.

**Figure 1.9** Auxiliary Box Configurations - Bottom Exit



### 1.5.3.2 Rear Exit

Auxiliary box with connections on the back of the unit.

**Figure 1.10** Auxiliary Box Configurations - Rear Exit



## 1.6 Declaration of Incorporation

Figure 1.11 Declaration of Incorporation

DocuSign Envelope ID: A374A0B1-EF34-4924-A34A-E45EB05B8C4A

**EC DECLARATION OF INCORPORATION**  
According to Machinery Directive 2006/42/EC, Annex II B

We, the manufacturer

**BRANSON ULTRASONICS CORPORATION**  
120 Park Ridge Road.  
Brookfield, CT 06804  
USA

declare under our sole responsibility, that all relevant essential requirements of the 2006/42/EC Machinery Directive are applied to the partly completed machinery identified in this document, except the protective devices (safety and emergency interlock) which need to be applied by the final integrator.

**Partly completed machinery:** Ultrasonic Welding System model:

GSX-BT-E1 (20:1.25, 20:2.5, 20:4.0, 30:1.5 or 40:0.8)  
GSX-E1 EIP (20:1.25, 20:2.5, 20:4.0, 30:1.5 or 40:0.8) BT

Serial Number: PPPYYMMXXXXR

Where: PPP=Prefix (LHD, LHE, LHP, LHR, LHS, LFH, LFI, LFJ, LFL, LFN, LIP, LIQ, LIR, LIS, LIT, LJC, LJD, LJE, LJF or LJG)  
YY=Year, MM=Month, XXXX=Sequential Number, R=Revision (A, B, C...Z)  
Manufacturing date: March 2024 or later

used with converter model: CJ20, CA30 or 4TJ, and associated cables.

The safety objectives set out in the Low Voltage Directive 2014/35/EU were kept in accordance Annex 1 No. 1.5.1 of the Machinery Directive 2006/42/EC.

The object of this declaration is in conformity with relevant Union harmonization legislation. The equipment, to which this declaration relates, is in conformity with the following standards:

EN 61010-1:2010+A1:2019, EN 60204-1:2018, EN ISO 12100:2010, EN 55011:2016/A11:2020, EN 61000-6-2:2019  
EN ISO 13849-1:2015, EN ISO 13849-2:2012.

We are committing to present any information relevant to health and safety and, in particular, the relevant technical documentation, in response to a duly reasoned request from the market surveillance authorities of one of the Member States.

**IT IS FORBIDDEN TO PUT THIS EQUIPMENT INTO SERVICE UNTIL THE MACHINERY INTO WHICH IT IS TO BE INCORPORATED HAS BEEN DECLARED IN CONFORMITY WITH THE PROVISIONS OF THE MACHINERY DIRECTIVE**

Person authorised to compile the relevant technical documentation:

**BRANSON ULTRASONICS, a.s.**  
Piestanska 1202  
915 01 Nove Mesto nad Vahom  
Slovak Republic

Brookfield, CT, USA  
March 26, 2024

DocuSigned by:  
*Luis Benavides*  
018235BFCE147C...

Luis Benavides  
Sr. Engineering Manager / Product Safety Officer

[This page intentionally left blank]

---

## **Chapter 2: Interconnection**

---

<b>2.1</b>	<b>Interconnection Diagram &amp; Cables . . . . .</b>	<b>16</b>
<b>2.2</b>	<b>Cable Interface Points . . . . .</b>	<b>21</b>

## 2.1 Interconnection Diagram & Cables

Figure 2.1 Interconnection Diagram - 01

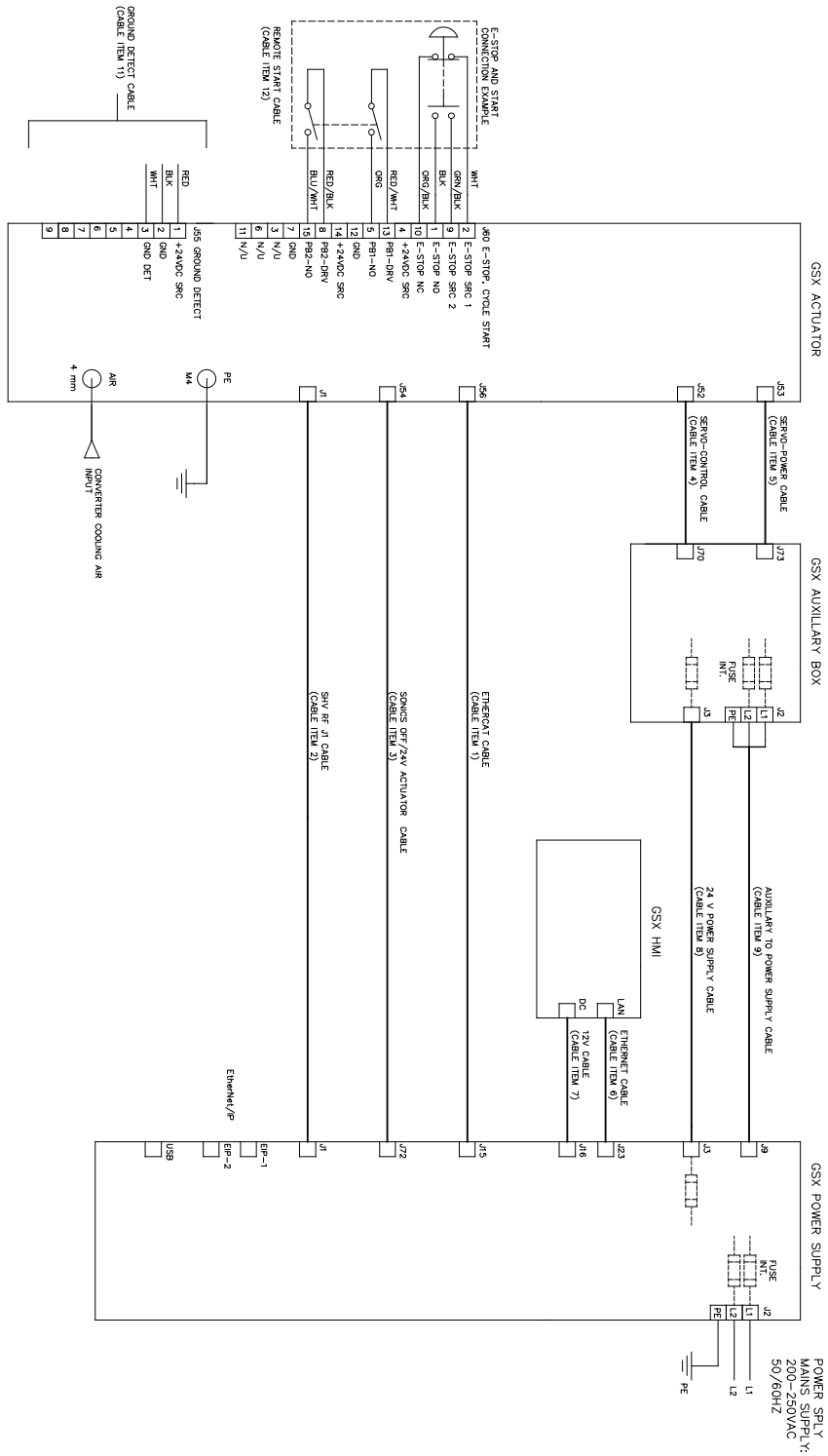

**Figure 2.2** Interconnection Diagram - 02

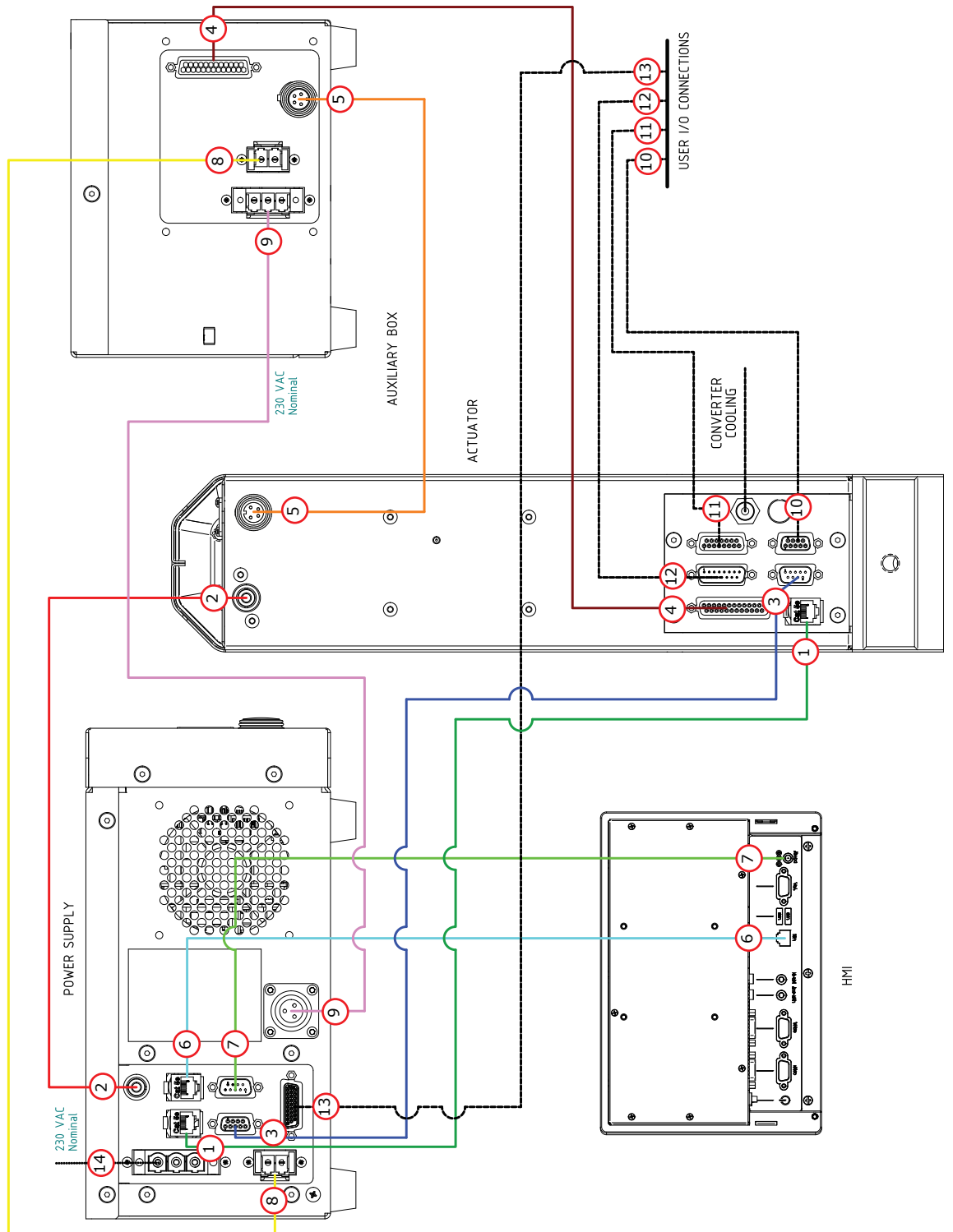

**NOTICE**



For detailed pin-out information, please refer to the GSX-E1 User Manual (EDP 1032609).



**Table 2.1** Interconnection Cables

Item	EDP	Length	Description	Connection Points	Reference
1	1018644	2.5 m	Communication Cable	Actuator J56 - Power Supply J15	
	1018645	7.5 m			
	1018646	15 m			
2	100-240-383	2.5 m	SHV RF J1 Cable	Actuator J1 - Power Supply J1	
	100-240-385	7.5 m			
	100-240-386	15 m			
3	1030041	2.5 m	Sonics Off/24 V Actuator Cable	Actuator J54 - Power Supply J72	
	1030042	7.5 m			
	1030043	15 m			
4	1018558	2.5 m	Servo-Control Cable	Actuator J52 - Auxiliary Box J70	
	1018559	7.5 m			
	1018561	15 m			
5	1033941	2.5 m	Servo-Power Cable	Actuator J53 - Auxiliary J73	
	1033942	7.5 m			
	1033943	15 m			

**Table 2.1** Interconnection Cables

Item	EDP	Length	Description	Connection Points	Reference
6	1018648	2.5 m	Ethernet Cable	Power Supply J23 - HMI LAN Port	
	1018649	7.5 m			
	1018650	15 m			
7	1029730	2.5 m	12 V HMI Cable	Power Supply J16 - HMI DC Input	
	1029731	7.5 m			
	1029732	15 m			
8	1018652	2.5 m	24 V Power Supply Cable	Auxiliary Box J3 - Power Supply J3	
	1018653	7.5 m			
	1018654	15 m			
9	1031348	2.5 m	Auxiliary Box to Power Supply Cable	Auxiliary Box J2 - Power Supply J9	
	1031349	7.5 m			
	1031350	15 m			
10*	1018466	2.5 m	Ground Detect Cable <b>NOTICE</b> *Optional	Actuator J55	
	1018467	7.5 m			
	1018468	15 m			

**Table 2.1** Interconnection Cables

Item	EDP	Length	Description	Connection Points	Reference
11	1017955	2.5 m	Remote Start Cable	Actuator J60	
	1017956	7.5 m			
	1017957	15 m			
12	1014991	3 m	Power Supply Line Cord	Power Supply J2	

## 2.2 Cable Interface Points

### 2.2.1 Actuator

**Figure 2.3** GSX-E1 Actuator Cable Interface Points

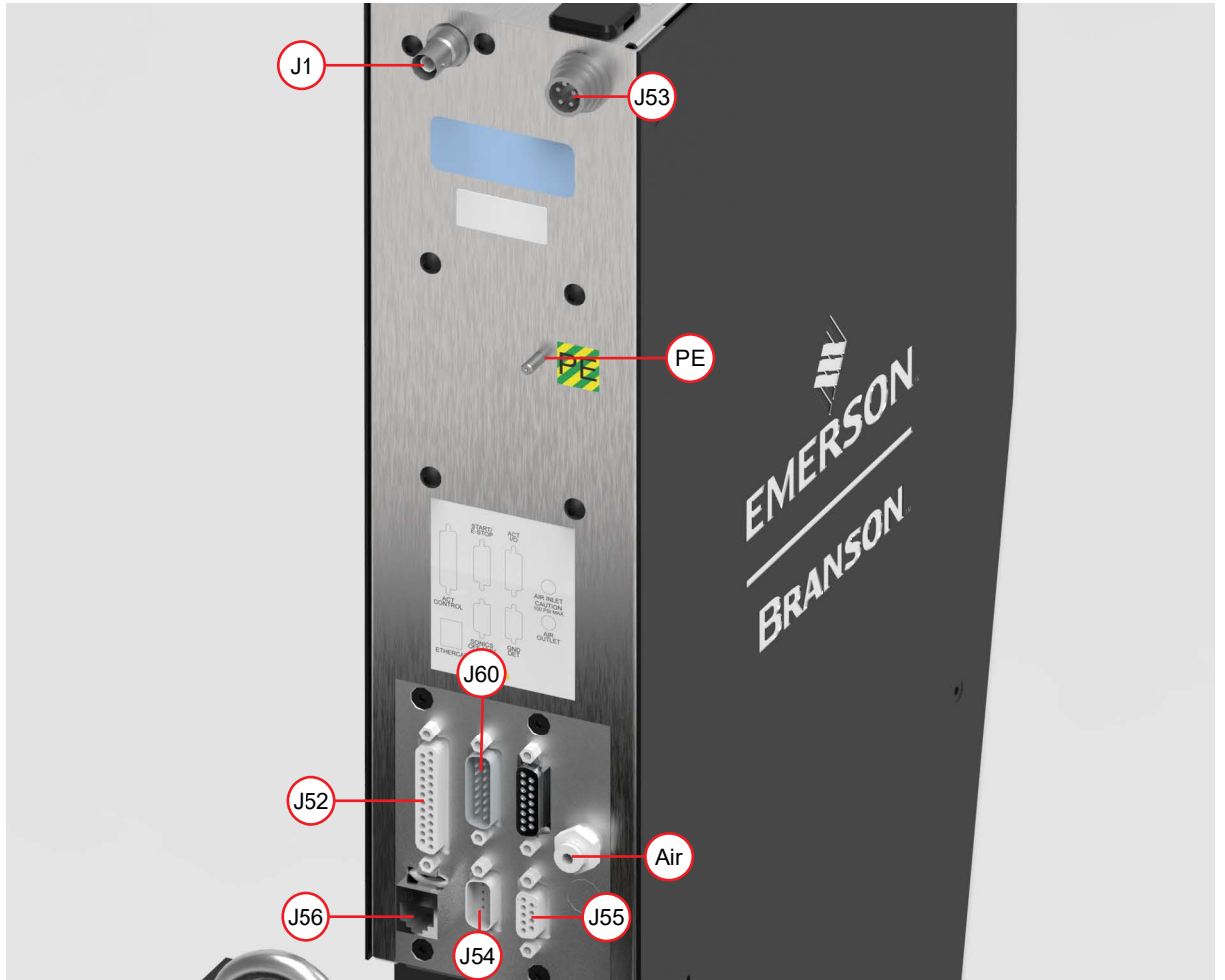

**Table 2.2** GSX-E1 Actuator Cable Interface Points

Connection Point	Description	Cable Required/Notes
J1	RF In	SHV RF J1 Cable
J52	Servo Control	Servo-Control Cable
J53	Servo Power In	Servo-Power Cable
J54	Sonics Status In/24 VDC Actuator In	Sonics Off/24 V Actuator Cable
J55	Ground Detect	Ground Detect Cable
J56	P/S-Actuator Comm	Communication Cable
J60	E-Stop, Cycle Start	Remote Start Cable
PE	Earth Ground	Ground Actuator - M4 stud
Air	Converter Cooling Air Input	Air Fitting - 4 mm tube

## 2.2.2 Power Supply

**Figure 2.4** GSX-E1 Power Supply Cable Interface Points

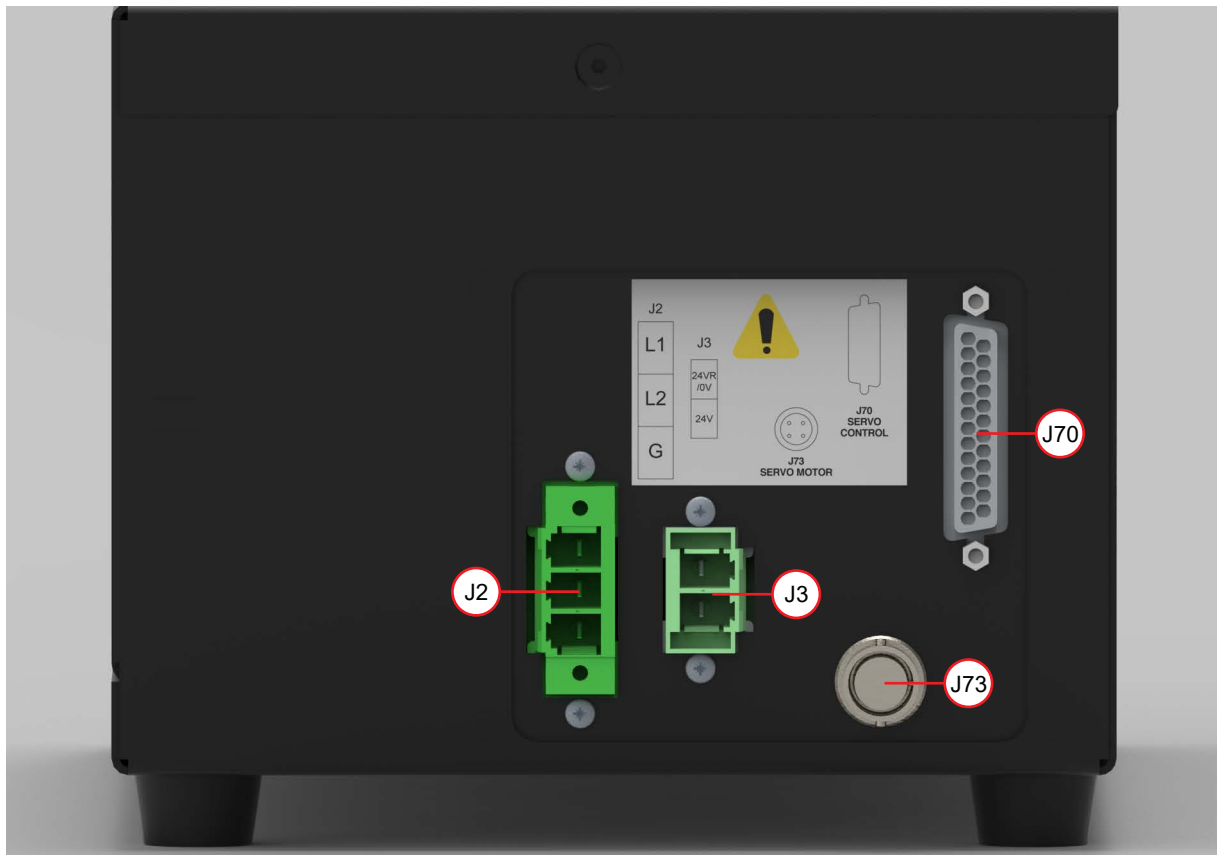

**Table 2.3** GSX-E1 Power Supply Cable Interface Points

Connection Point	Description	Cable Required/Notes
J1	RF Out	SHV RF J1 Cable
J2	Main Supply Voltage Input	Power Supply Line Cord
J3	24 VDC Power Supply In	24 V Power Supply Cable
J9	Auxiliary Box AC Supply	Auxiliary Box to Power Supply
J15	P/S-Actuator Comm	Communication Cable
J16	12 VDC HMI Out	12 V HMI Cable
J23	Ethernet Monitor	Ethernet Cable
J72	24 VDC Actuator Out	Sonics Off/24 V Actuator Cable

## 2.2.3 Auxiliary Box

**Figure 2.5** GSX-E1 Auxiliary Box Cable Interface Points

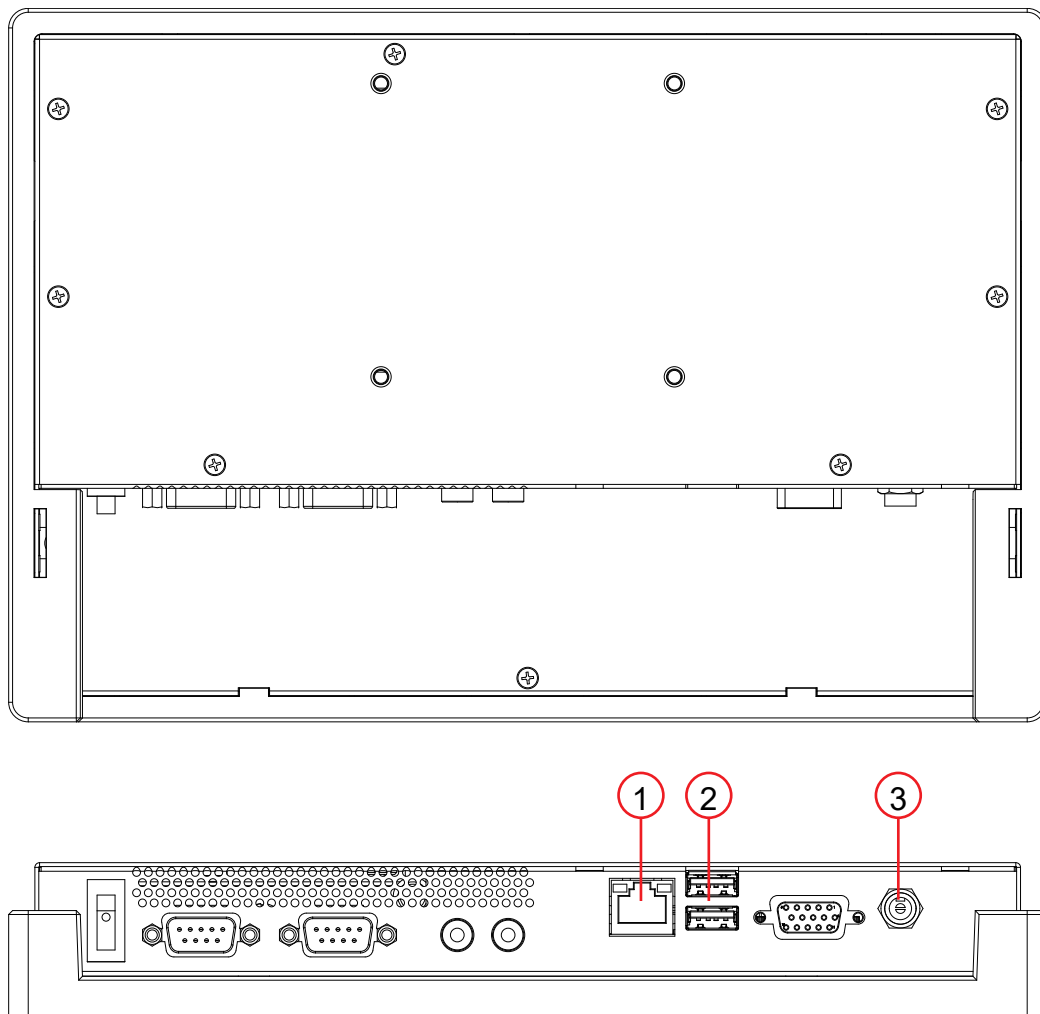

**Table 2.4** GSX-E1 Auxiliary Box Cable Interface Points

Connection Point	Description	Cable Required/Notes
J2	Main Supply Voltage Input	Auxiliary Box to Power Supply
J3	24 VDC Power Supply Out	24 V Power Supply Cable
J70	Servo Control	Servo-Control Cable
J73	Servo Power Out	Servo-Power Cable

## 2.2.4 HMI

**Figure 2.6** HMI Interface Points



**Table 2.5** Touchscreen Connections

Item	Description
1	LAN Port
2	USB 2.0/USB 3.0 Ports
3	DC Input

### NOTICE



USB ports on the HMI are for keyboards and mice only. Do not use any other kind of device into these ports.

---

## **Chapter 3: Start Switch & E-Stop**

---

**3.1 Start Switch and E-Stop Connections .....26**

## 3.1 Start Switch and E-Stop Connections

The system requires two start switches and one emergency stop connection. The start switches and E-Stop switches need to be electrically isolated from each other to complete their circuit closure. Solid state switches may be used if the leakage current is less than 0.1mA. The start switches must be closed within 200 milliseconds of each other and must remain closed until the PB Release signal is logic high.

**Figure 3.1** Start and E-Stop I/O Pin Numbers and Equivalent Circuit

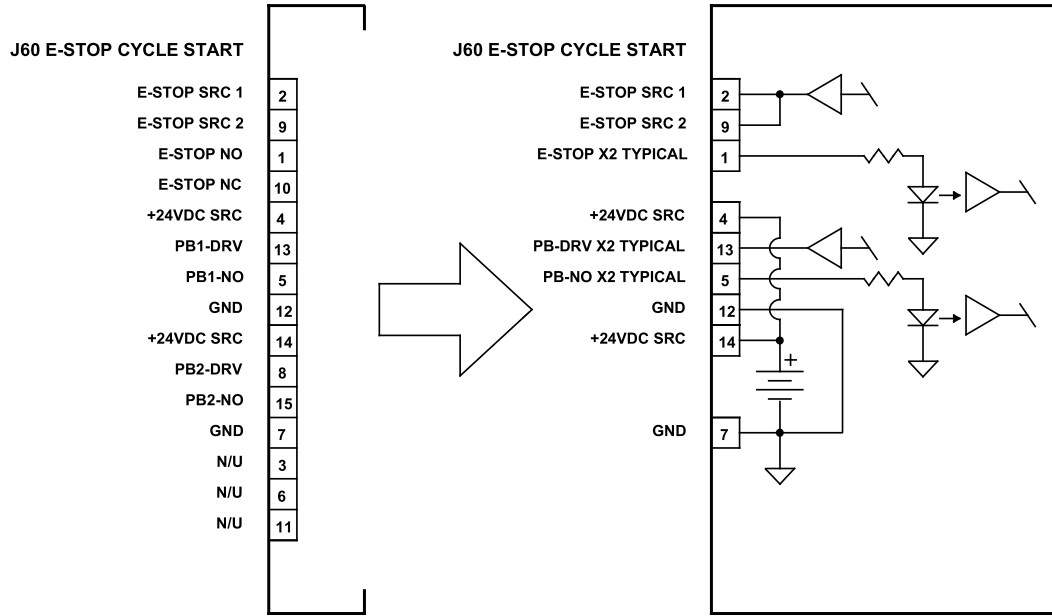

**Figure 3.2** Example of external start and emergency stop switch connections using remote start cable

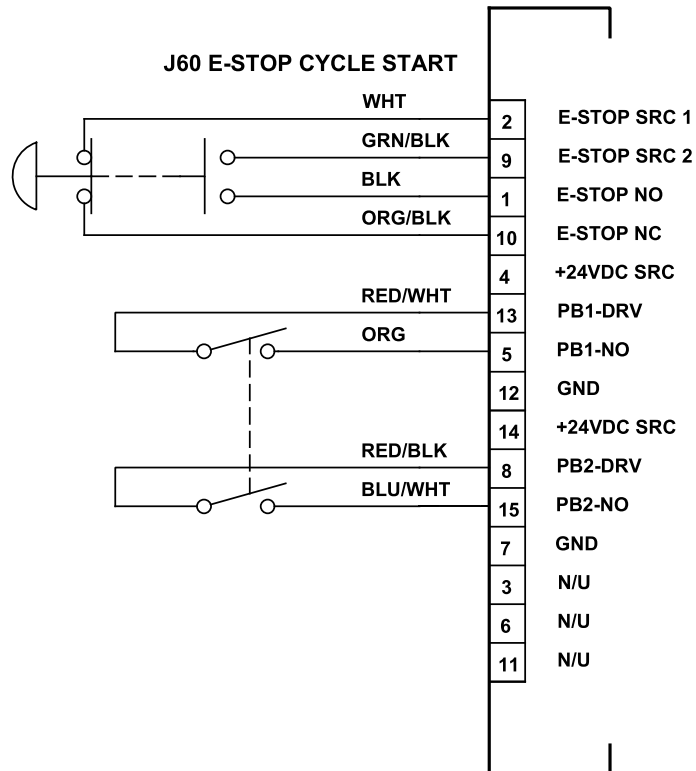

### 3.1.1 Specifications

**Table 3.1** E-Stop Specifications

Description	Value
Outputs	2 Source: SRC1 & SRC2
Output Voltage	24 VDC
Inputs	2 Sink: E-Stop NO & E-Stop NC
Input Impedance	2 k $\Omega$
Input Current	12 mA
Protection	N/A
Ext. Switch Type	1 NO & 1 NC Isolated
Ext. Switch Contact	Dry Contact

**Table 3.2** PB Start Switch Specifications

Description	Value
Outputs	2 Source: PB1-DRV & PB2-DRV
Output Voltage	24 VDC
Inputs	2 Sink: PB1-NO & PB2-NO
Input Impedance	2 k $\Omega$
Input Current	12 mA
Protection	N/A
Ext. Switch Type	2 N.O. Isolated DPST
Ext. Switch Contact	Dry Contact

**Table 3.3** +24 VDC Source

Description	Value
Number of Output Pins	2
Maximum Current	2 A (1 A/pin)
Protection	Internal Fuse
Common Points	Ground Pins - 2

[This page intentionally left blank]

---

## **Chapter 4: Mounting & Dimensions**

---

<b>4.1</b>	<b>Enclosure Mounting Considerations . . . . .</b>	<b>30</b>
<b>4.2</b>	<b>Column. . . . .</b>	<b>32</b>
<b>4.3</b>	<b>Actuator. . . . .</b>	<b>34</b>
<b>4.4</b>	<b>Power Supply. . . . .</b>	<b>36</b>
<b>4.5</b>	<b>Auxiliary Box . . . . .</b>	<b>39</b>
<b>4.6</b>	<b>HMI Monitor. . . . .</b>	<b>42</b>

## 4.1 Enclosure Mounting Considerations

Depending on the weld cycle rate and total weld power used, the ultrasonic Power Supply and Auxiliary Box can generate a large amount of internal heat.

Cooling and heat management need to be considered when selecting and designing an enclosure to house the Power Supply and Auxiliary Box. Select an enclosure that is specifically designed for electrical control equipment. The enclosure should be sized and laid out to allow adequate air flow and heat dissipation. Enclosure fans for ventilation or air conditioning may be necessary depending on the application and the number of GSX-E1 components installed in a single enclosure. The internal temperature of the enclosure should not exceed 40°C.

**Figure 4.1** Air flow paths and clearances needed

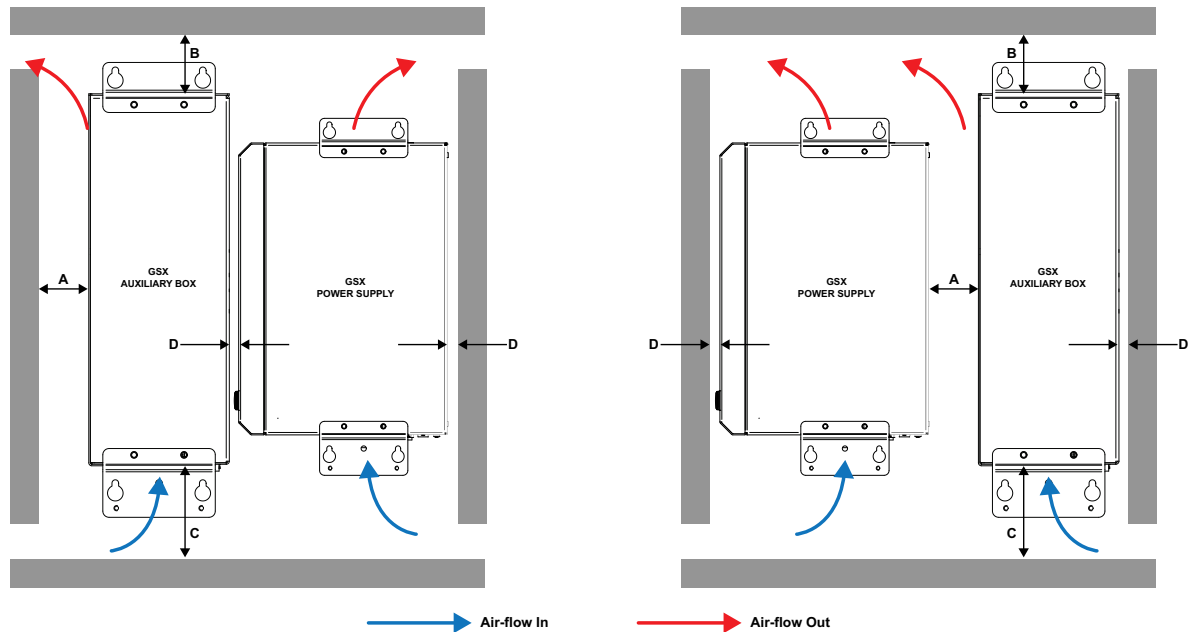

**Table 4.1**

Reference	Min. Distance
A	76 mm (3 in)
B	50 mm (2 in)
C	127 mm (5 in)
D	13 mm (0.5 in)

## Heat loss generated by the Auxiliary Box and Power Supply

Dynamic Loss - For the Power Supply, it is the internal heat generated in Watts during the ultrasonic on phase of a cycle. For the Auxiliary Box, the Dynamic Loss is the internal heat generated by the servo amplifier during the weld and hold phases of a cycle

Static Loss - The quiescent power loss in Watts due to the normal operation of the system controller and other related circuits. This value is about 10W for the Power Supply and 20W for the Auxiliary Box

Total Loss - The Total Loss is the sum of the Dynamic and Static Losses

### Formula for estimating the Dynamic Loss generated by the Power Supply

$$\text{Dynamic Loss (W)} = (1.85 \cdot 10^{-6}) \cdot (PP) \cdot (U/S \text{ Time}) \cdot (CR)$$

PP (W) = Peak Power. The power meter display in Watts after a weld cycle. This is the peak power of a weld%

U/S Time (mS) = Ultrasonic on time. The time in milliseconds that the ultrasonics are on

CR (Cycles/Min) = Cycle rate. The expected cycles per minute rate during normal operation

### Formula for estimating the Dynamic Loss generated by the Auxiliary Box

$$\text{Dynamic Loss (W)} = (8.33 \cdot 10^{-4}) \cdot (\text{Hold Time} + U/S \text{ Time}) \cdot (CR)$$

U/S Time (mS) = Ultrasonic on time. The time in milliseconds that the ultrasonics are on

Hold Time (mS) = Hold time. The time in milliseconds during a cycle that the actuator is in the hold state

CR (Cycles/Min) = Cycle rate. The expected cycles per minute rate during normal operation

### Example of heat loss calculation for the Power Supply

**Table 4.2** Information on the GSX-E1 model and measured and expected weld characteristics

Maximum Power Rated (Watts)	2500
Ultrasonic On Time (milliseconds)	100
Hold Time (milliseconds)	200
Cycle Rate (Cycle/Minute)	60
Peak Power (W)	1250

$$\text{Dynamic Loss} = 1.85 \cdot 10^{-6} \cdot (1250) \cdot (100) \cdot (60) = 14W$$

Static Loss = 10W

Total Loss = 14W + 10W = 24W

The total heat generated by the Power Supply is 24W

### Example of heat loss calculation for the Auxiliary Box

$$\text{Dynamic Loss} = 8.33 \cdot 10^{-4} \cdot (100 + 200) \cdot (60) = 15W$$

Static Loss = 20W

Total Loss = 15W + 20W = 35W

The total heat generated by the Auxiliary Box is 35W

## 4.2 Column

Remove the M4 screws from the front cover and backplate and remove them. Mount the column to a work surface using the four M12x1.75 bolts inside. Reinstall the front cover and backplate.

NOTICE	
	Torque bolts to 135 N·m (100 f-lb) in an X pattern.

Figure 4.2

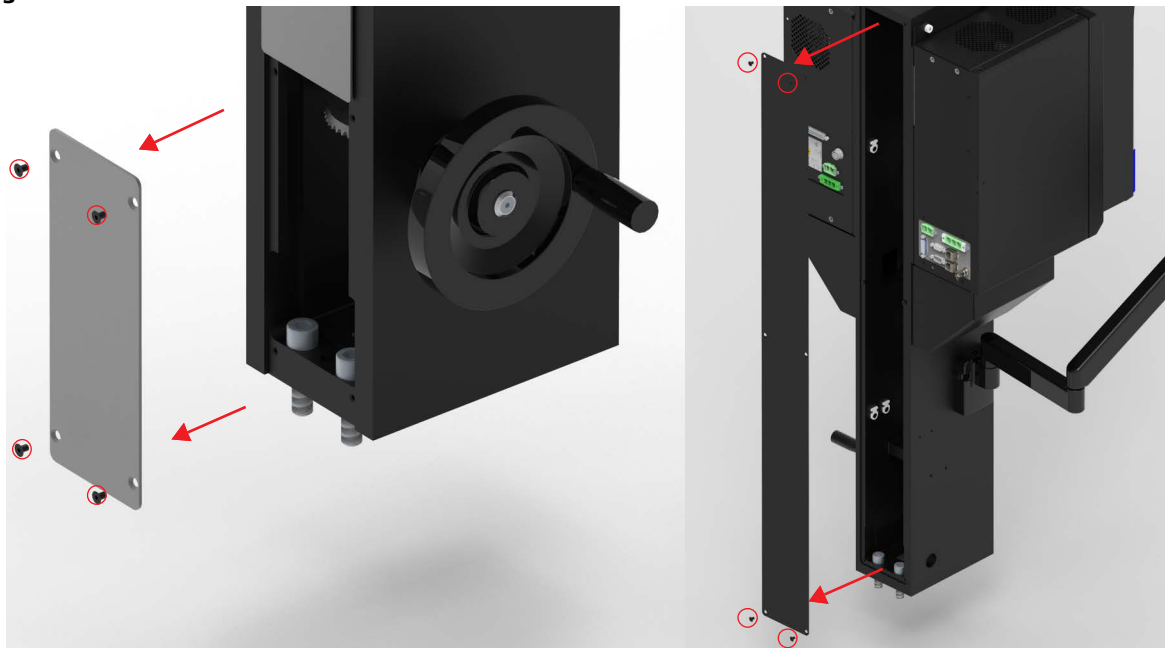

Figure 4.3

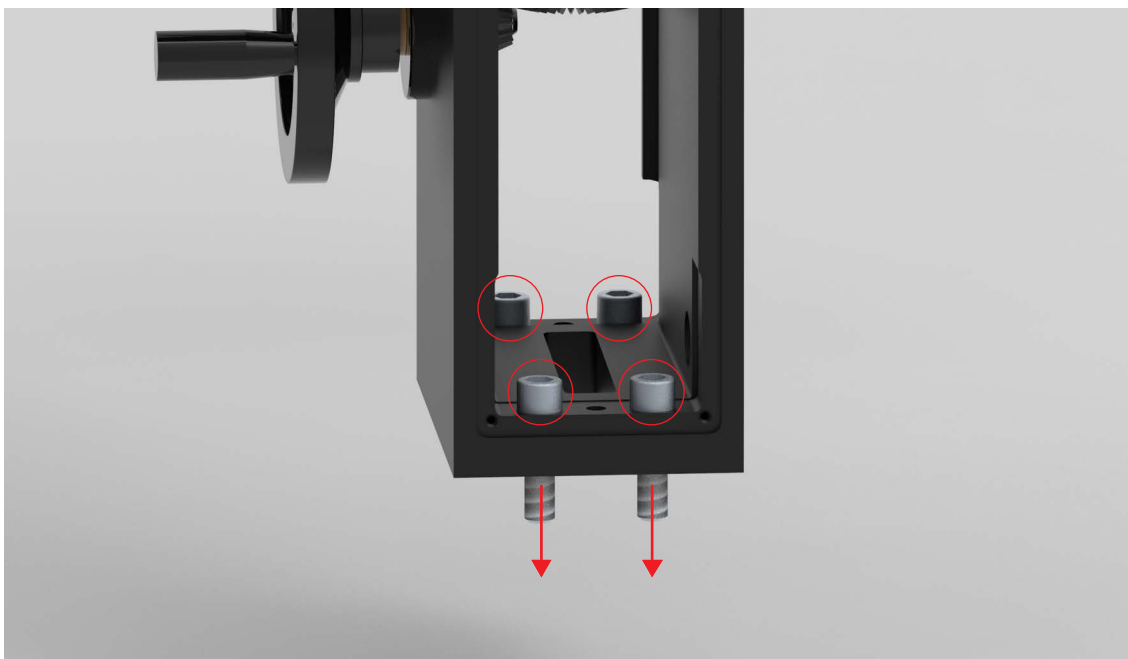
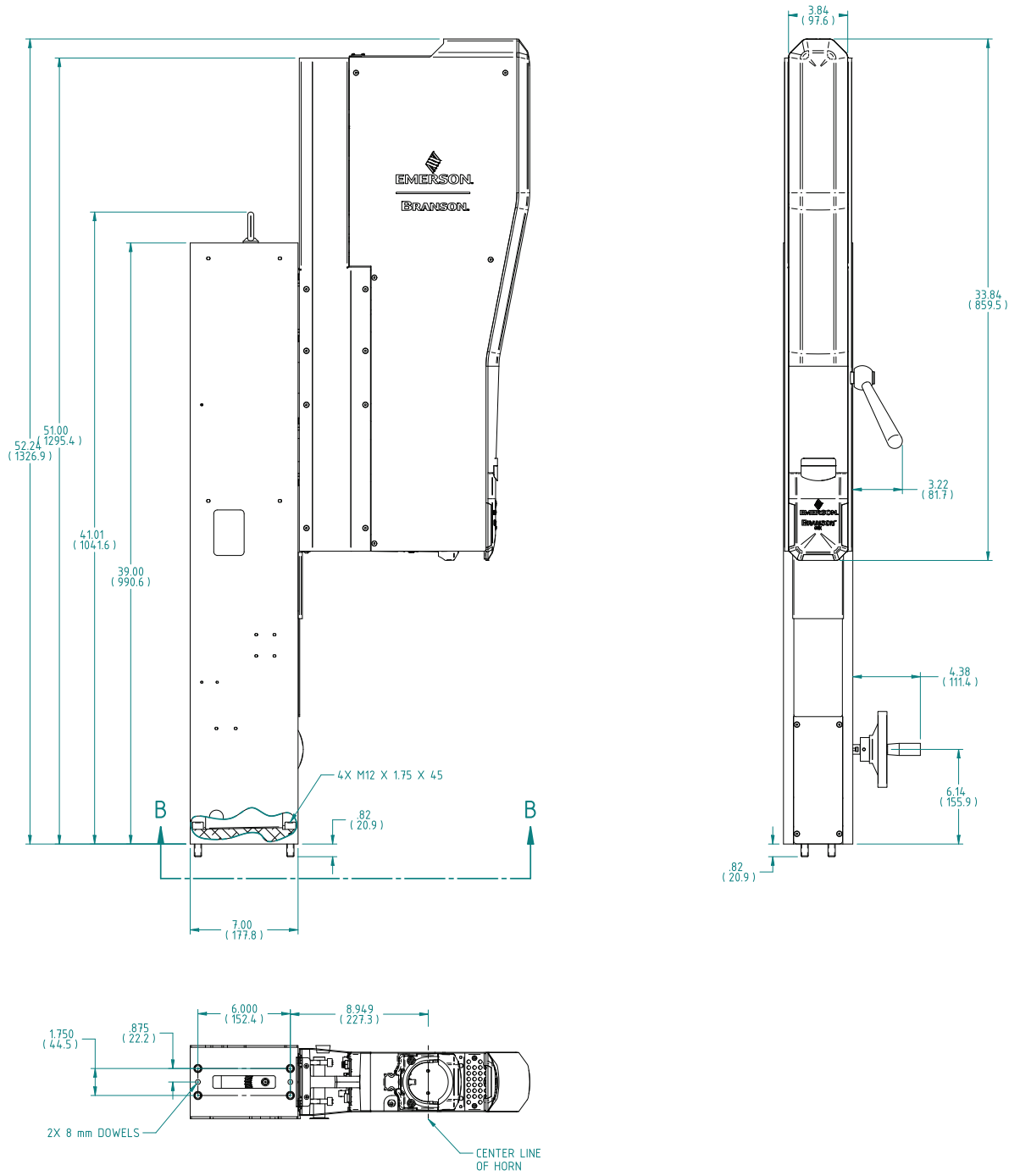

Figure 4.4



## 4.3 Actuator

Mount the actuator to an I-Beam or other rigid structure using four M10x1.5 bolts. Use dowel pins to aid with insertion and alignment (customer provided hardware).

NOTICE	
	Mounting bolts must not extend more than 10 mm into the actuator

Figure 4.5

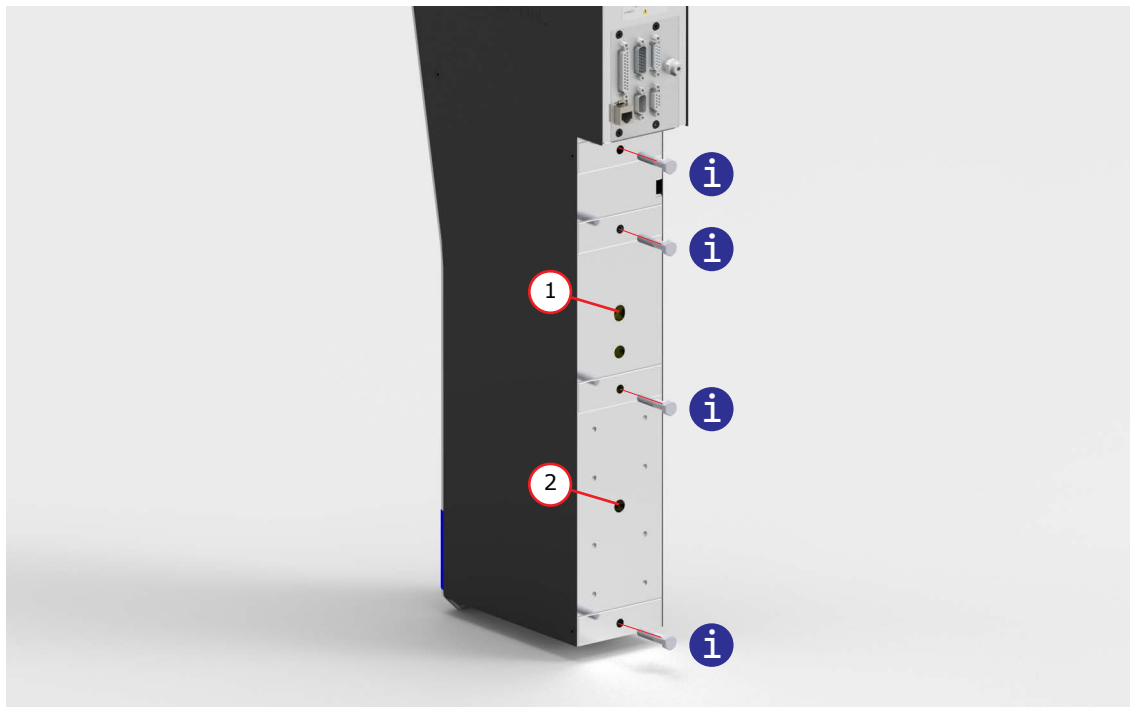
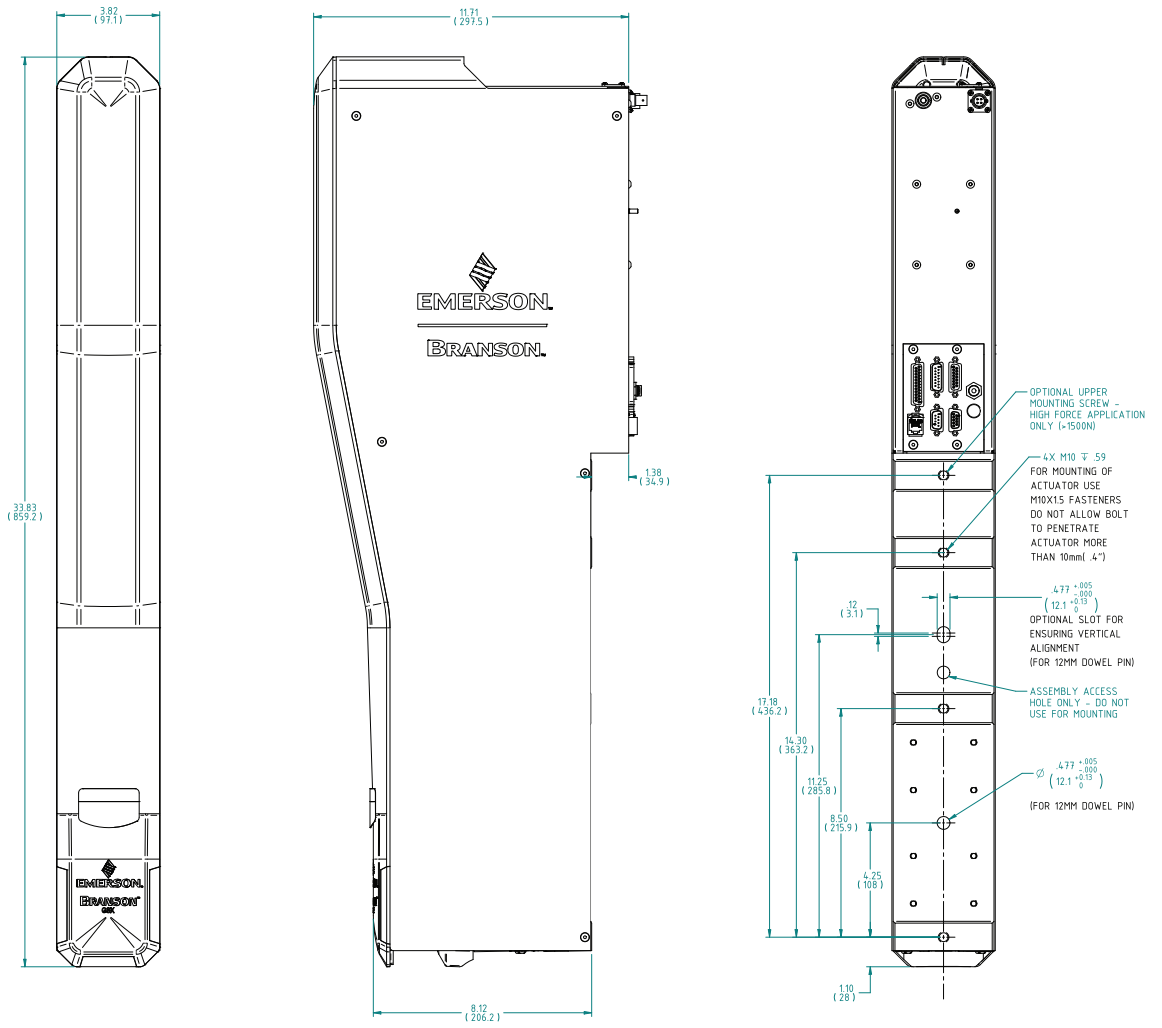

Table 4.3

Item	Description
1	Slot for 12 mm Dowel Pin
2	Hole for 12 mm Dowel Pin

Figure 4.6



## 4.4 Power Supply

### 4.4.1 Rear Mounting

Attach the mounting brackets to the power supply using four M6 bolts and washers.

Figure 4.7



Mount the power supply to an electrical cabinet using four M6 bolts, with flat washers against its metal plate (customer provided hardware).

Figure 4.8



#### 4.4.2 Side Mounting

Attach the mounting brackets to the power supply using four M6 bolts and washers.

Figure 4.9



Mount the power supply to an electrical cabinet using four M6 bolts, with flat washers against its metal plate (customer provided hardware).

Figure 4.10



Figure 4.11

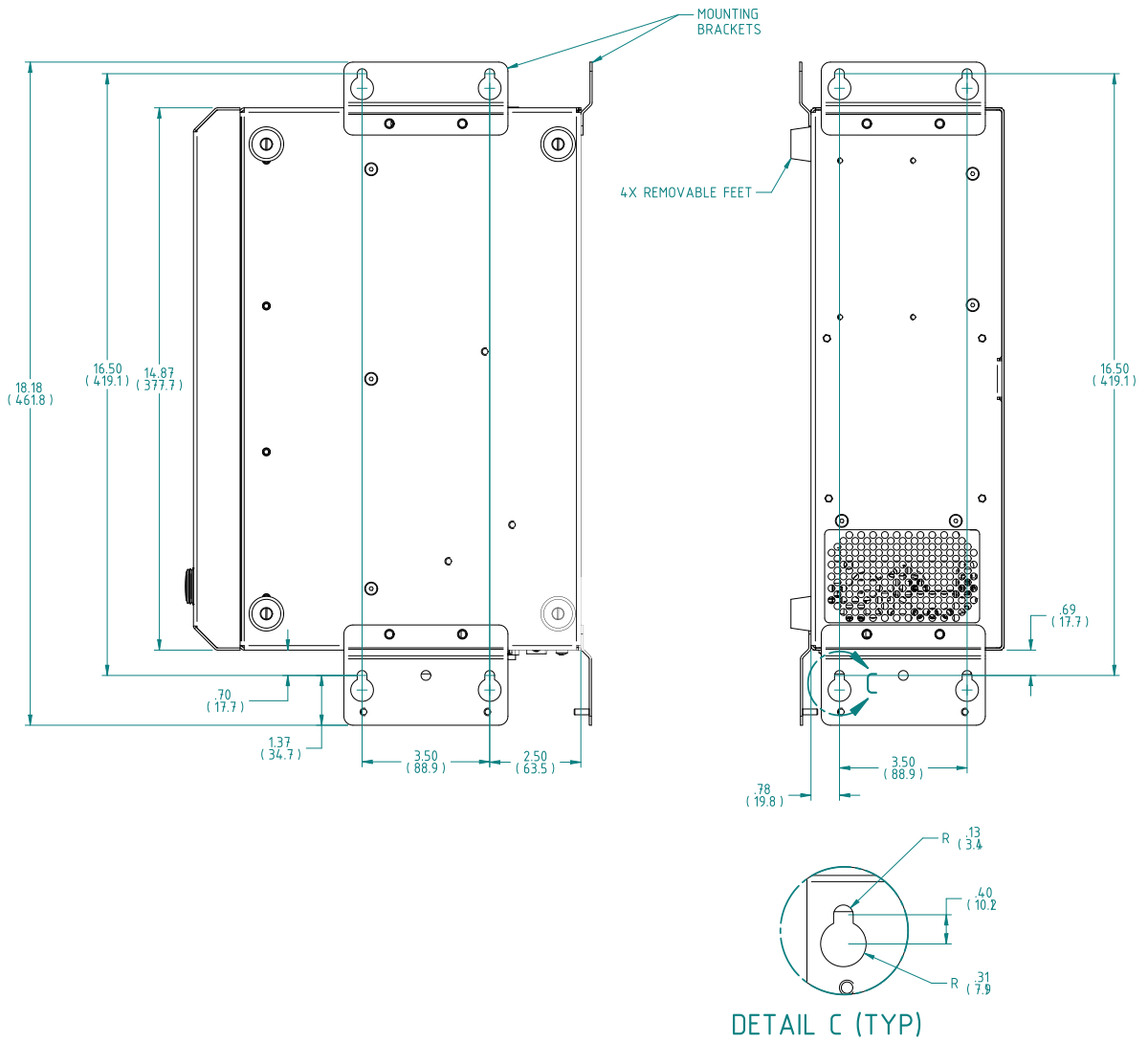

## 4.5 Auxiliary Box

### 4.5.1 Rear Mounting

Attach the mounting bracket to the auxiliary box using four M6 bolts and washers.

Figure 4.12

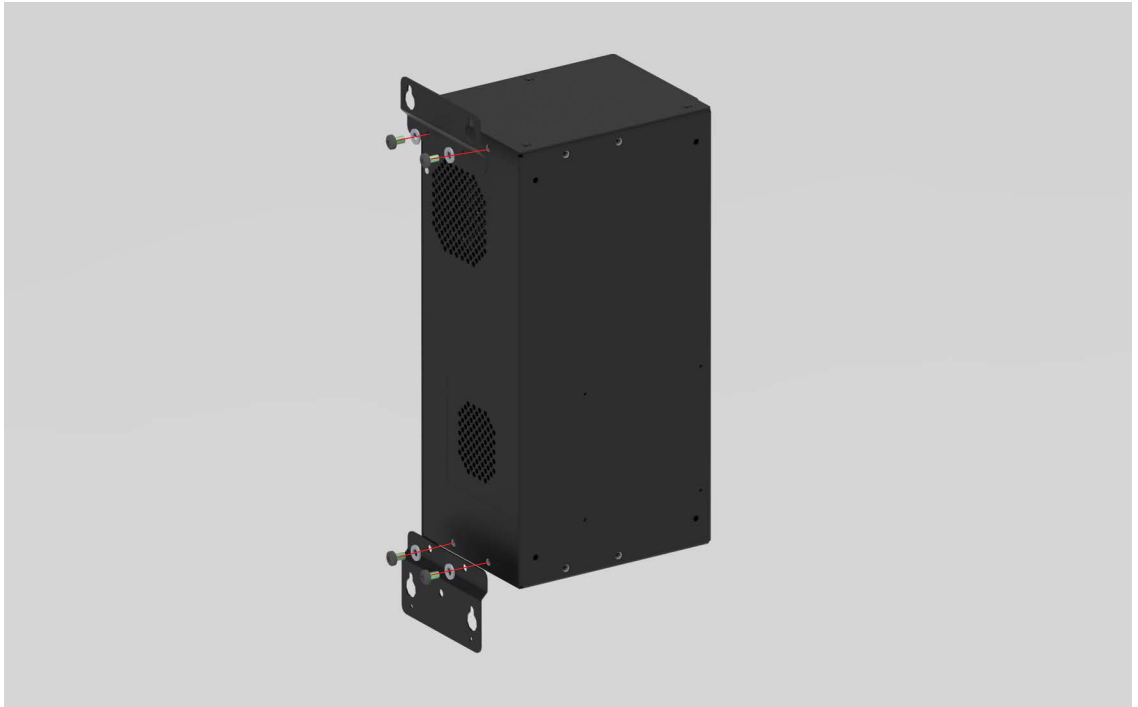

Mount the auxiliary to an electrical cabinet using four M6 bolts, with flat washers against its metal plate (customer provided hardware).

Figure 4.13

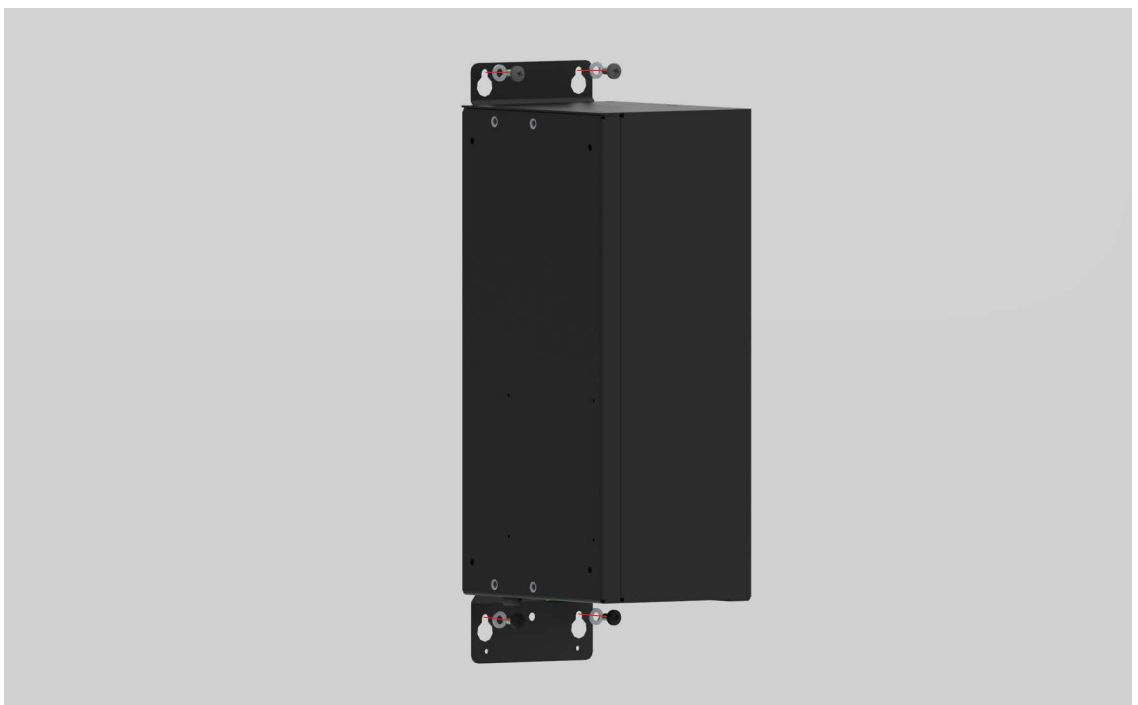

## 4.5.2 Side Mounting

Attach the mounting bracket to the auxiliary box using four M6 bolts and washers.

Figure 4.14



Mount the auxiliary to an electrical cabinet using four M6 bolts, with flat washers against its metal plate (customer provided hardware).

Figure 4.15

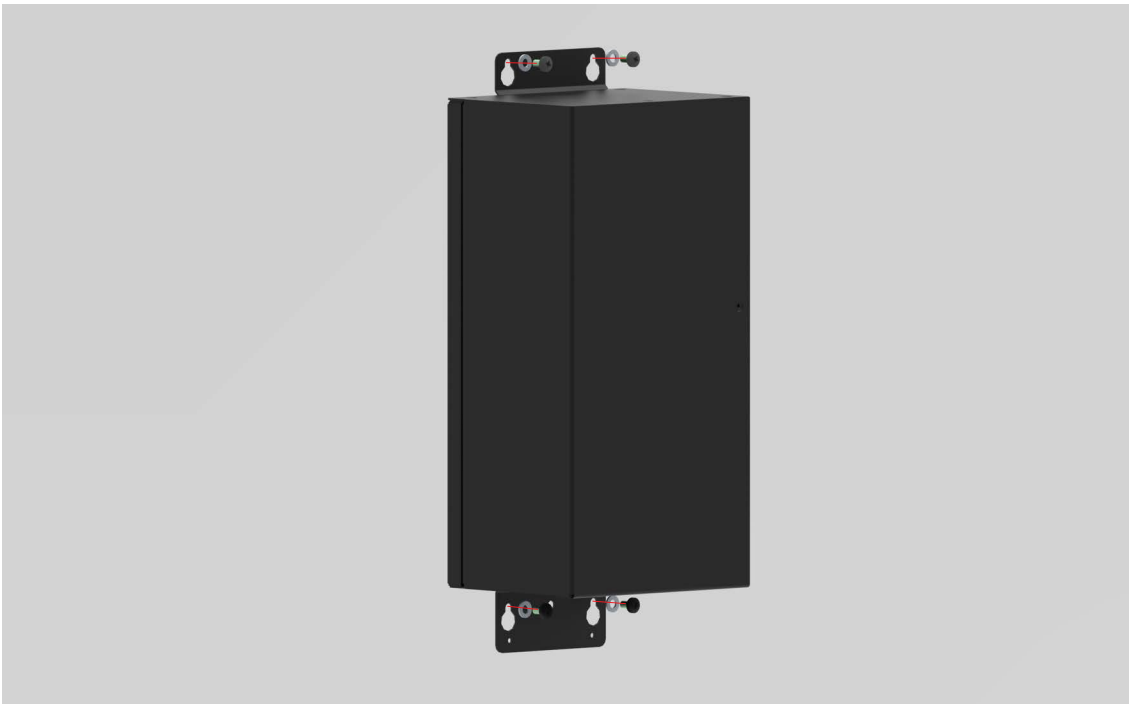
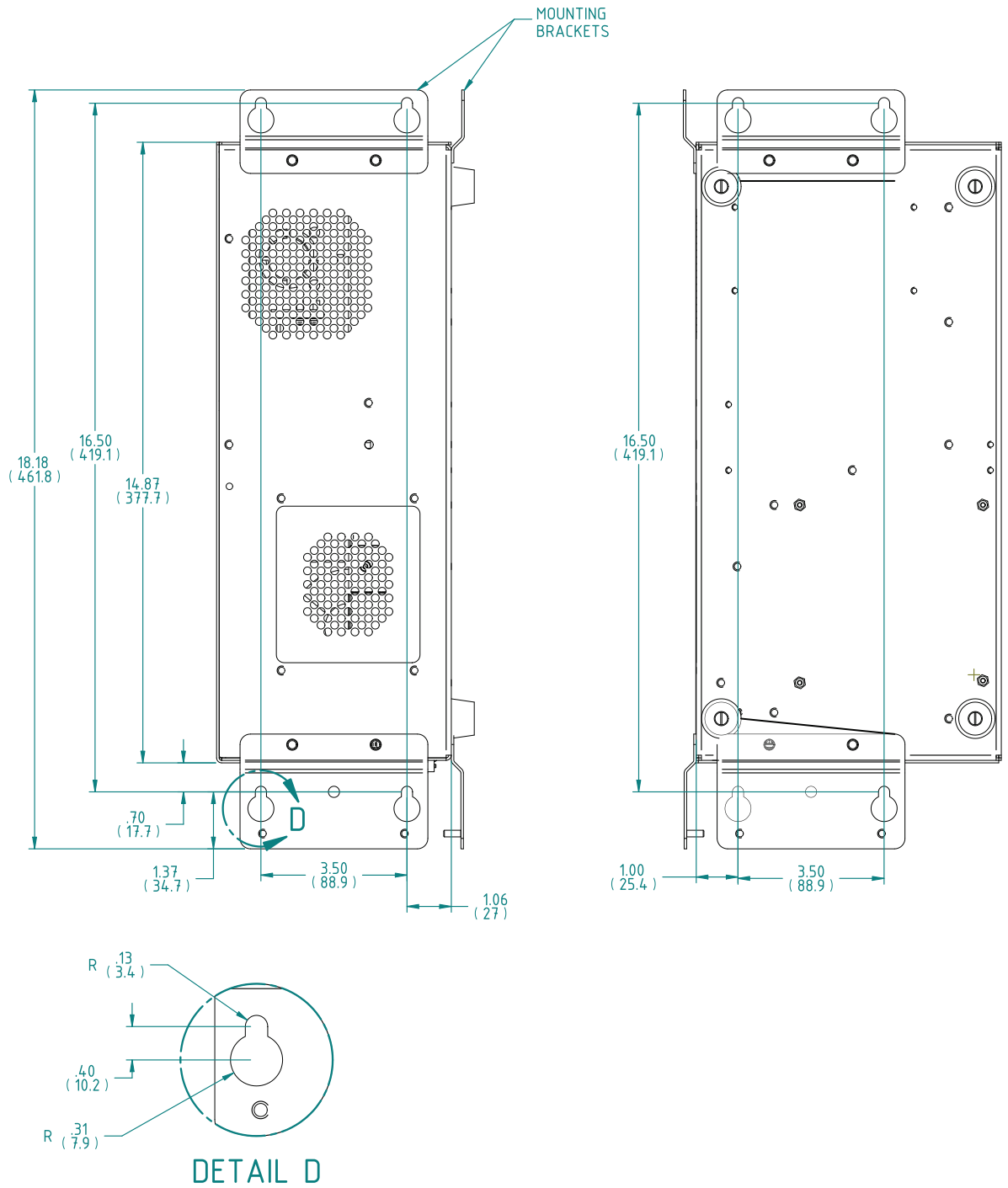

Figure 4.16



## 4.6 HMI Monitor

### 4.6.1 VESA Mounting

To install the monitor to a flat surface, attach a VESA 75 mounting bracket to the back of the monitor using four M4x10mm screws (customer provided hardware).

Figure 4.17 HMI Monitor Dimensions

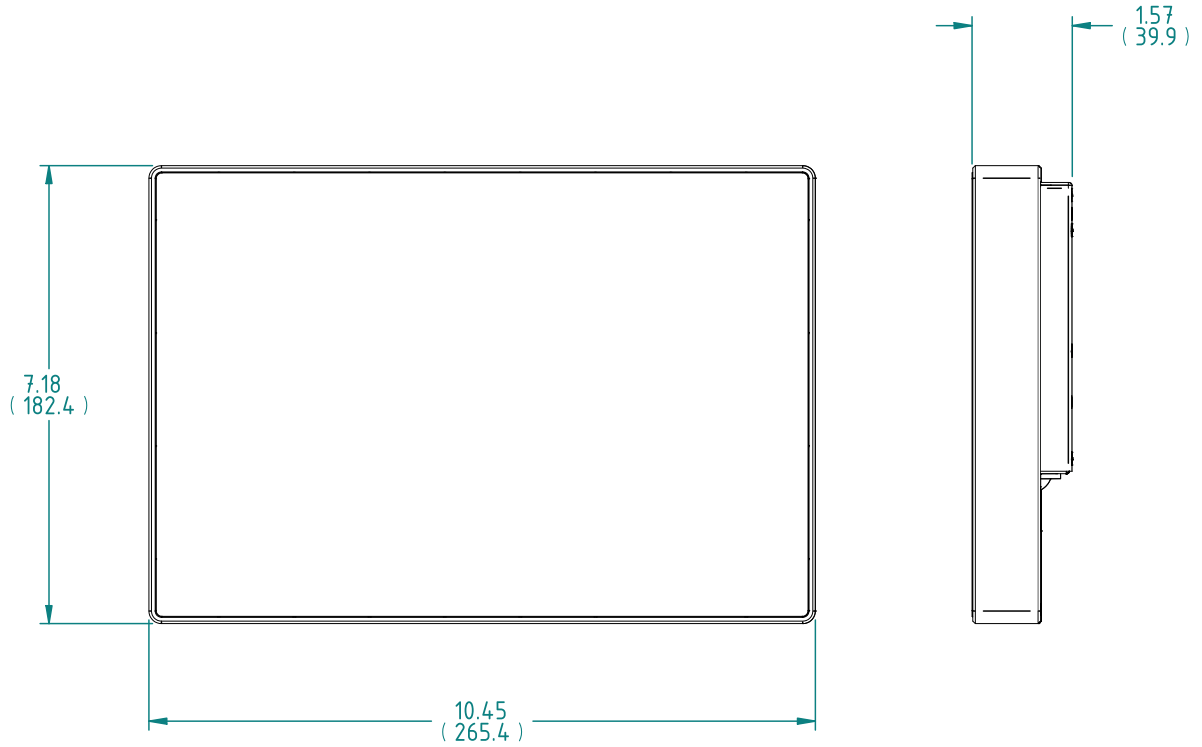
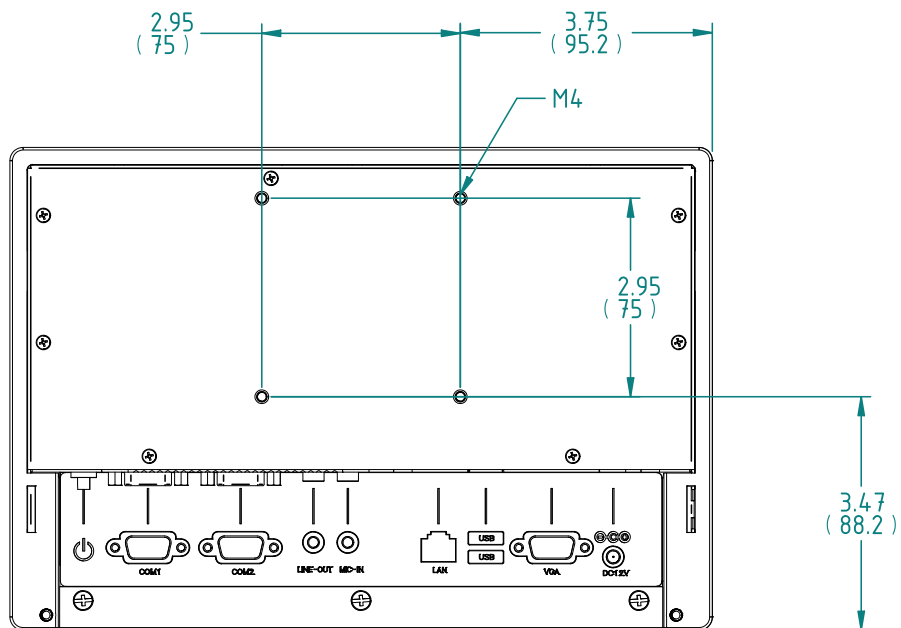
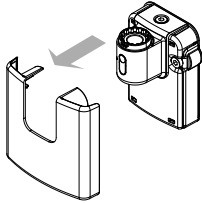
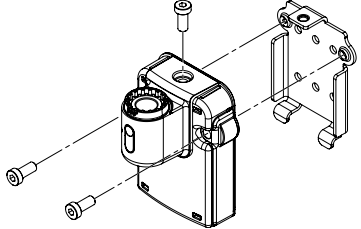
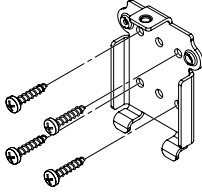
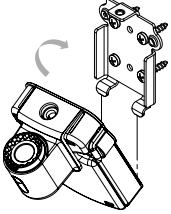
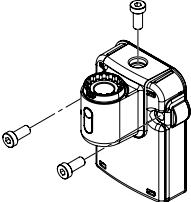
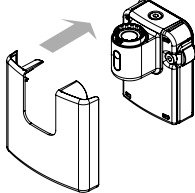
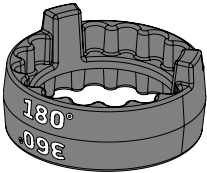
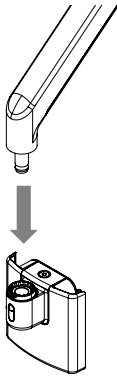

Figure 4.18 VESA 75 Mounting Holes



## 4.6.2 Monitor Arm (optional)

**Table 4.4** Monitor Arm

Step	Instructions	Step	Instructions
1	<p>Remove the plastic front cover.</p> 	2	<p>Remove the two side screws and top screw from the mount and separate the mounting plate from the rest of the mount.</p> 
3	<p>Attach the mounting plate to a wall stud or other structural support using the screws provided. Mounting to drywall alone is not recommended. Use level to ensure that mounting plate is perfectly level.</p> 	4	<p>Align the mount with the mounting plate on the wall.</p> 
5	<p>Reinstall the two side screws and top screw into the mount and tighten.</p> 	6	<p>Reinstall the plastic cover.</p> 
7	<p>Position the stop ring to limit the arm's range of motion if desired. The marked angle will be in the center of the range of motion.</p> 	8	<p>Insert monitor arm into the mount until release button locks in place. To remove arm press release button and pull the arm up near the joint.</p> 

**Figure 4.19** Dimensions - Monitor Arm

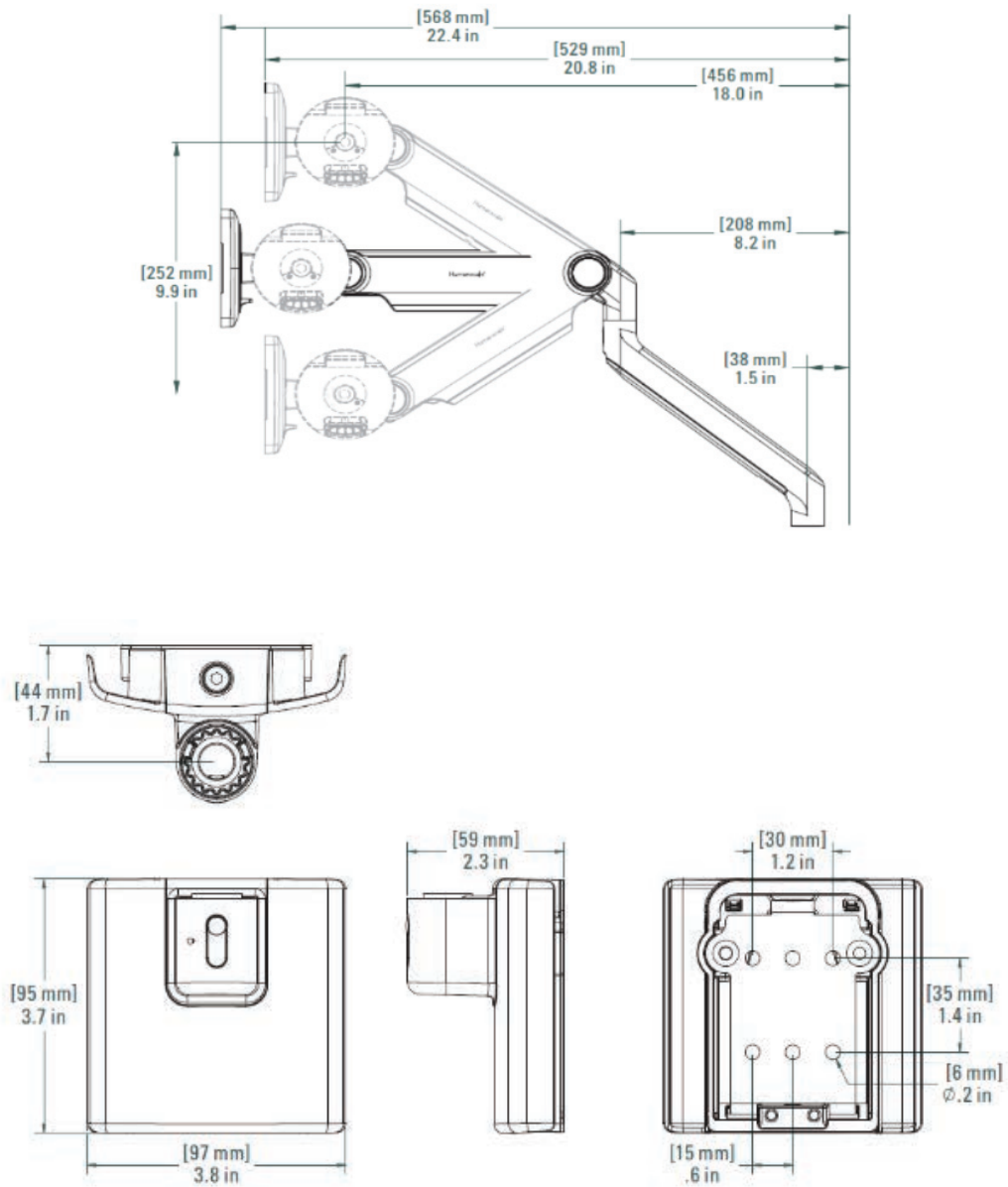

### 4.6.2.1 Attaching Touchscreen to Arm

**Table 4.5** Attaching Touchscreen to Arm

Step	Action
1	Tilt the monitor back and lower onto the arm, so that the hook fits into the corresponding hole on the VESA bracket. Then rotate the bottom of the monitor back towards the arm until the tab snaps in place.
2	To remove, lift the release tab and pull the bottom of the monitor away from the arm, then lift free of the hook.

**Figure 4.20** Attaching Touchscreen to Arm

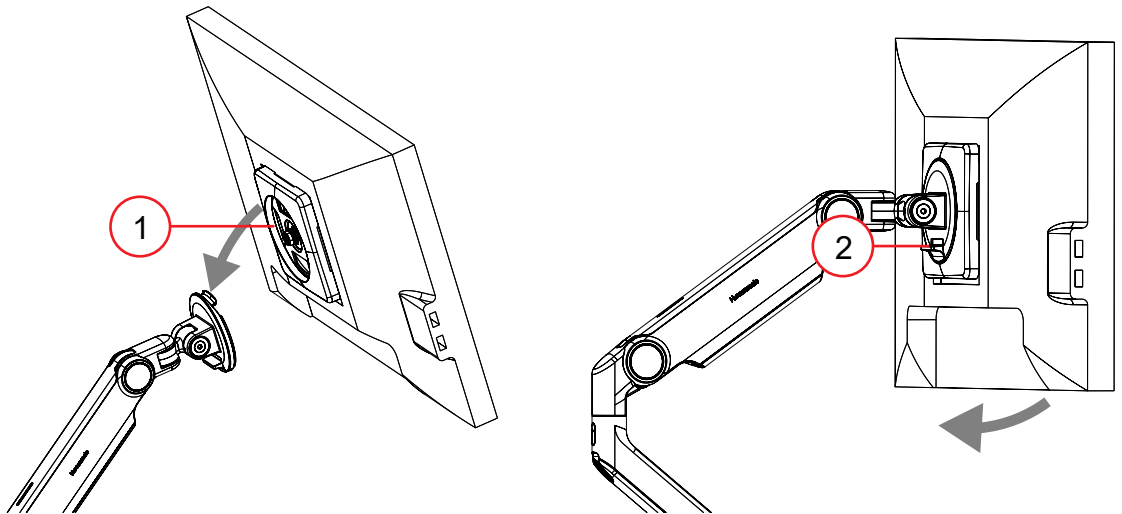

**Table 4.6** Arm

Item	Description
1	VESA bracket
2	Release tab

[This page intentionally left blank]

[This page intentionally left blank]



**Branson Ultrasonics Corporation**

120 Park Ridge Road  
Brookfield, CT 06804  
(203) 796-0400

<http://www.bransonultrasonics.com>

Copyright © 2025 Branson Ultrasonics Corporation. All rights reserved. Contents of this publication may not be reproduced in any form without the written permission of Branson Ultrasonics Corporation.

**BRANSON**