

GSX-E1

Ultrasonic Welder

V2 Model

User Manual

Branson Ultrasonics Corporation
120 Park Ridge Road
Brookfield, CT 06804
(203) 796-0400
<http://www.bransonultrasonics.com>

BRANSON

[This page intentionally left blank]

Manual Change Information

At Branson, we strive to maintain our position as the leader in ultrasonics plastics joining, metal welding, cleaning and related technologies by continually improving our products. These improvements are incorporated as soon as they are developed and thoroughly tested.

Information concerning any improvements will be added to the appropriate technical documentation at its next revision. Therefore, when requesting service assistance for specific units, note the revision information found on this document.

Copyright and Trademark Notice

Copyright © 2025 Branson Ultrasonics Corporation. All rights reserved. Contents of this publication may not be reproduced in any form without the written permission of Branson Ultrasonics Corporation.

[This page intentionally left blank]

Table of Contents

Chapter 1: Safety

1.1	Safety Information	16
1.2	General Precautions	22
1.3	Declaration of Conformity	24
1.4	UK Declaration of Conformity	25

Chapter 2: Introduction

2.1	Branson GSX-E1 Welding System	28
2.2	Principle of Operation	29
2.3	System Components	30
2.4	Glossary of Terms	34

Chapter 3: Technical Specifications

3.1	Technical Specifications	46
3.2	Physical Description	49

Chapter 4: Installation and Setup

4.1	About Installation	56
4.2	Installation Requirements	57
4.3	Installation Steps	58
4.4	HMI Touchscreen Monitor	60
4.5	Interface Points	63
4.6	Input Power Connection	66
4.7	User I/O	69
4.8	Ground Detect Cable	73
4.9	Safety Equipment	74
4.10	Acoustic Stack	75
4.11	Installing the Ultrasonic Stack in the Actuator	87
4.12	Mounting the Fixture on the Base	89
4.13	Adjusting Welder Height and Aligning the Horn	90
4.14	Converter Cooling	92
4.15	LED Lamp	94
4.16	USB Accessories	95
4.17	Barcode Scanner	96
4.18	Password Recovery Kit	98

Chapter 5: Operation

5.1	GSX-E1 System Power On and Login	100
5.2	Screen Layout	102
5.3	Date & Time	103
5.4	Setting Up An Application	104
5.5	Main Menu & Action Center	107
5.6	Dashboard	109
5.7	Recipes	113
5.8	Production	127
5.9	Analytics	128
5.10	System	130
5.11	Actuator Setup	159
5.12	Scan/Seek/Test	161

5.13	Optional Dynamic Weld Mode	164
Chapter 6: Maintenance		
6.1	General Maintenance Considerations	166
6.2	Periodically Clean the Equipment	167
6.3	Electromechanical Actuator Assembly Maintenance	168
6.4	Recondition the Stack (Converter, Booster and Horn)	172
6.5	GSX-E1 Systems, Accessories, Spare Parts & Options	174
Chapter 7: Support		
7.1	Warranty	182
7.2	How to Contact Branson	183
Appendix A: Alarms		
A.1	Alarm Categories	188
Appendix B: Timing Diagrams		
B.1	State Timing Diagrams	200
B.2	Output Timing Diagrams	201
B.3	I/O Timing Diagrams	202
B.4	Home & Ready Position Timing Diagrams	205
Appendix C: System Automation		
C.1	GSX-E1 Automation Guide	208
C.2	GSX-E1 EtherNet/IP Automation Guide	209
Appendix D: Web Services		
D.1	Overview	212
D.2	Enable Web Service Communication	213
D.3	Authentication Key	214
D.4	Command List	216
D.5	HTTPS Support	234
Appendix E: EtherNet/IP		
E.1	GSX-E1 EtherNet/IP	238
Appendix F: Frequently Asked Questions		
F.1	Frequently Asked Questions	240

List of Figures

Chapter 1: Safety

Figure 1.1	Labels on the back of the system	17
Figure 1.2	System Information Label	18
Figure 1.3	Labels on the back of the actuator	19
Figure 1.4	Labels on the front of the actuator	20
Figure 1.5	Labels on the base	21
Figure 1.6	Declaration of Conformity	24
Figure 1.7	UK Declaration of Conformity.	25

Chapter 2: Introduction

Figure 2.1	GSX-E1 System	28
Figure 2.2	How does ultrasonic welding work?	29
Figure 2.3	Power Supply.	30
Figure 2.4	Auxiliary Box	31
Figure 2.5	Touchscreen HMI	31
Figure 2.6	Start Switches	32
Figure 2.7	Elevation Hand Crank	32
Figure 2.8	LED Lamp	33
Figure 2.9	Emergency Stop.	33

Chapter 3: Technical Specifications

Figure 3.1	Front Side	50
Figure 3.2	Left Side	51
Figure 3.3	Right Side	52
Figure 3.4	Back Side	53
Figure 3.5	Base	54

Chapter 4: Installation and Setup

Figure 4.1	Base mounting centers	59
Figure 4.2	Attaching Touchscreen to Arm	60
Figure 4.3	Arm Adjustments	61
Figure 4.4	HMI Interface Points	62
Figure 4.5	GSX-E1 Actuator Cable Interface Points	63
Figure 4.6	GSX-E1 Power Supply Cable Interface Points	64
Figure 4.7	GSX-E1 Auxiliary Box Cable Interface Points	65
Figure 4.8	International Harmonized Line Cord Color Code	68
Figure 4.9	Power Supply User I/O Cable Identification and Wire Color Diagram.	69
Figure 4.10	User I/O Cable Identification and Wire Color Diagram.	70
Figure 4.11	Ground Detect Cable	73
Figure 4.12	Emergency Stop Button	74
Figure 4.13	Torque Wrench Kit	75
Figure 4.14	Assembling the Acoustic Stack.	80
Figure 4.15	Sleeve Assembly	81
Figure 4.16	20 kHz Universal Stack Vise, EDP 100-063-642	82
Figure 4.17	Connecting Tip to Horn	85
Figure 4.18	Installing the ultrasonic stack in the actuator.	87
Figure 4.19	Quick ultrasonic stack change	88
Figure 4.20	Mounting Holes on Base	89
Figure 4.21	Air Inlet	92

Figure 4.22 LED Lamp	94
Figure 4.23 USB Ports	95
Figure 4.24 Barcode scanner, 1D linear barcode & 2D barcode example	96
Figure 4.25 Power Supply - USB port on the GSX-E1 system	96
Figure 4.26 Power Supply - USB port on the GSX-E1 EtherNet/IP system	97
Figure 4.27 Password Recovery Kit (EDP 1016041)	98

Chapter 5: Operation

Figure 5.1 Power button on the GSX-E1 system	100
Figure 5.2 Power button on the GSX-E1 EtherNet/IP system	100
Figure 5.3 Screen Layout	102
Figure 5.4 Main Menu	107
Figure 5.5 Action Center	108
Figure 5.6 Dashboard Screen	109
Figure 5.7 Active Recipe Actions Menu	110
Figure 5.8 Weld Results Actions Menu	111
Figure 5.9 Alarm Log Actions Menu	112
Figure 5.10 Recipes Screen	113
Figure 5.11 Active Recipe Actions Menu	114
Figure 5.12 New Recipe	115
Figure 5.13 Pretrigger	117
Figure 5.14 Afterburst	118
Figure 5.15 Parameters A-Z	119
Figure 5.16 Limits - Setup	121
Figure 5.17 Limits - Control	122
Figure 5.18 Limits - Suspect & Reject	123
Figure 5.19 Stack Recipe	124
Figure 5.20 Production Setup	125
Figure 5.21 Batch Setup	126
Figure 5.22 Production Screen	127
Figure 5.23 Analytics	128
Figure 5.24 Alarms	129
Figure 5.25 System	130
Figure 5.26 General	131
Figure 5.27 User Management	133
Figure 5.28 Add User	134
Figure 5.29 Power Supply I/O	135
Figure 5.30 Actuator I/O	137
Figure 5.31 User Authority	139
Figure 5.32 Global User Settings	140
Figure 5.33 Change Password	141
Figure 5.34 Alarm Management	142
Figure 5.35 Tooling	143
Figure 5.36 USB port on the GSX-E1 system	146
Figure 5.37 USB port on the GSX-E1 EtherNet/IP system	146
Figure 5.38 Security	149
Figure 5.39 Ethernet Port	149
Figure 5.40 EtherNet/IP Settings	150
Figure 5.41 Machine Details	151
Figure 5.42 Event Log	158
Figure 5.43 Event Log - More Info	158
Figure 5.44 Actuator Setup	159
Figure 5.45 Advanced Feature	160
Figure 5.46 Scan	161
Figure 5.47 Seek	162
Figure 5.48 Ultrasonic Test	163
Figure 5.49 Dynamic Weld Mode	164

Chapter 6: Maintenance

Figure 6.1	Nozzle	169
Figure 6.2	Grease Gun	169
Figure 6.3	Grease	169
Figure 6.4	Roller Screw	170

Chapter 7: Support**Appendix A: Alarms**

Figure A.1	Alarm	188
------------	-------	-----

Appendix B: Timing Diagrams

Figure B.1	Weld Cycle With No Alarms	200
Figure B.2	PBRelease, U/S On and Cycle Running Outputs	201
Figure B.3	Part Present Input & Ready Output	202
Figure B.4	U/S Disable & Reset Input	202
Figure B.5	Cycle Abort Input	203
Figure B.6	Reject Output	203
Figure B.7	Hold Delay Input	204
Figure B.8	Actuator Starts in Ready Position	205
Figure B.9	Actuator Starts in Home Position	206

Appendix C: System Automation**Appendix D: Web Services**

Figure D.1	Ethernet Port	212
Figure D.2	Web Service Communication Toggle	213
Figure D.3	Weld Results ID	229

Appendix E: EtherNet/IP**Appendix F: Frequently Asked Questions**

Figure F.1	Power button on the GSX-E1 system	240
Figure F.2	Power button on the GSX-E1 EtherNet/IP system	240
Figure F.3	Machine Details	241
Figure F.4	Screen Layout	244
Figure F.5	Alarm	245
Figure F.6	USB Ports	246
Figure F.7	Barcode scanner, 1D linear barcode & 2D barcode example	247
Figure F.8	Power Supply - USB port on the GSX-E1 system	247
Figure F.9	Power Supply - USB port on the GSX-E1 EtherNet/IP system	248

[This page intentionally left blank]

List of Tables

Chapter 1: Safety

Table 1.1	Labels on the back of the system	17
Table 1.2	System Information Label	18
Table 1.3	Labels on the back of the actuator	19
Table 1.4	Labels on the front of the actuator	20
Table 1.5	Labels on the base	21

Chapter 2: Introduction

Table 2.1	Glossary of Terms	34
-----------	-----------------------------	----

Chapter 3: Technical Specifications

Table 3.1	Environmental Specifications	46
Table 3.2	Input Current	47
Table 3.3	Continuous Duty Maximum Power - Power Supply	47
Table 3.4	Force vs Time Recommendations	48
Table 3.5	Dimensions and Weights of GSX-E1 System	49

Chapter 4: Installation and Setup

Table 4.1	Lift Point Location.	57
Table 4.2	Mounting the Stand	59
Table 4.3	Location of base mounting centers	59
Table 4.4	Attaching Touchscreen to Arm	60
Table 4.5	Arm	60
Table 4.6	Arm Adjustments	61
Table 4.7	Arm Screws	61
Table 4.8	Touchscreen Connections	62
Table 4.9	GSX-E1 Actuator Cable Interface Points	63
Table 4.10	GSX-E1 Power Supply Cable Interface Points	64
Table 4.11	GSX-E1 Auxiliary Box Cable Interface Points	65
Table 4.12	Line Cord Color Code	68
Table 4.13	User I/O Cable	69
Table 4.14	User I/O Cable	70
Table 4.15	Default Power Supply I/O Configurations	71
Table 4.16	Actuator User I/O Cable Pin Assignments	72
Table 4.17	Ground Detect Cable	73
Table 4.18	Emergency Stop Button	74
Table 4.19	Torque Wrench Kit #1	76
Table 4.20	Torque Wrench Kit #2	76
Table 4.21	Miscellaneous	77
Table 4.22	Assembly Instructions For a 20 kHz System	78
Table 4.23	Assembly Instructions For a 30 kHz System	78
Table 4.24	Assembly Instructions For a 40 kHz System	79
Table 4.25	Assembling the Acoustic Stack	80
Table 4.26	Sleeve assembly	81
Table 4.27	Mounting the Stand	83
Table 4.28	Torque values	84
Table 4.29	Studs for Boosters	84
Table 4.30	Mounting the Stand	85
Table 4.31	Tip to Horn Torque Specification	85

Table 4.32	Stud Washers - 20 kHz	85
Table 4.33	Stud Washers - 40 kHz	86
Table 4.34	Step Studs for Horns*	86
Table 4.35	Installing the ultrasonic stack in the actuator	87
Table 4.36	Screws	87
Table 4.37	Quick ultrasonic stack change.	88
Table 4.38	Screws	88
Table 4.39	Adjusting Welder Height and Aligning the Horn.	90
Table 4.40	Air Inlet.	92
Table 4.41	Continuous Duty Maximum Power - Power Supply.	93
Table 4.42	Converter Cooling Procedure	93
Table 4.43	LED Lamp Location	94
Table 4.44	USB Ports	95
Table 4.45	Power Supply - USB port on the GSX-E1 system.	96
Table 4.46	Power Supply - USB port on the GSX-E1 EtherNet/IP system	97
Table 4.47	Password Recovery Kit Instructions.	98

Chapter 5: Operation

Table 5.1	Date & Time	103
Table 5.2	Setting up an application	104
Table 5.3	Parameters A-Z	117
Table 5.4	Parameters A-Z	118
Table 5.5	Parameters A-Z	119
Table 5.6	Stack Recipe	124
Table 5.7	Configuration Options	131
Table 5.8	GSX-E1 Power Supply I/O Descriptions - Inputs	136
Table 5.9	GSX-E1 Power Supply I/O Descriptions - Outputs	136
Table 5.10	GSX-E1 Actuator I/O Descriptions - Inputs.	137
Table 5.11	GSX-E1 Actuator I/O Descriptions - Outputs.	137
Table 5.12	Operators Authority Options.	138
Table 5.13	Generate Report	146
Table 5.14		149
Table 5.15	Software Upgrade Instructions	152

Chapter 6: Maintenance

Table 6.1	Roller Screw	170
Table 6.2	Greasing Procedure	171
Table 6.3	Stack Reconditioning Procedure	172
Table 6.4	Stack Torque Values	173
Table 6.5	GSX-E1 Systems - V2 Model.	174
Table 6.6	GSX-E1 EtherNet/IP Systems	174
Table 6.7	GSX-E1 Systems - V1 Model.	174
Table 6.8	Converters	175
Table 6.9	Boosters - 20 kHz	175
Table 6.10	Boosters - 30 kHz	176
Table 6.11	Boosters - 40 kHz	176
Table 6.12	Spare Parts - GSX-E1 - V2 & EtherNet/IP Models	177
Table 6.13	Spare Parts - GSX-E1 - V1 Model	179
Table 6.14	GSX-E1 System Options	180

Chapter 7: Support

Table 7.1	Authorized Service Center (Americas)	183
Table 7.2	Authorized Service Centers (Europe)	184
Table 7.3	Authorized Service Centers (Asia/Pacific)	185

Appendix A: Alarms

Table A.1	No Cycle	189
-----------	----------	-----

Table A.2	Hardware Failure	190
Table A.3	Cycle Modified	192
Table A.4	Suspect.	193
Table A.5	Reject.	194
Table A.6	Warnings.	195
Table A.7	Weld Overloads	196
Table A.8	Energy Brake Overloads	196
Table A.9	Afterburst Overloads.	196
Table A.10	Post-Weld Seek Overloads.	196
Table A.11	Test Overloads.	197
Table A.12	Pretrigger Overloads.	197
Table A.13	Seek Overloads	197
Table A.14	Pre-Weld Seek Overloads	197
Table A.15	EN Faults	198

Appendix B:Timing Diagrams

Appendix C:System Automation

Appendix D:Web Services

Table D.1	Authentication Key	214
Table D.2	Command List	216
Table D.3	Recipe Parameter ID.	220
Table D.4	Weld Mode	224
Table D.5	Mode Value	224
Table D.6	Amplitude Step At	224
Table D.7	Amplitude Step Value (1-10)	224
Table D.8	Force Step At.	225
Table D.9	Force Step Value (1-10)	225
Table D.10	Parameter ID and Values	226
Table D.11	Weld Mode	230
Table D.12	Recipe Status	230
Table D.13	Parameter ID.	232
Table D.14	Server Error Responses.	234

Appendix E:EtherNet/IP

Appendix F:Frequently Asked Questions

Table F.1	USB Ports	246
Table F.2	Power Supply - USB port on the GSX-E1 system	247
Table F.3	Power Supply - USB port on the GSX-E1 EtherNet/IP system.	248





[This page intentionally left blank]

Chapter 1: Safety

1.1	Safety Information	16
1.2	General Precautions	22
1.3	Declaration of Conformity	24
1.4	UK Declaration of Conformity	25

1.1 Safety Information

Observe the following safety information in these operating instructions; this information will warn you about risks and their consequences.

DANGER	Indicates an immediate danger
	If these risks are not avoided, death or severe injury will be the result.
WARNING	Indicates a possible danger
	If these risks are not avoided, death or severe injury might result.
CAUTION	Indicates a possible danger
	If these risks are not avoided, slight or minor injury might result.
NOTICE	Indicates a possible damaging situation
	If this situation is not avoided, the system or something in its vicinity might be damaged. Application types and other important or useful information are emphasized.

1.1.1 GSX-E1 System Labeling

NOTICE	
	<p>Only Branson service personnel or Branson trained representatives are allowed to open, maintain and service the system.</p> <p>Unauthorized tampering with, modifying, or opening the unit will void the warranty.</p>

Figure 1.1 Labels on the back of the system



Table 1.1 Labels on the back of the system



Label	Description
	<p>High Voltage Hazard</p> <p>Hazardous voltage inside will cause death or severe injury. De-energize system before removing covers. Authorized personnel only.</p>
	<p>Caution</p> <p>Improper connection can cause a short and damage the unit.</p>

Figure 1.2 System Information Label

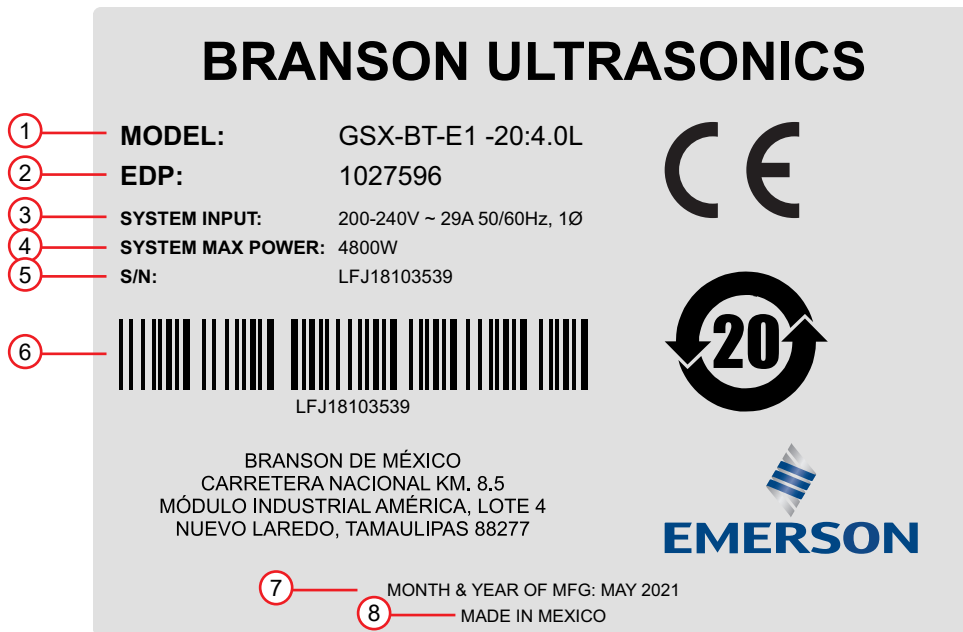

Table 1.2 System Information Label

Item	Description	Item	Description
1	System model	5	Serial number
2	EDP number	6	Barcode
3	System input	7	Month & year of manufacture
4	System maximum power	8	Assembly location

Figure 1.3 Labels on the back of the actuator



Table 1.3 Labels on the back of the actuator

Label	Description
	<p>PE Protective earth.</p>

Figure 1.4 Labels on the front of the actuator

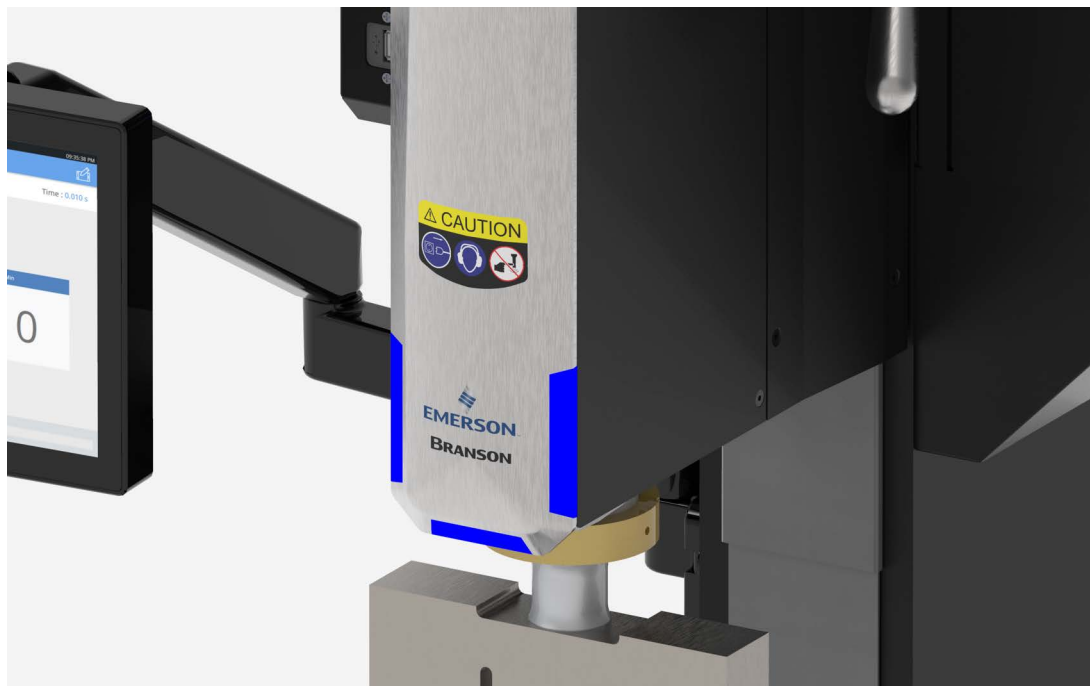

Table 1.4 Labels on the front of the actuator







Label	Description
	<p>Caution</p> <ul style="list-style-type: none"> • High Voltage Hazard • Loud Noise Hazard • Burn Hazard
	<p>Disconnect power before servicing.</p>
	<p>Ear protection must be worn.</p>
	<p>Do not touch the tooling.</p>

Figure 1.5 Labels on the base

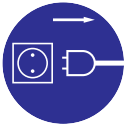



Table 1.5 Labels on the base

Label	Description
	<p>Crush Hazard Moving parts present. Can result in serious injury to hands or fingers. Keep hands away from moving horn.</p>
	<p>Emergency Stop Button In case of emergency, push button to stop cycle.</p>
	<p>Burn Hazard Do not touch the tooling.</p>

1.2 General Precautions

Ensure that the GSX-E1 system installation is performed by qualified personnel and in accordance with local standards and regulation.

DANGER	
	<p>Power supply and auxiliary box produce high voltage. Before working on the power supply and auxiliary box assembly, do the following:</p> <ul style="list-style-type: none"> • Turn off the power supply and auxiliary box and unplug both line cords • Allow at least 5 minutes for capacitors to discharge

DANGER	
	<p>To prevent the possibility of an electrical shock, always plug the power supply and auxiliary box into a grounded power source.</p>



DANGER	
	<p>High voltage is present in the system. Do not operate with covers removed.</p>

DANGER	
	<p>High voltage exist in the ultrasonic power supply and auxiliary box assembly. Use only non-grounded, battery-powered multi-meters when testing the power supply and auxiliary box assembly. Using other types of test equipment can present a shock hazard</p>

CAUTION	
	<p>Keep hands from under the horn. Down force (pressure) and ultrasonic vibrations can cause injury</p>

CAUTION	
	<p>Do not cycle the welding system if either the RF cable or converter is disconnected.</p>

CAUTION	
	<p>Do not cycle the welding system without front cover in place.</p>

CAUTION	
	When using larger horns, avoid situations where fingers could be pinched between the horn and the fixture.
CAUTION	
	<p>Sound level and frequency of the noise emitted during the ultrasonic assembly process may depend upon a. type of application, b. size, shape and composition of the material being assembled, c. shape and material of the holding fixture, d. welder setup parameters and e. tool design.</p> <p>Some parts vibrate at an audible frequency during the process. Some or all of these factors may result in an uncomfortable noise being emitted during the process.</p> <p>In such cases operators may need to be provided with personal protective equipment. See 29 CFR (Code of Federal Regulations) 1910.95 Occupational Noise Exposure.</p>

1.2.1 Emissions

Because of the various types of toxic or injurious gases that may be liberated during the welding based on the material being processed, sufficient ventilation should be provided to prevent a concentration of these gases in excess of 0.1 ppm. Check with your materials suppliers for recommended protection when processing their materials.

CAUTION	
	Processing of many materials, such as PVC, can be hazardous to an operator's health and could cause corrosion/damage to the equipment. Use proper ventilation and take protective measures.

1.2.2 Intended Use of the System

The GSX-E1 components are designed to be used as part of an ultrasonic welding system. These are designed for a wide variety of welding or processing applications.

If the equipment is used in a manner not specified by Branson, the protection provided by the equipment may be impaired.

Branson Ultrasonics Corporation designs and manufactures machines giving the first priority to safety precautions, to allow customers to use the machines safely and effectively. Only trained personnel should operate or service the equipment. Untrained operators can misuse the equipment or ignore safety instructions that can result in personal injury or equipment damage. It is essential that all operators and service personnel pay attention to safety instructions when operating and servicing the equipment.

1.2.3 Setting up the Workplace

Measures for setting up a workplace for safe operation of the ultrasonic welder are outlined in [Chapter 4: Installation and Setup](#).

1.2.4 Regulatory Compliance

This product meets electrical safety requirements and EMC (Electromagnetic Compliance) requirements for North America and the European Union.

1.3 Declaration of Conformity

Figure 1.6 Declaration of Conformity

DocuSign Envelope ID: A374A0B1-EF34-4924-A34A-E45EB05B8C4A

EC DECLARATION OF CONFORMITY
According to the Machinery Directive 2006/42/EC.



We, the manufacturer

BRANSON ULTRASONICS CORPORATION
120 Park Ridge Road.
Brookfield, CT 06804
USA

represented in the community by

BRANSON ULTRASONICS, a.s.
Piestanska 1202
915 01 Nove Mesto nad Vahom
Slovak Republic

expressly declare under our sole responsibility that the equipment Ultrasonic Welding System:

Model: GSX-BT-E1 (20:1.25, 20:2.5, 20:4.0, 30:1.5 or 40:0.8)
GSX-E1 EIP (20:1.25, 20:2.5, 20:4.0, 30:1.5 or 40:0.8) BT

Serial Number: PPPYYMMXXXXR

Where: PPP=Prefix (LHD, LHE, LHP, LHR, LHS, LFH, LFI, LFJ, LFL, LFN, LIP, LIQ, LIR, LIS, LIT, LJC, LJD, LJE,
LJF or LJG)

YY=Year, MM=Month, XXXX=Sequential Number, R=Revision (A, B, C...Z)
Manufacturing date: March 2024 or later

used with converter model: CJ20, CA30 or 4TJ, and associated cables,

in the state in which it was placed on the market, fulfills all the relevant provisions of the Machinery Directive **2006/42/EC**, the EMC Directive **2014/30/EU** and the RoHS EU directive **2011/65/EU** and their amendments. The safety objectives set out in the Low Voltage Directive **2014/35/EU** were kept in accordance Annex 1 No. 1.5.1 of the Machinery Directive **2006/42/EC**.

The object of this declaration is in conformity with relevant Union harmonization legislation. The equipment, to which this declaration relates, is in conformity with the following standards:

EN 61010-1:2010+A1:2019
EN 60204-1:2018
EN ISO 12100:2010
EN 55011:2016/A11:2020
EN 61000-6-2:2019
EN ISO 13849-1:2015
EN ISO 13849-2:2012

Person authorised to compile the technical file:

BRANSON ULTRASONICS, a.s.
Piestanska 1202
91501 Nove Mesto nad Vahom
Slovak Republic

Brookfield, CT, USA
March 26, 2024

DocuSigned by:
Luis Benavides
018235BFCD147C...

Luis Benavides
Sr. Engineering Manager / Product Safety Officer

1.4 UK Declaration of Conformity

Figure 1.7 UK Declaration of Conformity

UK DECLARATION OF CONFORMITY



We, the manufacturer

BRANSON ULTRASONICS CORPORATION
120 Park Ridge Road.
Brookfield, CT 06804
USA

expressly declare under our sole responsibility that the equipment Ultrasonic Welding System

Models: GSX-BT-E1 (20:1.25, 20:2.5, 20:4.0, 30:1.5 or 40:0.8)
GSX-E1 EIP (20:1.25, 20:2.5, 20:4.0, 30:1.5 or 40:0.8) BT

Serial Number: PPPYYMMXXXX

Where: PPP=Prefix (LHD, LHE, LHP, LHR, LHS, LFH, LFI, LFJ, LFL, LFN, LIP, LIQ, LIR, LIS, LIT, LJC, LJD, LJE, LJF or LJG)
YY=Year, MM=Month, XXXX=Sequential Number

Manufacturing date: February 2025 or later

in the state in which it was placed on the market, fulfills all the relevant provisions of:

Supply of Machinery (Safety) Regulations **2008**
Electromagnetic Compatibility Regulations **2016**
Restriction of the Use of Certain Hazardous Substances in Electrical and Electronic Equipment Regulations **2012**.

The object of this declaration is in conformity with relevant UK Statutory Instruments and their amendments. The equipment, to which this declaration relates, is in conformity with the following designated standards:

EN 61010-1:2010+A1:2019
EN 60204-1:2018
EN ISO 12100:2010
EN 55011:2016/A11:2020
EN 61000-6-2:2019
EN ISO 13849-1:2015
EN ISO 13849-2:2012

Authorised representative / person authorised to compile the technical file:

Emerson Process Management Limited, company No 00671801
Meridian East, Leicester
LE19 1UX, United Kingdom

Brookfield, CT, USA
February 07, 2025

[Luis Benavides \(Feb 8, 2025 18:43 CST\)](#)

Luis Benavides
Director of Engineering, Systems / Product Safety Officer

[This page intentionally left blank]

Chapter 2: Introduction

2.1	Branson GSX-E1 Welding System	28
2.2	Principle of Operation	29
2.3	System Components	30

2.1 Branson GSX-E1 Welding System

The Branson GSX-E1 system utilizes an advanced electro-mechanical system to provide unprecedented control and position accuracy, whilst applying the industry's lowest trigger force for precise ultrasonic welds of small, delicate components. Smart-welding technology and intuitive HMI enable easier set-up, operation and changeover to help reduce operator error and prevent potential rejects.

Figure 2.1 GSX-E1 System



The GSX-E1 welding system consists of a power supply, an actuator, auxiliary box, touchscreen and a converter-booster-horn stack. The system can perform a variety of ultrasonic welding operations, including: inserting, staking, spot welding, swaging, degating. It is designed for use in manual production systems.

The GSX-E1 system is classified as heavy industrial for compliance purposes.

2.2 Principle of Operation

Thermoplastic parts are welded ultrasonically by applying high-frequency vibrations to the parts being assembled. The vibrations, through surface and intermolecular friction, produce a sharp rise in temperature at the welding interface.

When the temperature is high enough to melt the plastic, there is a flow of material between the parts. When the vibrations stop, the material solidifies under pressure and a weld results.

Most plastics welders operate at a frequency above the range of human hearing (18 kHz) and are thus called ultrasonic.

Figure 2.2 How does ultrasonic welding work?

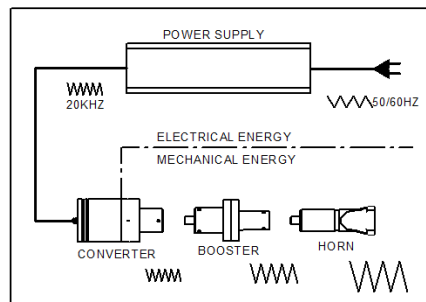

2.2.1 Benefits of ultrasonic welding

Ultrasonic welding exhibits unique welding properties that include:

- Low heat build up during the ultrasonic process (no annealing of materials)
- Compensation for normal surface variations of the material
- Ability to weld large areas using minimal energy
- Ability to weld thin materials to thick materials
- Low cost per weld

2.3 System Components

NOTICE



System components may vary depending on product model.

2.3.1 Actuator

The actuator brings the ultrasonic stack to the work piece and maintains controlled contact throughout the weld cycle.

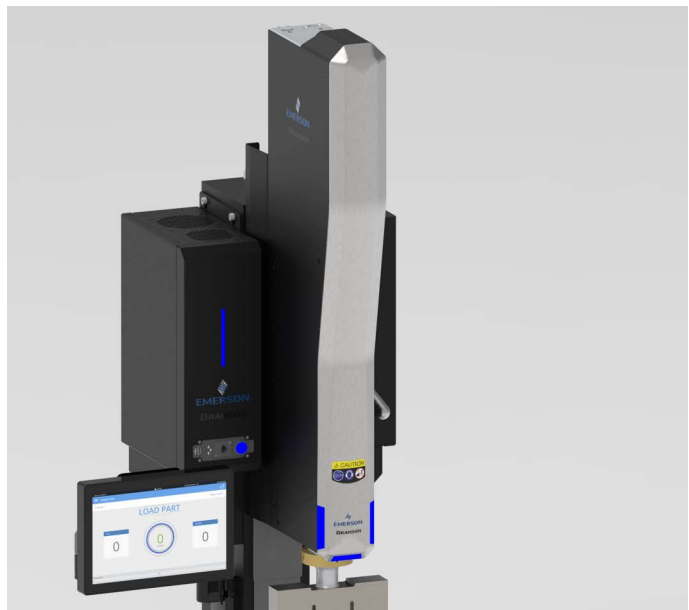

2.3.2 Power Supply

The power supply module converts conventional 50/60 Hz line current to 20 kHz, 30 kHz or 40 kHz electrical energy. The system controller monitors and controls the welding system.

Figure 2.3 Power Supply



2.3.3 Auxiliary Box

The auxiliary box houses the actuator and column motor drivers.

Figure 2.4 Auxiliary Box



2.3.4 Touchscreen HMI

The intuitive touchscreen HMI is located directly in the operator's line of sight ensuring operators always have access to critical, actionable weld data.

Figure 2.5 Touchscreen HMI



2.3.5 Palm Button Start Switches

Palm button start switches provide an ergonomically advantageous method for an operator to start a weld cycle.

Figure 2.6 Start Switches



2.3.6 Elevation Hand Crank

Elevation hand crank to adjust the height of the actuator column.

Figure 2.7 Elevation Hand Crank

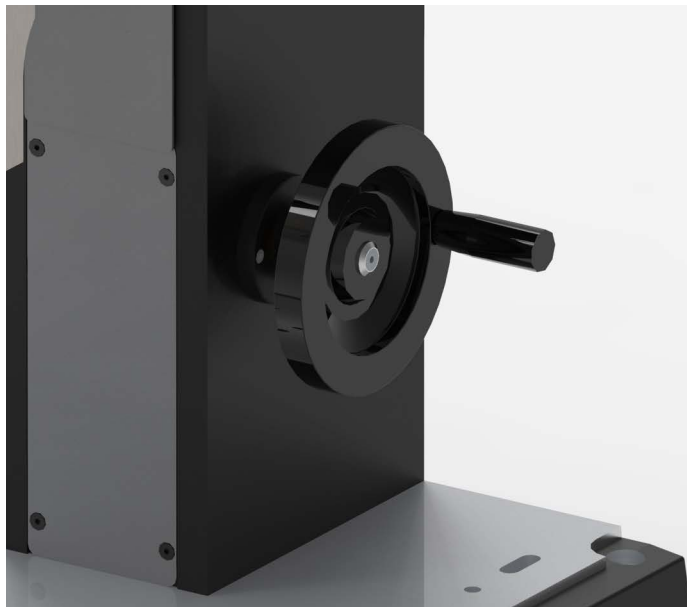

2.3.7 LED Lamp

Built-in LED lamp provides illumination with ease to work surfaces.

Figure 2.8 LED Lamp



2.3.8 Emergency Stop

Safety mechanism to de-energize the system in an emergency.

Figure 2.9 Emergency Stop



2.4 Glossary of Terms

Table 2.1 Glossary of Terms

Name	Description
AB Amplitude	The amplitude at the horn face during the afterburst step.
AB Delay	Time delay between the end of the hold and the start of the afterburst.
AB Time	The duration of the afterburst.
Absolute Cutoff	Ends the ultrasonic portion of the cycle when the set absolute distance is reached.
Absolute Distance	The distance the horn has traveled from home (ULS deactivation).
Absolute Mode	A mode of operation in which the ultrasonic portion of the cycle is terminated when a user-specified distance from home has been reached.
Absolute Position	The position of the actuator after clearing the Upper Limit Switch.
Accept-as-is	A disposition permitted for a nonconforming item when it can be established that the item is satisfactory for its intended use without violating safety or functional requirements.
Act Clr Output	Actuator Clear output signal, sent upon the welder reaching a safe position of the actuator return stroke.
Actual	A reported value that occurred during the weld cycle. The converse is the set parameter that was requested during the setup.
Actuator	The unit that houses the converter, booster, and horn assembly in a rigid mounting allowing it to move up and down mechanically to apply a predetermined pressure on the workpiece.
Afterburst	Ultrasonic energy applied after the hold step. Used to break away sticking parts from the tooling.
Alarm Beeper	An audible signal that sounds when a general alarm has occurred.
Alarm Log	A record of alarms that have occurred to the welder. Records time, date, alarm number, and cycle number.
Amp A	The amplitude applied to the part from the start of the weld to the step change.
Amp B	The amplitude applied to the part from the step change to the end of the weld.
Amp Control	The ability to set amplitude digitally or by an external control.

Table 2.1 Glossary of Terms

Name	Description
Amplitude	The peak-to-peak movement at the horn face. Always expressed as a percentage of the maximum.
Amplitude Graph	A graph of amplitude percentage plotted against time.
Amplitude Step	A change in amplitude during the ultrasonic portion of the cycle.
Authority Check	Enables Authority level functions and menus.
Auto Scale Graph	When turned on, the graph will be auto scaled, when off allows X Scale to set scale.
Automatic	A pretrigger condition indicating that pretrigger engages when the actuator leaves the upper limit switch.
Automation	Used in automation when an operator log in is not required. When in automation, weld setup and configuration menus are disabled.
Basic/Expert	Expert (default) allows access to all functions and menus of the welder. Basic limits the configuration and weld setup menus to a minimum number.
Batch Setup	Controls how many parts will be welded in a batch.
Beep	An audible signal produced by the Branson control board. Used to alert the operator to an unexpected condition or that trigger has been reached.
Booster	A one-half wavelength long resonant metal section mounted between the converter and horn, usually having a change in cross-sectional area between the input and output surfaces. Mechanically alters the amplitude of vibration at the driving surface of the converter.
Cal Actuator	Calibrate Actuator. Menus to guide the user through actuator calibration; distance can be verified.
Cal Sensor	The menu title for accessing the calibration and verification of pressure and force.
Clamping Force	The pressure exerted by the horn on the workpiece.
Cold Start	A condition that restores a setup to its default values. Note: Use Carefully.
Collapse Distance	The distance the horn has traveled from the trigger point of ultrasonics.

Table 2.1 Glossary of Terms

Name	Description
Collapse Mode	A mode in which the ultrasonics portion of the cycle is terminated when a user-specified distance from the trigger point has been reached.
Components Verify	Verification, before running a weld, that the system configuration's system components and the weld recipe's system components match.
Control Limits	Additional parameters that determine the end of the ultrasonic portion of the cycle and the move to the hold state.
Converter	The device that converts electrical energy into mechanical vibrations at a high frequency (an ultrasonic rate). The converter is a central component of the welding system and is mounted in the actuator.
Counters	A record of the number of cycles run by category, for example, alarms, good parts, and so on.
Cycle Aborts	Settings that end the cycle immediately.
Digital Filter	A smoothing technique used to provide more meaningful data.
Digital Frequency	A specific starting frequency for a horn. Set to Default (recommended) for factory default starting frequency.
Downspeed	The user-definable speed of descent (percentage of maximum speed) during the down stroke of the actuator.
Downspeed Tuning	Run actuator test cycles for measuring speed and allowing fine adjustments to the speed setting.
Energy Braking	Allows the power supply time to reduce the amplitude before the sonics are shut off. Any overloads that occur will be ignored in this state. They will be handled in the hold state.
Energy Compensation	Extend the weld time up to 50% greater than the weld time setting or whenever the minimum energy is reached, or shut off the weld before the expected (set) weld time if the maximum energy value is reached.
Energy Mode	A mode of operation in which ultrasonics are terminated at a user-specified energy value.
Event History	A record of changes made to the welder configuration and weld setup. Records time, date, user ID and comments made for changes. Used for audit purposes.

Table 2.1 Glossary of Terms

Name	Description
Executive	Highest authority level allowed to the power supply. The Executive has access to all configuration and weld setup features. Only the Executive can create or modify the User ID Setup. Multiple Executive level users can be created in the User ID table. The User ID table must contain at least one Executive user.
External Amplitude Control	Enables you to access real-time amplitude control directly.
External Frequency Control	Enables you to access real-time frequency control directly.
External U/S Delay	If External Trigger Delay is enabled, weld state machine shall wait for external trigger delay input to become active in less than 30 seconds. When the time expires and input is still inactive, alarm will be recorded and cycle aborted.
Extra Cooling	When On, allows cooling air to start when upper limit switch is triggered and remains on throughout the cycle. When Off, air is applied at ultrasonics application.
F Memory	Frequency as stored in the power supply memory. The intended operating frequency value for an ultrasonic stack, stored in the memory of the power supply.
Force	Weld Force. The mechanical force applied to the part during the cycle.
Force Act	Actual Force. The measured mechanical force determined from the results of a weld cycle.
Force Graph	Displays force in pounds as a function of weld time.
Force/Col Graph	Dual display of collapse distance in inches and force in pounds as a function of time.
Freq Chg	Frequency Change. (Frequency at Start versus Frequency at End).
Freq End	The frequency at the end of the ultrasonic portion of the welding cycle (when ultrasonics are terminated).
Freq Max	Maximum Frequency. Highest frequency reached during weld cycle.
Freq Min	Minimum Frequency. Lowest frequency reached during weld cycle.
Freq Start	Frequency at Start. Frequency at the time ultrasonics was turned on.
Frequency	The operating frequency of the ultrasonic stack. The frequency stored is measured at the end of the ultrasonic portion of the cycle (when ultrasonics are terminated).

Table 2.1 Glossary of Terms

Name	Description
Frequency Graph	Displays operating frequency as a function of time.
Frequency Offset	An offset factor applied to the ultrasonic frequency stored in the power supply.
General Alarm	An alarm that occurs due to system fault and/or tripping a limit.
Gnd Det. Mode	Ground Detect Mode, available in all models of 2000Xc Power Supply. In this mode of operation, ultrasonics are terminated after detection of a ground condition between the horn and fixture or anvil.
Ground Det. Cutoff	Ground Detect Cutoff. Immediately terminates the weld process, including the hold step, when a ground detect has occurred.
Hold Force	The force on the part during the hold portion of the cycle.
Hold Pressure	The pressure applied during the hold portion of the cycle. If set to Default, hold pressure equals weld pressure.
Hold Time	The duration of the hold step.
Horn Clamp	If set to ON, the horn will stay down and hold the part in place in the event of an alarm. A Supervisor can reset it and remove the part.
Horn Down	A mode in which ultrasonics are locked out and the user can advance the actuator for setup and alignment.
I/O Connector	Recipes 1 through 32 are available.
Key	Reserved for special product configuration codes.
Linear Encoder	Provides carriage (horn) distance measurement during the actuator cycle.
Main Menu	The list of categories of features available in the software, as displayed on the front panel of the power supply.
Max Energy	Maximum Energy. The maximum user-specified energy that produces a part without an alarm. Used with energy compensation to turn off the weld in Time mode.
Memory Full	Does not allow any welding until memory is cleared. Memory can be cleared by using Copy Now and deleting memory. If set to Continue, the system will write over older memory.

Table 2.1 Glossary of Terms

Name	Description
Min Energy	Minimum Energy. The minimum user-specified energy that produces a part without an alarm. Used with energy compensation to extend the weld to up to 50% of the weld time in Time mode.
Minus Limit	The user-defined lower limit, or lower extreme of an acceptable range for a given parameter. Used with suspect and reject limits.
Missing Part	A min/max distance where trigger is expected. Returns the actuator to the home position and displays an alarm indicating that the cycle was aborted because no part was present.
Operator	Authority level below Technician. The Operator can run a weld and view system information, weld history, and current setup. The Operator cannot access the weld setup or configuration menu.
Operator Authority	Special authority rights granted to operators beyond the basic level of welder operation. The setting for this is global and applies to all operator level users. Multiple Operator level users can be created in the User ID table.
P/Col Graph	Dual Display of% power and collapse distance as a function of time.
P/Force Graph	Dual display of% power and force as a function of time.
Parameter Range	Valid range of parameters accepted for a particular setup.
Part-ID Scan	A USB barcode reader or similar device must read and record the part ID before allowing the weld to occur. When set to ON and after a weld cycle, the welder will stay out of ready mode until another part ID is read. If set to OFF, no part ID reading is required before a weld.
Password Recovery Kit	PRK. A dongle that plugs into the back of the power supply to disable authority check.
Peak Power	A weld mode in which obtaining a power value (percentage of full power) will cause the ultrasonic energy to terminate.
Peak Power Cutoff	A power value that terminates the ultrasonics when peak power is not the primary control mode.
Plus Limit	The user-defined upper limit. See Control Limits, Suspect, Reject and Missing Part Limits.

Table 2.1 Glossary of Terms

Name	Description
Post Weld Seek	Used to determine the operating frequency of the Stack, after the Hold and/or Afterburst portion of the weld cycle. Ultrasonics are run at a low level (5%) amplitude during this step, and the frequency is stored to memory.
Power Graph	A graph of power in percentage of maximum plotted against time.
Pressure Limits	Minimum and Maximum weld pressure limits.
Pressure Step	A change in weld pressure during the ultrasonic portion of the cycle. Pressure A must be less or equal to Pressure B.
Pretrg @ D	The distance at which pretrigger is turned on.
Pretrig Amp	Pretrigger Amplitude. The amplitude at the horn face during pretrigger.
Pretrigger	The setting that causes ultrasonics to start before contact with the part (or, before the set Trigger Force has been met).
Rapid Traverse/ RAPID TRAV	Allows fast actuator descent to a user-defined point, before the Downspeed value is applied for control during the stroke.
Ready Position	State in which the welder is retracted to the home position and ready to receive the start signal, ready to operate.
Recall Recipe	Allows a user to activate a recipe from memory for purposes of operation or modification.
Recipe	User-stored parameters constituting a weld setup. Saved in non- volatile memory in the power supply, can be recalled for quick setup of the system.
Recipe Barcode Start	The character set for the Recipe Barcode Start will indicate a recipe is to be recalled. The number following the character indicates which recipe number. Example; Recipe Barcode Start = P indicates if a barcode reader sees the letter P as the first character of a barcode, it will recall a recipe based on the number after P on the barcode.
Recipe Name	The ability to name a recipe in customer-defined terms.
Recipe, External Selection	Recipes can be changed externally using 5 user inputs on the user
Reject Limits	User-definable limits at which the violating cycle is identified as having produced a bad part.

Table 2.1 Glossary of Terms

Name	Description
Reset Required	State used with limits indicating that a reset will be required when the limit is exceeded. The reset is accomplished by using the reset key on the front of the power supply, or by external reset at the User I/O.
Run Screen	The screen showing weld status, alarms, weld count, and process information. Available using a front-panel button on the power supply.
S-Beam Load Cell	Provides force measurement for accurate ultrasonic triggering and graphing of force.
Scrub Time	In Ground Detect mode, the amount of time after detection of a ground condition before the termination of ultrasonics, and end of the cycle.
Seek	The activation of ultrasonics at a low-level (5%) amplitude, for the purpose of finding the resonant frequency of the Stack.
Setup Limits	Minimum and maximum parameter changes allowed for a weld recipe.
Stack	Converter, Booster, and Horn.
Start Frequency	The frequency stored in memory and the starting frequency of the horn.
Step @ Col (in)	User-definable collapse distance at which AmpA is changed to AmpB.
Step @ E (J)	User-definable energy at which AmpA is changed to AmpB.
Step @ Ext Sig	Allows you to step Amplitude based upon an external signal.
Step @ Pwr (%)	User-definable power at which AmpA is changed to AmpB.
Step @ T (S)	User-definable time at which AmpA is changed to AmpB.
Supervisor	Authority level below Executive. The Supervisor has access to all configuration and weld setup features. Multiple Supervisor level users can be created in the User ID table.
Suspect Limits	User-definable limits at which the resultant weld in a welding cycle is identified as potentially bad (suspect).
SV Interlock	SV Interlock input allows power supply to close an auxiliary door.
Sys Components	System Components. Assign names to the power supply, actuator, and stack. Assigned names will become part of the system configuration and weld recipe.
Technician	Authority level below Supervisor. The supervisor can create and save a weld setup, perform a horn down test, and run diagnostics. The technician cannot validate, lock, or unlock a validated recipe. The technician cannot access the configuration menu. Multiple Technician level users can be created in the User ID table.
Test Scale	The magnification of the power bar on the front panel of the power supply, useful for lower-power applications that want a more accurate (but smaller) scale.
Time Mode	Terminates the ultrasonics at a user-specified time.
Timeout	A time at which the ultrasonic energy terminates if the main control parameter has not been reached.

Table 2.1 Glossary of Terms

Name	Description
Trig Delay	Trigger Delay. A user-programmable time delay between engagement of the trigger switch and start of ultrasonics and ramping of force to the weld force.
Trigger	Trigger force triggers the start of ultrasonics based on a set force level. Trigger distance triggers the start of ultrasonics based on a set travel distance. Trigger distance doesn't consider force when used.
Trigger Beeper	An audible signal sounded when the trigger is made.
Upper Limit Switch (ULS)	A switch when activated indicates the actuator is in the home position.
UPS	Power supply module.
USB Copy Now	Allows a PDF copy of weld history, event history, weld setup, and User ID table to be copied to a USB flash drive. The flash drive must be installed for this function to appear.
USB Streaming Data Setup	Allows real time recording of weld data and graphs to a USB flash drive. The weld data and graphs can be viewed on a PC using the Branson Weld History Utility Program.
User I/O	The User I/O is used to configure actuator inputs and outputs. This menu can only be entered when the welder is not in a weld cycle.
User ID Setup	Add and modify users allowed access to the power supply.
User-defined Limits	<p>For process resultants, where - is the user-defined lower limit, and + is the user defined upper limit:</p> <ul style="list-style-type: none"> • -/+ S/R Energy: The energy reached during the weld • -/+ Force: The force at the end of the weld • -/+ S/R Freq: The peak frequency reached during a weld • -/+ S/R Power: The peak power as a percentage of the maximum reached during the weld • -/+ S/R Abs D: The absolute distance reached during the weld from the Upper Limit Switch • -/+ S/R Col D: The collapse distance reached from trigger to end of weld • -/+ S/R Trg D: The distance at which the trigger occurred • -/+ S/R Time: The weld time reached during the weld
Velocity Graph	A graph of the velocity of the actuator during weld.
View Setup	Available in Main Menu as a read only menu identical to the Weld Setup menu. It is not password protected even if the Weld Setup menu is protected.
Weld Count	Count of acceptable weld cycles.
Weld Energy	The energy specified to be applied to the part during the weld cycle.
Weld Force	The force at the end of the weld cycle.
Weld History	The last 100,000 weld summary data lines are saved.
Weld History Setup	Selects which characteristics will appear in the power supply Weld History screen.
Weld Results	A summary of information concerning the last weld cycle.
Weld Scale	The power bar LED scale during weld.
Weld Time	The time for which ultrasonics are on.

Table 2.1 Glossary of Terms

Name	Description
Windows Setup	Allows access to the Microsoft Windows screen.
Write In Fields	Assign a unique alphanumeric to a specific weld setup and cycle.
X Scale Graph	Allows a scaling factor to be applied when auto scale is turned off.

[This page intentionally left blank]

Chapter 3: Technical Specifications

3.1 Technical Specifications46
3.2 Physical Description49

3.1 Technical Specifications

NOTICE	
	All specifications are subject to change without notice.

3.1.1 Environmental Specifications

The GSX-E1 System has the following environmental specifications:

Table 3.1 Environmental Specifications

Environmental Condition	Acceptable Range
Ambient Operating Temperature	+5°C to +40°C
	+41°F to +104°F
Storage / Shipping Temperature	-25°C to +55°C
	-13°F to +131°F
Operating Altitude	2000 m
	6561 ft
Humidity	Maximum 85%, non-condensing
IP Rating	2X

3.1.2 Electrical Specifications

3.1.2.1 GSX-E1 System

[GSX-E1 System Input] = [Power Supply Input] + [Auxiliary Box]

Table 3.2 Input Current

Model	Power	System Input
20 kHz	2050 W	200-240V~11 A 50/60Hz, Single Phase
	3300 W	200-240V~18A 50/60Hz, Single Phase
	4800 W*	200-240V~29A 50/60Hz, Single Phase
30 kHz	2300 W	200-240V~14A 50/60Hz, Single Phase
40 kHz	1600 W	200-240V~9A 50/60Hz, Single Phase

*200 VAC Min. for 4000 W units.

3.1.2.2 Continuous Duty Maximum Power - Power Supply

Table 3.3 Continuous Duty Maximum Power - Power Supply

Model	Power	Continuous Duty Max. Power	Full Power Duty Cycle
20 kHz	1250 W	800 W	10 seconds on, 10 seconds off (50% duty cycle)
	2500 W	1600 W	10 seconds on, 10 seconds off (50% duty cycle)
	4000 W	2000 W	5 seconds on, 15 seconds off (25% duty cycle)
30 kHz	1500 W	800 W	2 seconds on, 2 seconds off (50% duty cycle)
40 kHz	800 W	400 W	10 seconds on, 10 seconds off (50% duty cycle)

NOTICE



High duty cycles require additional cooling for the converter. For information on converter cooling refer [4.14 Converter Cooling](#).

NOTICE



System average power must be limited to the specified continuous maximum.

3.1.2.3 Force vs Time Recommendations

Table 3.4 Force vs Time Recommendations

Force (N)	*On Time	Duty Cycle	Off Time
1200 N or less	Unlimited	100%	-
1500 N or less	7 seconds	60%	4.7 seconds
2000 N or less	2 seconds	50%	2 seconds
2500 N or less	0.5 seconds	30%	1.2 seconds

*On Time includes: Weld + Hold Time

3.2 Physical Description

This section describes the physical dimensions of the GSX-E1 System.

NOTICE	
	Dimensions are nominal.

Table 3.5 Dimensions and Weights of GSX-E1 System

Model	Width	Height	Depth	Weight
All models	48 cm	148 cm	68 cm	113 kg
	19 in	58 in	27 in	248 lb

For detailed dimensional information refer to [3.2.1 Dimensional Drawings](#).

3.2.1 Dimensional Drawings

Figure 3.1 Front Side

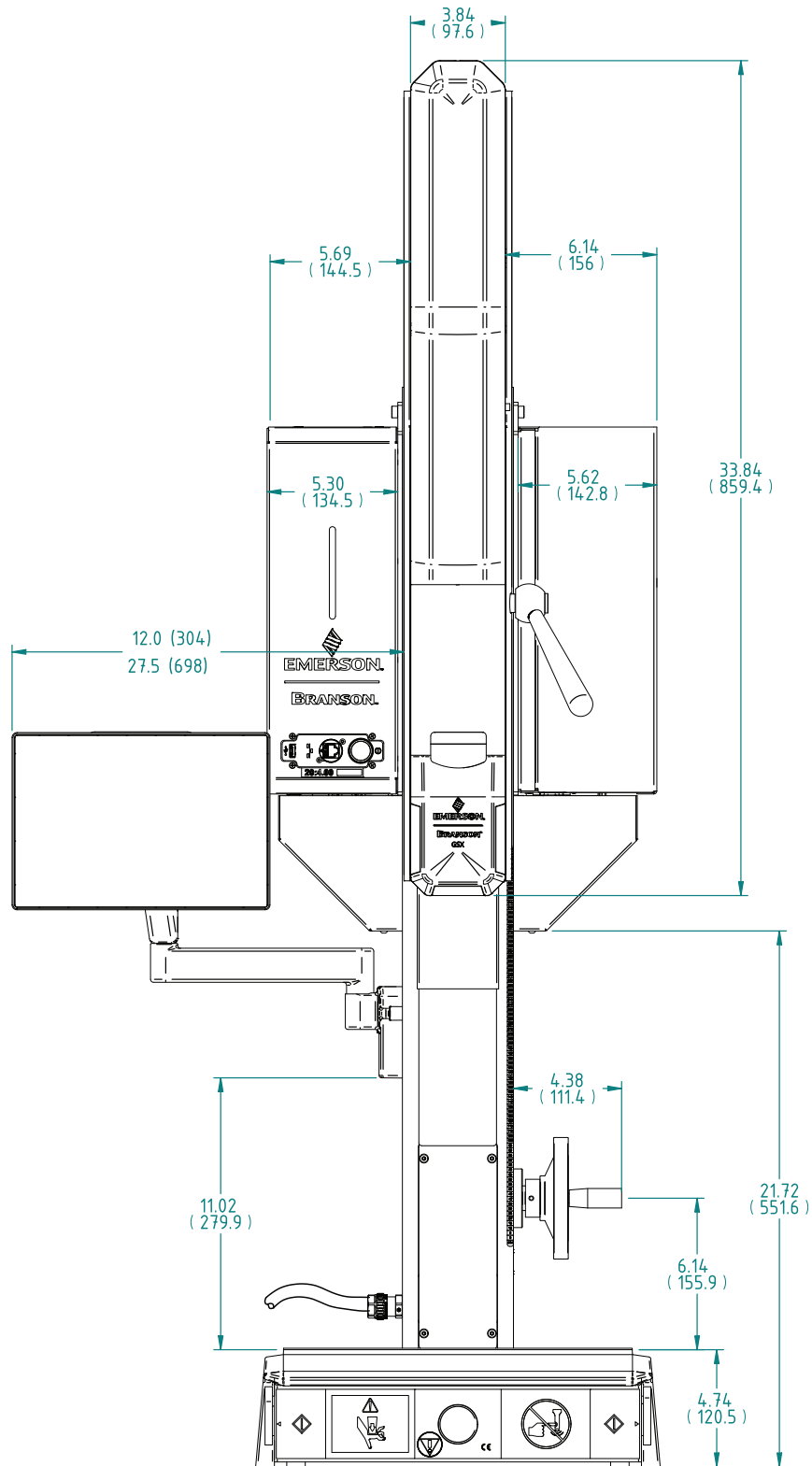

Figure 3.2 Left Side

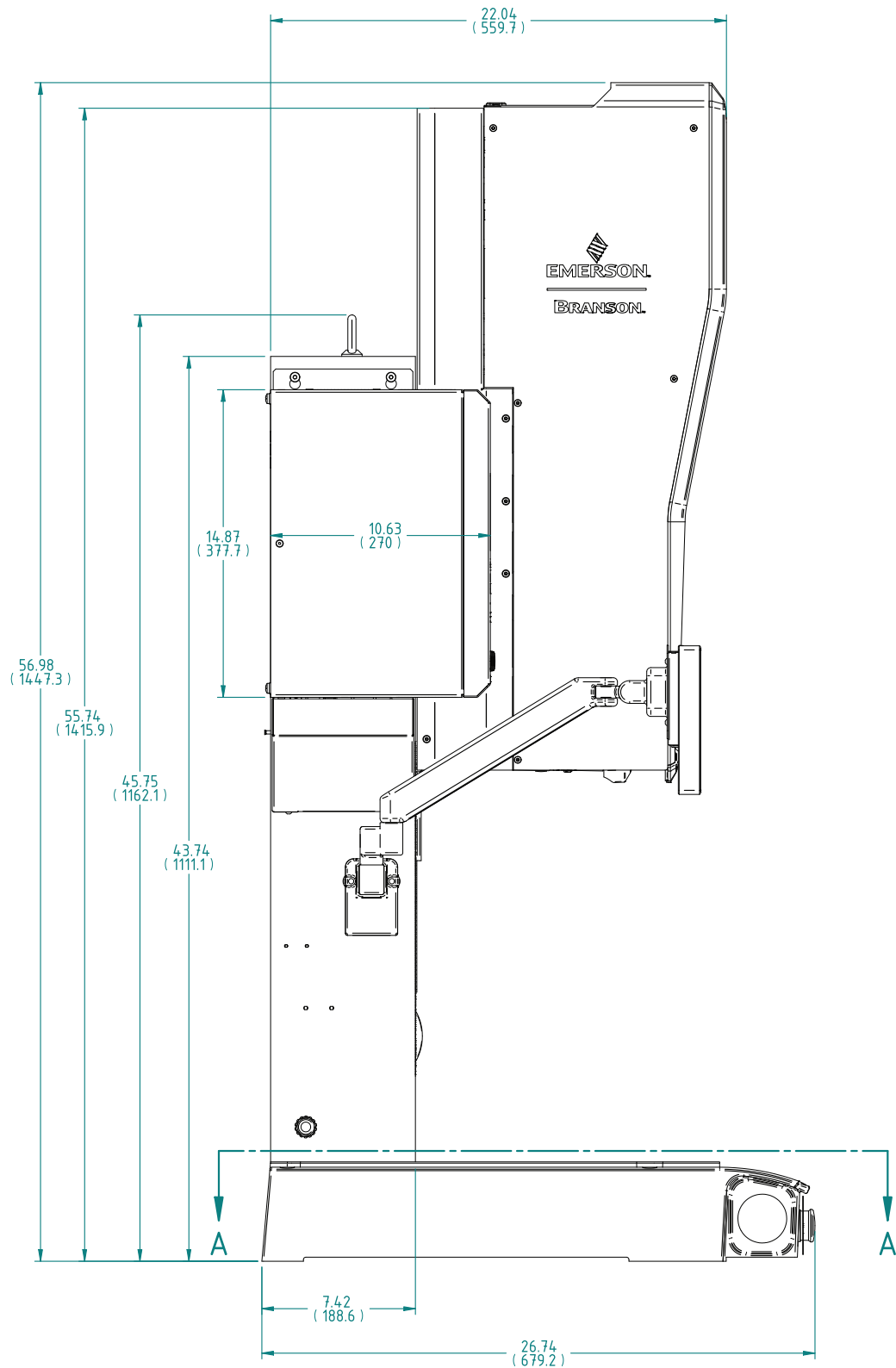

Figure 3.3 Right Side

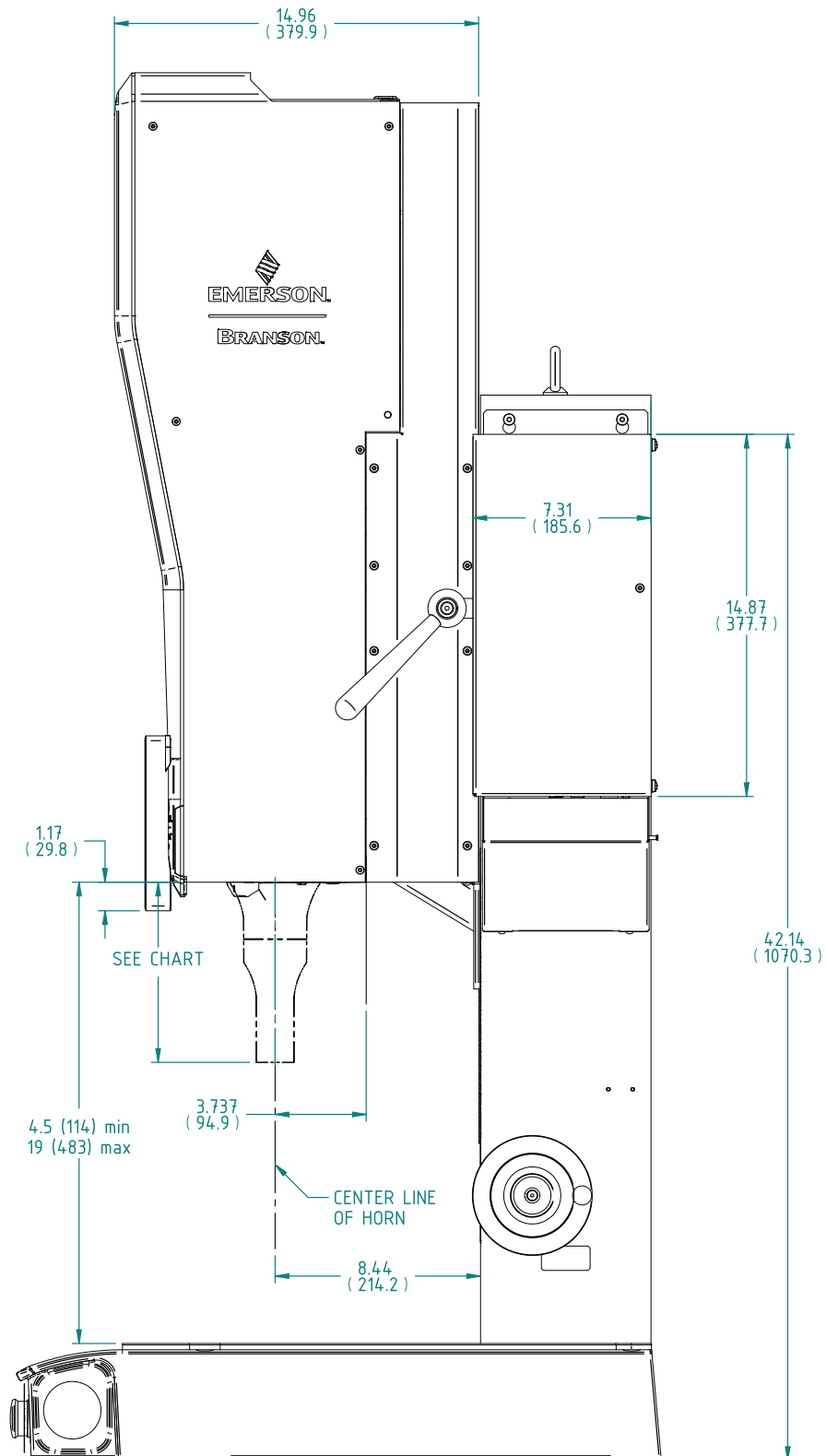

Figure 3.4 Back Side

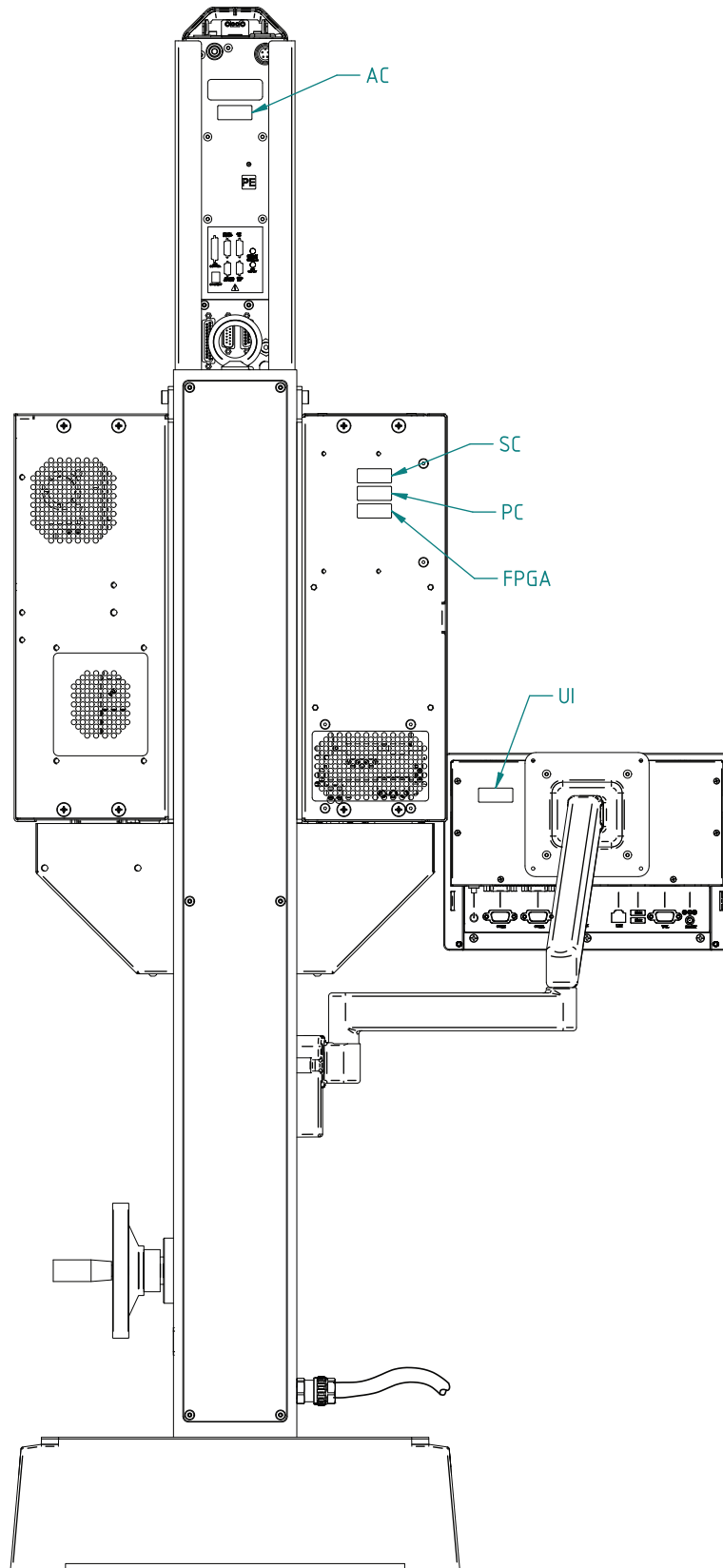
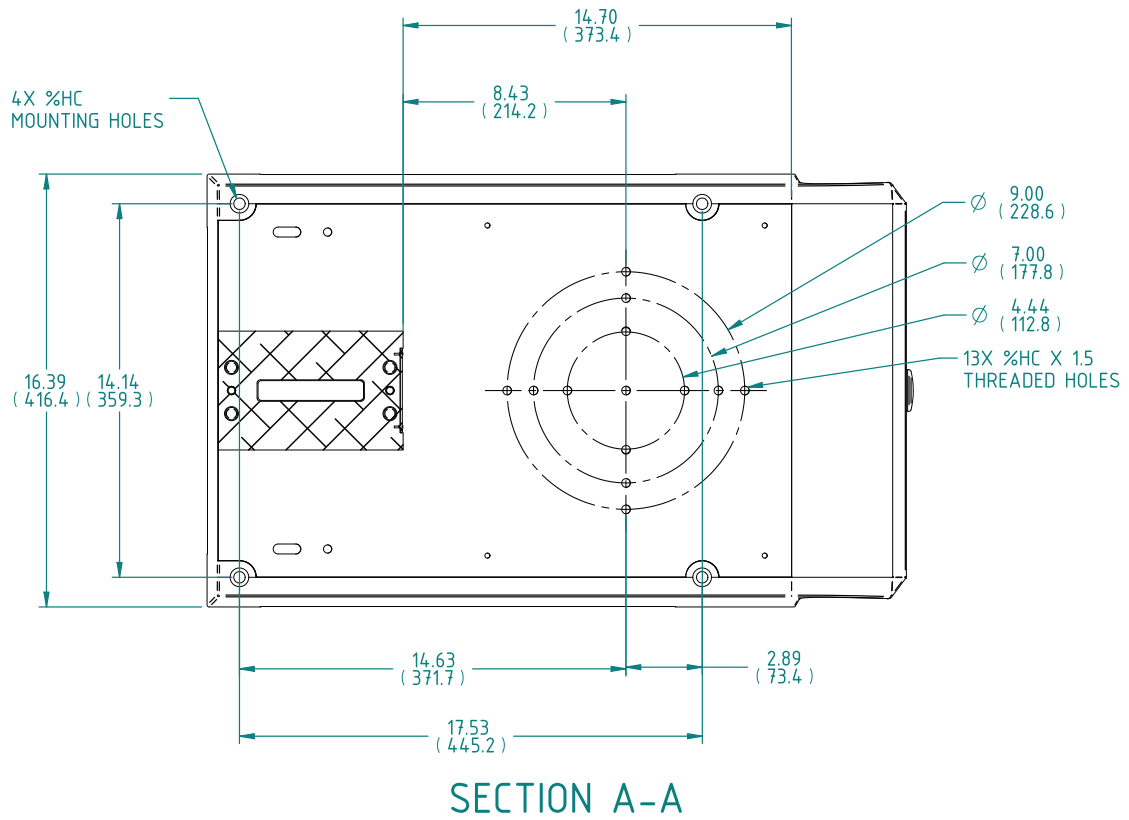

Figure 3.5 Base



Chapter 4: Installation and Setup

4.1	About Installation	56
4.2	Installation Requirements	57
4.3	Installation Steps	58
4.4	HMI Touchscreen Monitor	60
4.5	Interface Points	63
4.6	Input Power Connection	66
4.7	User I/O	69
4.8	Ground Detect Cable	73
4.9	Safety Equipment	74
4.10	Acoustic Stack	75
4.11	Installing the Ultrasonic Stack in the Actuator	87
4.12	Mounting the Fixture on the Base	89
4.13	Adjusting Welder Height and Aligning the Horn	90
4.14	Converter Cooling	92
4.15	LED Lamp	94
4.16	USB Accessories	95
4.17	Barcode Scanner	96
4.18	Password Recovery Kit	98

4.1 About Installation

This chapter is intended to help the installer with the basic installation and setup of your GSX-E1 system.

This chapter covers the location options, dimensions of the major assemblies, environmental requirements, electrical requirements and factory air requirements, to help you plan and execute your installation successfully.

International safety labels are found on the GSX-E1 system. Those that are of importance during installation of the system are identified in the figures in this and other chapters of the manual.

4.2 Installation Requirements



CAUTION	Heavy Object
	<p>The GSX-E1 system is heavy and can cause a pinching or crushing injury during installation or adjustment. Keep clear of moving parts and do not loosen clamp unless directed to do so.</p> <p>Handling, unpacking, and installation can require help or the use of lifting platforms or hoists.</p> <p>Use the lift point to interface with lifting equipment.</p> <div style="text-align: center;">  </div>

Table 4.1 Lift Point Location

Item	Description
1	Lift Point

4.2.1 Location

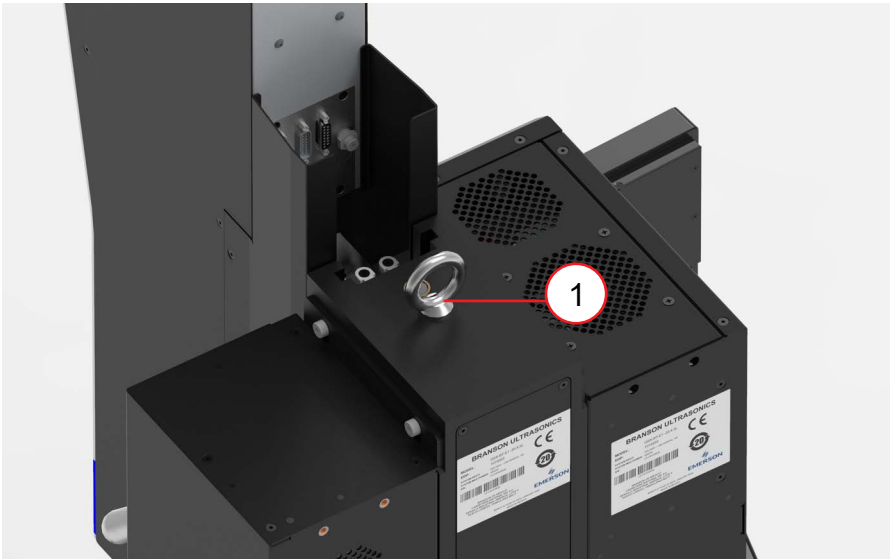
The GSX-E1 system should only be operated in the vertical position. The system is manually operated, using its base-mounted start switches, and so is installed at a safe and comfortable workbench height with the operator sitting or standing in front of the system.

WARNING	
	<p>The stand may tip over if not properly secured. The work surface on which a stand is installed must be sturdy enough to support it, and secure enough to not tip over when the stand is adjusted during installation or setup.</p>

4.3 Installation Steps

4.3.1 Mounting the Stand

The base must be bolted to your workbench to prevent tipping or undesired movement. Four mounting bolt holes are provided at the corners of the casting, and will accept your M10 cap screws. Use flat washers against the metal casting to prevent gouging.

CAUTION



You must secure the base to your work surface using four bolts, to prevent tipping or undesired movement.

Table 4.2 Mounting the Stand

Step	Action
1	Ensure there are no overhead obstructions and that no pinch or rub points exist. Remember that the welder is taller than the column when fully raised, and there are exposed connections
2	Mount the base to your workbench using four M10 socket-head cap screws. Use flat washers against the metal casting to prevent gouging. The use of nylon lock nuts with your cap screws is suggested, to reduce loosening due to vibration and movement. See Figure 4.1 .

Figure 4.1 Base mounting centers

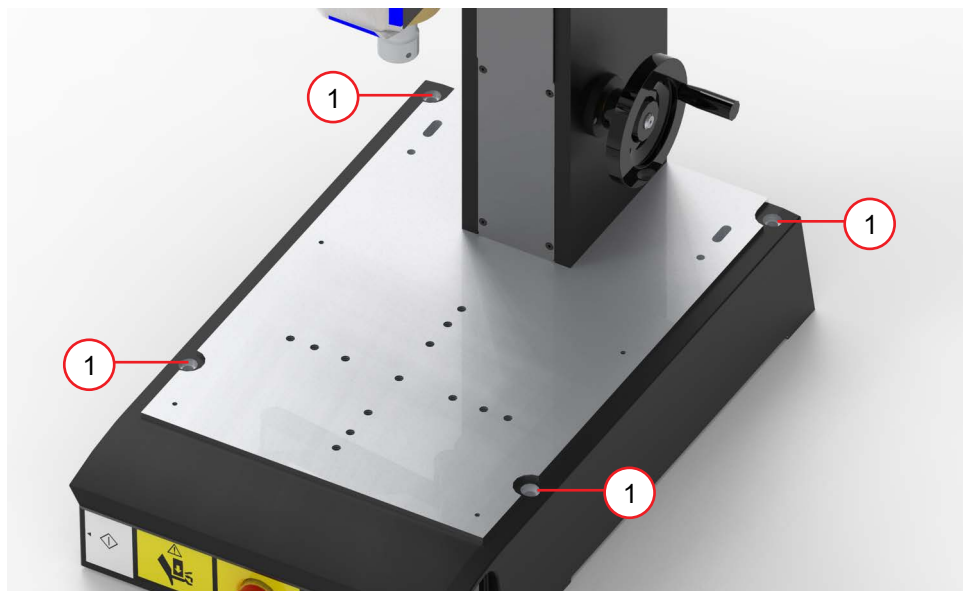
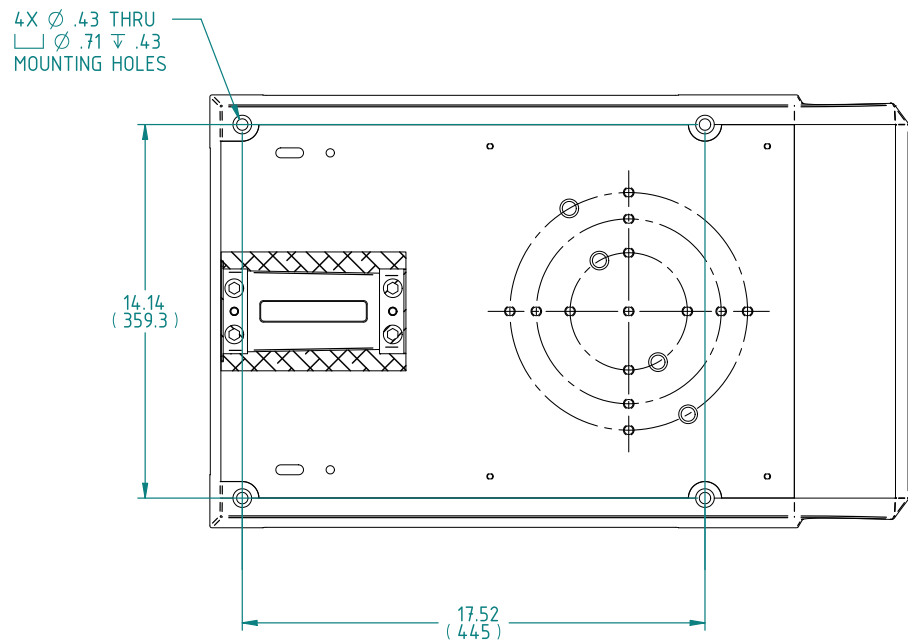

Table 4.3 Location of base mounting centers

Item	Description
1	Base mounting centers

4.4 HMI Touchscreen Monitor

4.4.1 Attaching Touchscreen to Arm

Table 4.4 Attaching Touchscreen to Arm

Step	Action
1	Tilt the monitor back and lower onto the arm, so that the hook fits into the corresponding hole on the VESA bracket. Then rotate the bottom of the monitor back towards the arm until the tab snaps in place.
2	To remove, lift the release tab and pull the bottom of the monitor away from the arm, then lift free of the hook.
3	Connect power cable to the DC Input on the back of the touchscreen. See section 4.4.2 Touchscreen Connections to locate the DC Input.
4	Connect Ethernet cable to the RJ-45 LAN port on the back of the touchscreen. See section 4.4.2 Touchscreen Connections to locate the RJ-45 LAN port.

Figure 4.2 Attaching Touchscreen to Arm

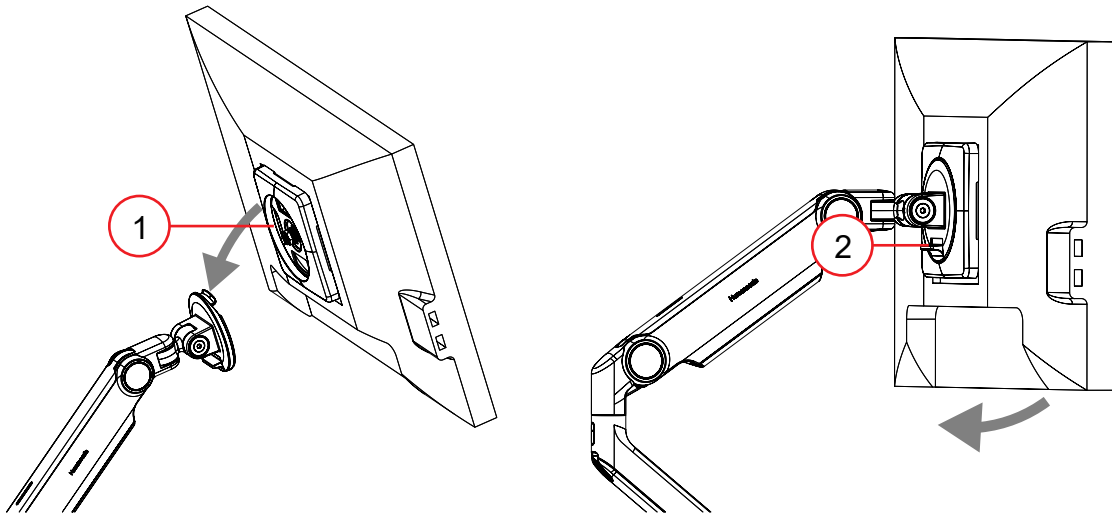

Table 4.5 Arm

Item	Description
1	VESA bracket
2	Release tab

4.4.1.1 Arm Adjustments

The monitor should move up and down easily and stay in place once adjusted. If it is difficult to adjust or moves without assistance, it is not properly counter balanced.

Table 4.6 Arm Adjustments

Step	Action
1	Press the upper arm link downward until you see the adjustable screw.
2	Adjust the screw with a 4 mm hex key clockwise direction (towards +) to increase load tension and anticlockwise (towards -) to reduce load tension. NOTICE Do not over-tighten the screw as it can damage the screw head or thread. NOTICE Remove hex key before moving the arm to avoid damage to the hinge area.
3	Move the monitor around to ensure that movement is smooth and the arm functions as desired. If required, repeat steps 1-2 to adjust the force as needed.

Figure 4.3 Arm Adjustments

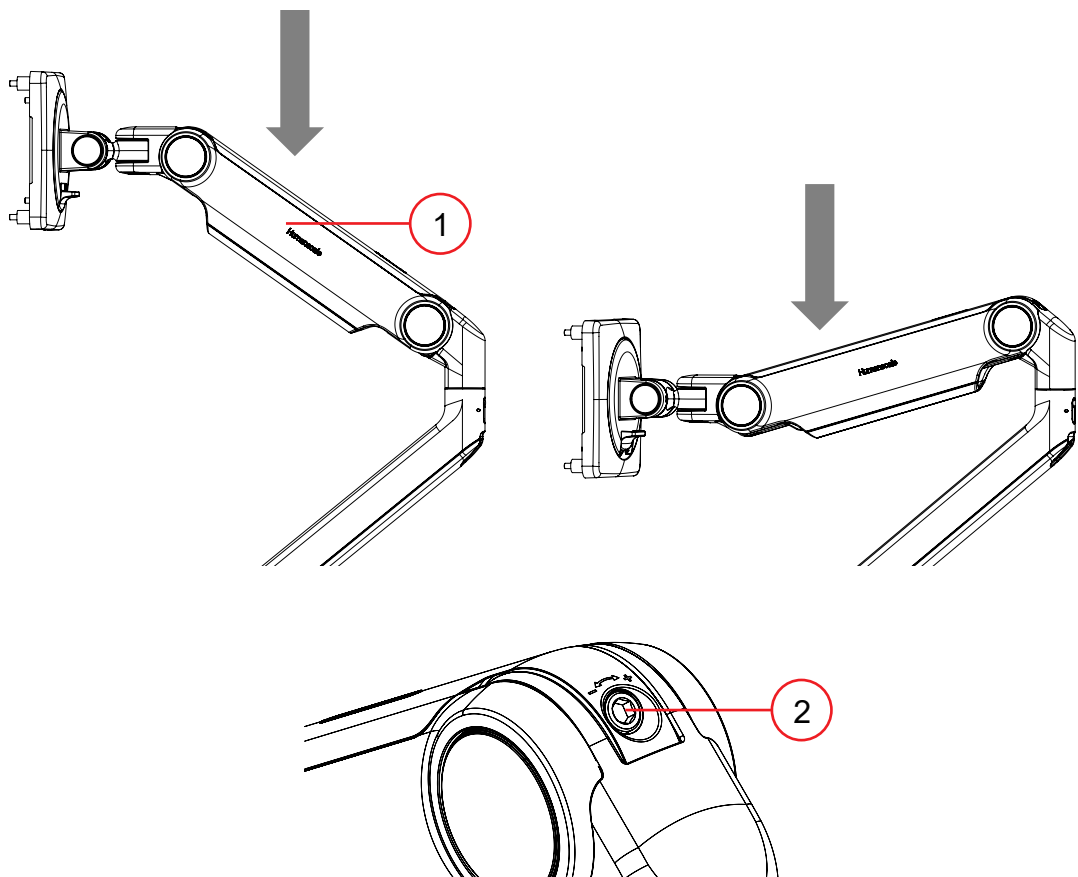

Table 4.7 Arm Screws

Item	Description
1	Upper arm link
2	Adjustable screw

4.4.2 Touchscreen Connections

Figure 4.4 HMI Interface Points

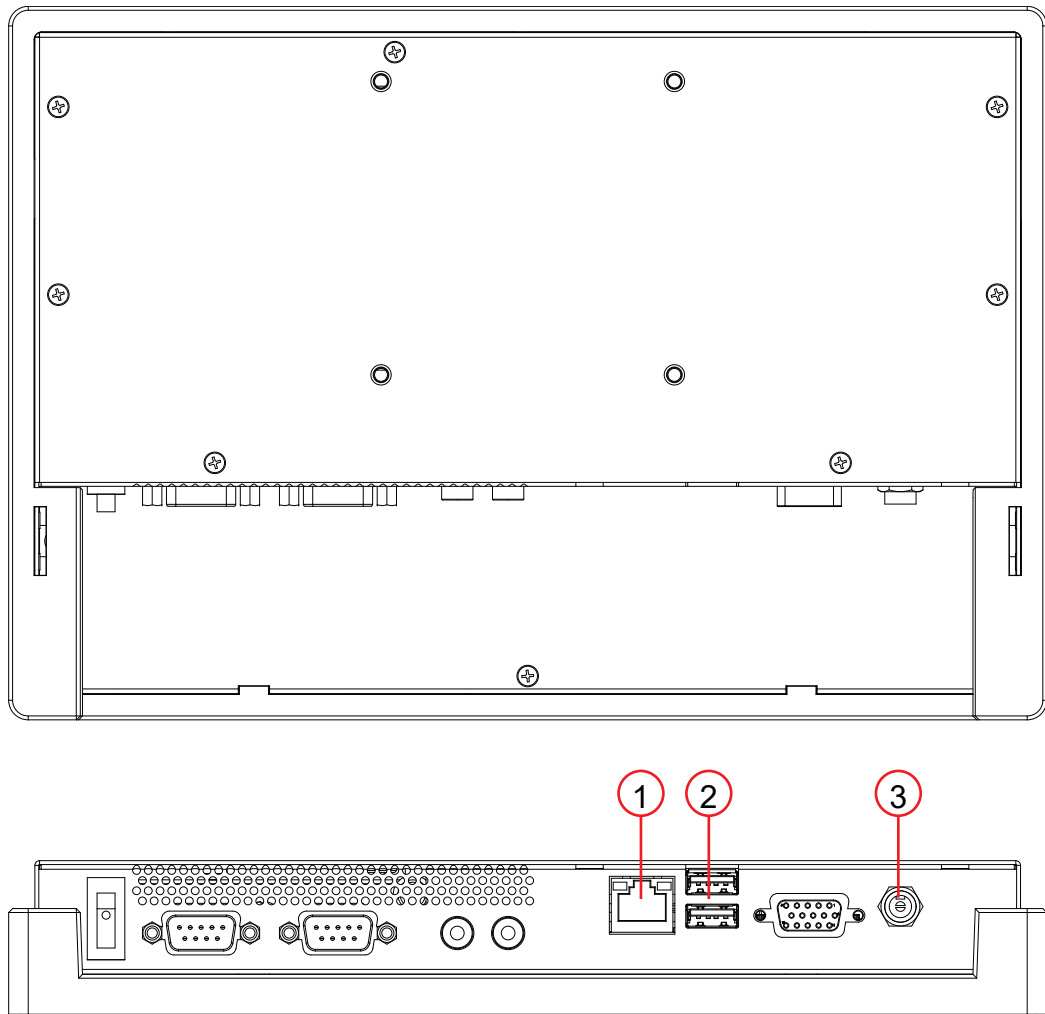

Table 4.8 Touchscreen Connections

Item	Description
1	LAN Port
2	USB 2.0/USB 3.0 Ports
3	DC Input

NOTICE



USB ports on the HMI are for keyboards and mice only. Do not use any other kind of device into these ports.

4.5 Interface Points

4.5.1 Actuator

Figure 4.5 GSX-E1 Actuator Cable Interface Points

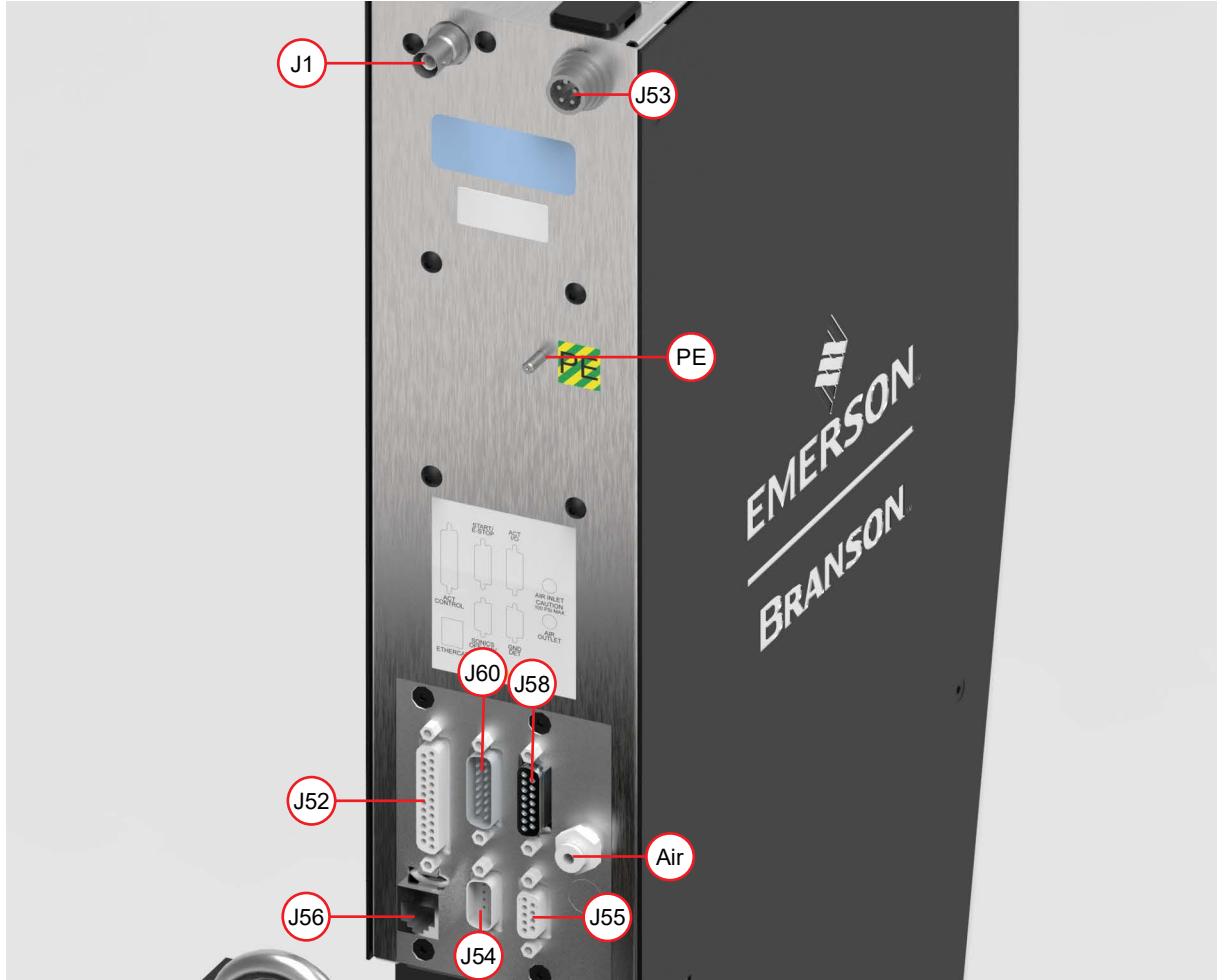

Table 4.9 GSX-E1 Actuator Cable Interface Points

Connection Point	Description	Cable Required/Notes
J1	RF In	SHV RF J1 Cable
J52	Servo Control	Servo-Control Cable
J53	Servo Power In	Servo-Power Cable
J54	Sonics Status In/24 VDC Actuator In	Sonics Off/24 V Actuator Cable
J55	Ground Detect	Ground Detect Cable
J56	P/S-Actuator Comm	EtherCAT Cable
J58	Actuator I/O	Actuator I/O Cable
J60	E-Stop, Cycle Start	Remote Start Cable
PE	Earth Ground	Ground Actuator - M4 stud
Air	Converter Cooling Air Input	Air Fitting - 4 mm tube

4.5.2 Power Supply

Figure 4.6 GSX-E1 Power Supply Cable Interface Points



Table 4.10 GSX-E1 Power Supply Cable Interface Points

Connection Point	Description	Cable Required/Notes
J1	RF Out	SHV RF J1 Cable
J2	Main Supply Voltage Input	Power Supply Line Cord
J3	24 VDC Power Supply In	24 V Power Supply Cable
J9	Auxiliary Box AC Supply	Auxiliary Box to Power Supply
J15	P/S-Actuator Comm	EtherCAT Cable
J16	12 VDC HMI Out	12 V HMI Cable
J17	Power Supply I/O	Power Supply I/O Cable
J23	Ethernet Monitor	Ethernet Cable
J72	24 VDC Actuator Out	Sonics Off/24 V Actuator Cable

4.5.3 Auxiliary Box

Figure 4.7 GSX-E1 Auxiliary Box Cable Interface Points





Table 4.11 GSX-E1 Auxiliary Box Cable Interface Points

Connection Point	Description	Cable Required/Notes
J2	Main Supply Voltage Input	Auxiliary Box to Power Supply
J3	24 VDC Power Supply Out	24 V Power Supply Cable
J70	Servo Control	Servo-Control Cable
J73	Servo Power Out	Servo-Power Cable

4.6 Input Power Connection



4.6.1 Power Supply

Use the following procedure to connect the power supply to a single-phase, grounded, 3-wire, 50/60 Hz 200/230 VAC power source. See section [3.1.2 Electrical Specifications](#) for more information.



DANGER	
	<p>Ensure all electrical power is off when wiring input power to the power supply connector block. To prevent the possibility of an electrical shock, ground the power supply by securing an AWG 8 grounded conductor to the ground screw located on the back of the actuator.</p>
DANGER	
	<p>If mis-wired, the power supply can present an electrical shock hazard.</p>
CAUTION	
	<p>The power supply can be permanently damaged if it is connected to the incorrect line voltage, or if the connection is mis-wired.</p>

4.6.2 Auxiliary Box

Use the following procedure to connect the auxiliary box to a single-phase, grounded, 3-wire, 50/60 Hz 200/230 VAC power source. See section [3.1.2 Electrical Specifications](#) for more information.

DANGER	
	<p>Ensure all electrical power is off when wiring input power to the auxiliary connector block. To prevent the possibility of an electrical shock, ground the power supply by securing an AWG 8 grounded conductor to the ground screw located on the back of the actuator.</p>
DANGER	
	<p>If mis-wired, the auxiliary box can present an electrical shock hazard.</p>
CAUTION	
	<p>The auxiliary box can be permanently damaged if it is connected to the incorrect line voltage, or if the connection is mis-wired.</p>

4.6.3 Input Power Plug

NOTICE	
	<p>End user is responsible for installation of a plug onto the provided line cords. The provided plug must conform to the relevant specifications and safety requirements for the specific region the unit will be installed. See section 3.1.2 Electrical Specifications for more information.</p>
WARNING	
	<p>The power supply and auxiliary box can be permanently damaged if it is connected to the incorrect line voltage, or if the wiring connection is mis-wired. It also presents a safety hazard if mis-wired.</p>
WARNING	
	<p>If permanently connecting equipment (without a power plug), use appropriate disconnect for this purpose, which conforms to local regulatory requirements.</p>

If you add an input power plug, use the following color code for the conductors found in the international harmonized line cord. Add the plug that is appropriate for your input receptacle.

Figure 4.8 International Harmonized Line Cord Color Code

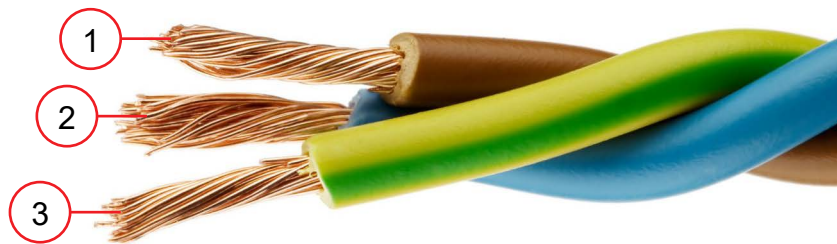



Table 4.12 Line Cord Color Code

Item	Description
1	Brown - Line
2	Blue - Neutral
3	Green/Yellow - Protective Earth (PE)

4.7 User I/O

The user I/O is an interface for automation. It provides the ability to make your own interface for your automation, actuator interface, special control, or reporting needs.

CAUTION	
	<p>All unused wires must be individually electrically isolated from each other. Failure to properly isolate or incorrect wiring can cause the system controller board to fail.</p>

CAUTION	
	<p>Ensure Ground pins and +24 VDC pins are wired correctly. Failure to properly wire these pins will cause damage to the system controller board.</p>

4.7.1 Power Supply I/O Connection

The interface cable has a 26-pin HD male D-Sub connector on one end, and wires on the other end. Pins are wired to ICEA standard color code.

See [Table 4.15](#) for the default user I/O pin assignments.

Figure 4.9 Power Supply User I/O Cable Identification and Wire Color Diagram

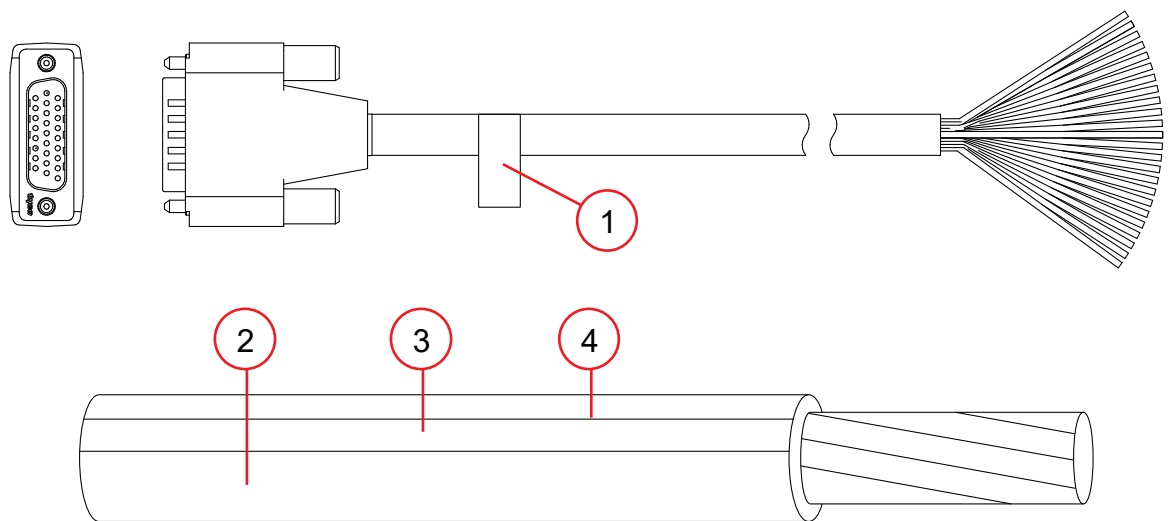

Table 4.13 User I/O Cable

Item	Description	Item	Description
1	Part number	3	Stripe
2	Insulation	4	Dot

4.7.2 Actuator I/O Connection

The interface cable has a 15-pin HD male D-Sub connector on one end, and wires on the other end. Pins are wired to ICEA standard color code.

See [Table 4.16](#) for the default user I/O pin assignments.

Figure 4.10 User I/O Cable Identification and Wire Color Diagram

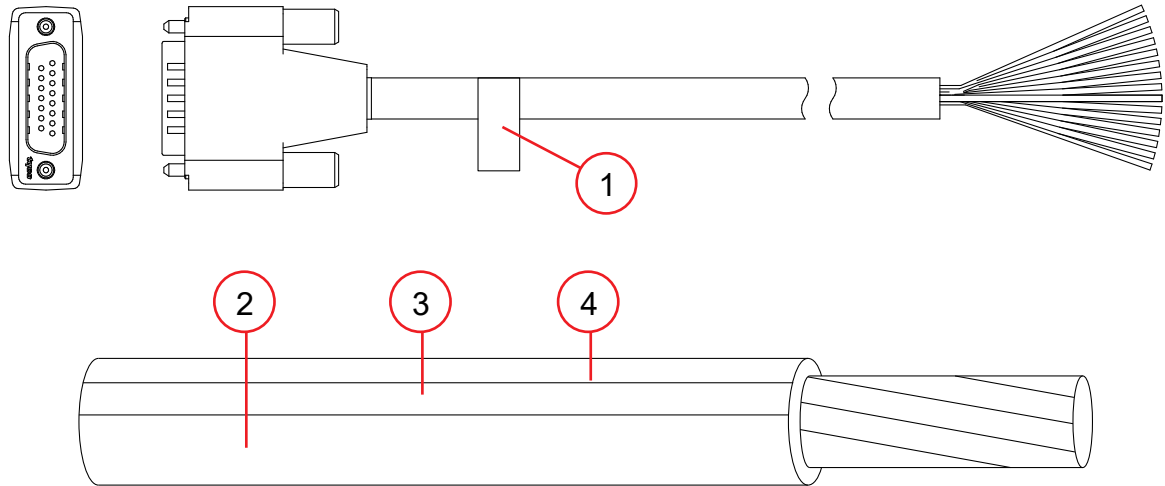

Table 4.14 User I/O Cable

Item	Description	Item	Description
1	Part number	3	Stripe
2	Insulation	4	Dot

4.7.3 Power Supply User I/O Cable Pin Assignments

Table 4.15 Default Power Supply I/O Configurations

Pin	Input/Output	Default Function	Signal Range	Cable Color (IEC)
1	Digital Input	Cycle Abort	0 VDC or 24 VDC \pm 10% 12 mA	BLK
2	Digital Input	U/S Disable		WHT
3	Digital Input	Reset		RED
4	Digital Input	N/A		GRN
5	+24VDC SRC	Supplied from GSX-E1 System	24 VDC \pm 10% 250 mA Max	ORG
6	+24VDC SRC			BLU
7	Digital Output	Ready	0 VDC or 24 VDC \pm 10% 25 mA Max	WHT/BLK
8	Digital Output	Sonics Active		RED/BLK
9	Digital Output	General Alarm		GRN/BLK
10	Digital Output	Cycle Running		ORG/BLK
11	Digital Input	Hold Delay	0 VDC or 24 VDC \pm 10% 12 mA	BLU/BLK
12	Digital Input	Horn Seek		BLK/WHT
13	Digital Input	N/A		RED/WHT
14	Gnd	+24 VDC Common	0 VDC	GRN/WHT
15	Gnd			BLU/WHT
16	Digital Input	N/A	0 VDC or 24 VDC \pm 10% 12 mA	BLK/RED
17	Not Used	N/A	N/A	WHT/RED
18	Not Used	N/A	N/A	ORG/RED
19	Digital Output	Horn Seek	0 VDC or 24 VDC \pm 10% 12 mA Max	BLU/RED
20	Digital Output	Cycle OK		RED/GRN
21	Digital Output	Suspect Alarm		ORG/GRN
22	Digital Output ²⁴	Reject Alarm		BLK/WHT/RED
23	Digital Input	N/A	0 VDC or 24 VDC \pm 10% 12 mA	WHT/BLK/RED
24	Not Used	N/A	N/A	RED/BLK/WHITE
25	Not Used	N/A	N/A	GRN/BLK/WHT
26	Gnd	+24VDC Common	0 VDC	ORG/BLK/WHT

4.7.4 Actuator User I/O Cable Pin Assignments

Table 4.16 Actuator User I/O Cable Pin Assignments

Pin	Input/Output	Default Function	Signal Range	Cable Color (IEC)
1	Digital Input	N/A	0 VDC or 24 VDC \pm 10% 12 mA	BLK
2	Digital Input	Part Present		WHT
3	Digital Input	Home Position		RED
4	+24VDC SRC	Supplied from GSX-E1 System	24 VDC \pm 10% 500 mA Max	GRN
5	Digital Output	Home Position	0 VDC or 24 VDC \pm 10% 25 mA Max	ORG
6	Digital Output	Ready Position		BLU
7	Digital Output	PB Release		WHT/BLK
8	Gnd	+24VDC Common	0 VDC	RED/BLK
9	Digital Input	Ready Position	0 VDC or 24 VDC \pm 10% 12 mA	GRN/BLK
10	Digital Input	N/A		ORG/BLK
11	Not Used	N/A	N/A	BLU/BLK
12	GND	+24VDC Common	0 VDC	BLK/WHT
13	Digital Output	N/A	0 VDC or 24 VDC \pm 10% 25 mA Max	RED/WHT
14	Digital Output	N/A		GRN/WHT
15	+24VDC SRC	Supplied from GSX-E1 System	24 VDC \pm 10% 250 mA Max	BLU/WHITE

4.8 Ground Detect Cable

The interface cable has a 9-pin female D-Sub connector on one end, and wires on the other end.



CAUTION	
	All unused wires must be individually electrically isolated from each other. Failure to properly isolate or incorrect wiring can cause the system controller board to fail.
CAUTION	
	Ensure Ground pins and +24 VDC pins are wired correctly. Failure to properly wire these pins will cause damage to the system controller board.

Figure 4.11 Ground Detect Cable

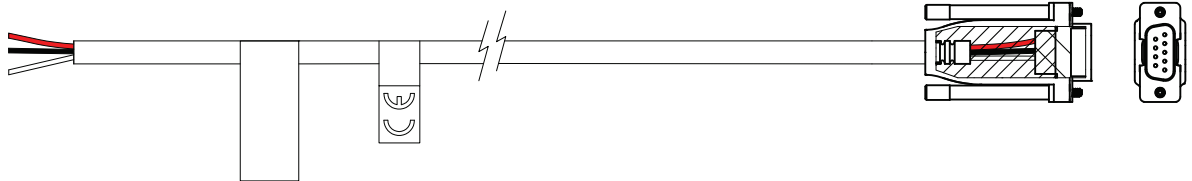

Table 4.17 Ground Detect Cable

Pin	Signal	Cable Color
1	+24 VDC	Red
2	Ground	Black
3	Ground Detect	White

4.9 Safety Equipment

4.9.1 Emergency Stop Control

If you use the emergency stop button on the system to terminate a weld, twist the button to reset it. (The welder will not operate until this button is reset). If you are running automation, you can use external reset that is connected to your User I/O board.

NOTICE	
	<p>If emergency stop button is pressed during motion, system needs to be powered off and on.</p>

Figure 4.12 Emergency Stop Button



Table 4.18 Emergency Stop Button

Item	Description
1	Emergency Stop Button

4.10 Acoustic Stack

4.10.1 Torque Wrench Kit

Welding systems function with greatest efficiency when the stack components (converter, booster, and horn) are properly assembled and torqued.

Figure 4.13 Torque Wrench Kit



Benefits

- Ensures proper torque and eliminates failures from improper torquing
- Can be calibrated
- Reduces maintenance required because stacks are assembled correctly

Torque Guidelines

The charts in this section provide guidelines for applying torque with the kit.

4.10.2 Safety

CAUTION	
	<p>The following procedure must be performed by a trained operator. If necessary, secure the largest portion of a square or rectangular horn in a soft jawed (brass or aluminum) vise. NEVER attempt to assemble or remove a horn by holding the converter housing or the booster clamp ring in a vise.</p>

CAUTION	
	<p>Do not use silicone grease with Mylar washers. Use only 1 (one) Mylar washer of the correct inside and outside diameters at each interface.</p>

4.10.3 Tool Kits and Miscellaneous

4.10.3.1 Torque Wrench Kit #1

For 20 kHz and 30 kHz acoustic stacks (EDP 101-063-787):

Table 4.19 Torque Wrench Kit #1

Replacement Parts	EDP
Torque Wrench	200-118-037
3/8" Adapter	200-121-067
3/16" Hex and Bit Driver	200-038-099
1/4" Hex and Bit Driver	200-038-098
Adapter, 20 kHz	100-115-082
Adapter, 30 kHz	100-115-088
1 1/4" Open end Wrench	200-121-071

4.10.3.2 Torque Wrench Kit #2

For 40 kHz Acoustic Stacks (EDP 101-063-618):

Table 4.20 Torque Wrench Kit #2

Replacement Parts	EDP
Torque Wrench	200-118-038
3/8" Adapter	200-121-067
5/32" Hex and Bit Driver	200-038-097
Adapter, 40 kHz	100-115-081

4.10.3.3 Miscellaneous

Table 4.21 Miscellaneous

Tool	EDP
20 kHz Spanner Wrench	201-118-019
30 kHz Spanner Wrench	201-118-033
40 kHz Spanner Wrench	201-118-024
Adjustable Face Spanner	201-118-027
Silicone Grease	101-053-002
Mylar Washer 150 CT for Kit 1/2"	100-063-471
Mylar Washer 150 CT for Kit 3/8"	100-063-472

4.10.4 Assembly Instructions

4.10.4.1 Assembly Instructions For a 20 kHz System

Table 4.22 Assembly Instructions For a 20 kHz System

Step	Action
1	Clean the mating surfaces of the converter, booster, and horn. Remove any foreign material from the threaded holes.
2	Install the threaded stud into the top of the booster. Torque to 450 in·lbs, 50.9 N·m. If the stud is dry, apply 1 or 2 drops of a light lubricant oil before installing (if required).
3	Install the threaded stud into the top of the horn. Torque to 450 in·lbs, 50.9 N·m. If the stud is dry, apply 1 or 2 drops of a light lubricating oil before installing (if required).
4	Install a single Mylar washer (matching the size of the washer to the stud) to each interface.
5	Assemble the converter to the booster and the booster to the horn.
6	Torque to 220 in·lbs, 24.9 N·m.

4.10.4.2 Assembly Instructions For a 30 kHz System

Table 4.23 Assembly Instructions For a 30 kHz System

Step	Action
1	Clean the mating surfaces of the converter, booster, and horn. Remove any foreign material from the threaded holes.
2	Install the threaded stud into the top of the booster; torque to 290 in·lbs, 32.8 N·m.
3	Install the threaded stud into the top of the horn; torque to 290 in·lbs, 32.8 N·m.
4	Install a single Mylar washer (matching the size of the washer to the stud) to each interface.
5	Screw the converter onto the booster, and the booster to the horn.
6	Torque to 185 in·lbs, 20.9 N·m.

4.10.4.3 Assembly Instructions For a 40 kHz System

Table 4.24 Assembly Instructions For a 40 kHz System

Step	Action
1	Clean the mating surfaces of the converter, booster, and horn. Remove any foreign material from the threaded holes.
2	Apply a drop of Loctite® 290 (or equivalent) to the studs for the booster and horn.
3	Install the threaded stud into the top of the booster; torque to 70 in·lbs, 7.9 N·m, and let cure for 30 minutes.
4	Install the threaded stud into the top of the horn; torque to 70 in·lbs, 7.9 N·m, and let cure for 30 minutes.
5	Coat each interface with a thin film of silicone grease - <i>but do not apply silicon grease to a threaded stud or tip.</i>
6	Screw the converter to the booster.
7	Torque to 95 in·lbs, 10.7 N·m.
8	Slide the booster/horn assembly into the adapter sleeve, see Figure 4.15 . Screw on the adapter sleeve ring nut and leave loose.
9	Screw the booster into the horn.
10	Repeat step 7.
11	Securely tighten the adapter sleeve ring nut with the adjustable face spanner wrench shipped with the sleeve assembly.

4.10.5 Assembling the Acoustic Stack

Figure 4.14 Assembling the Acoustic Stack

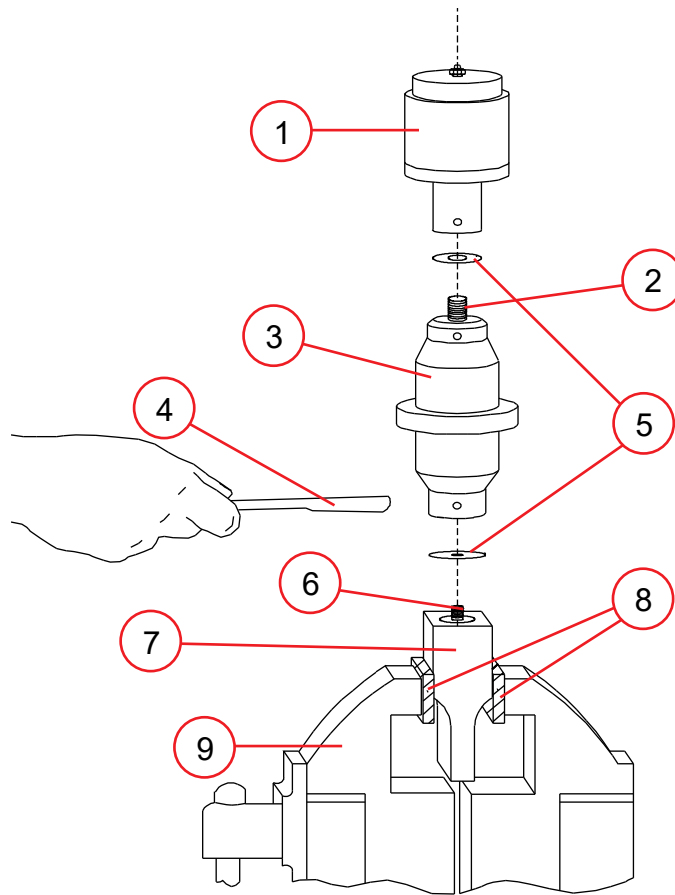

*Shown with rectangular horn secured in the vise

Table 4.25 Assembling the Acoustic Stack

Item	Description	Item	Description
1	Converter	6	Horn stud
2	Booster stud	7	Horn
3	Booster	8	Vise jaw protectors
4	Spanner	9	Vise

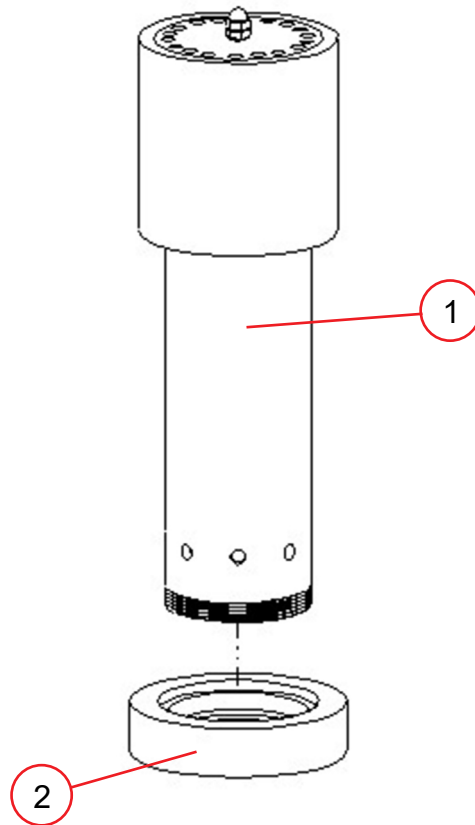
Figure 4.15 Sleeve Assembly**Table 4.26** Sleeve assembly

Item	Description
1	Sleeve assembly
2	Ring nut
N/A	Adjustable face spanner (not shown)

4.10.5.1 Universal 20 kHz Stack Vise

The 20 kHz Universal Stack Vise is used for the separation, assembly, and torquing of 20 kHz stacks. The Vise features three openings (1 1/2", 1 5/8" and 2") to fit most horns, boosters, and converters. The stack vise is made of aluminum to prevent marking on both the aluminum and titanium horns, boosters, and converters. It has bolt holes for permanent mounting on a bench top, or it can be simply clamped to a table top. This stack vise is to be used in conjunction with torque kits.

Figure 4.16 20 kHz Universal Stack Vise, EDP 100-063-642

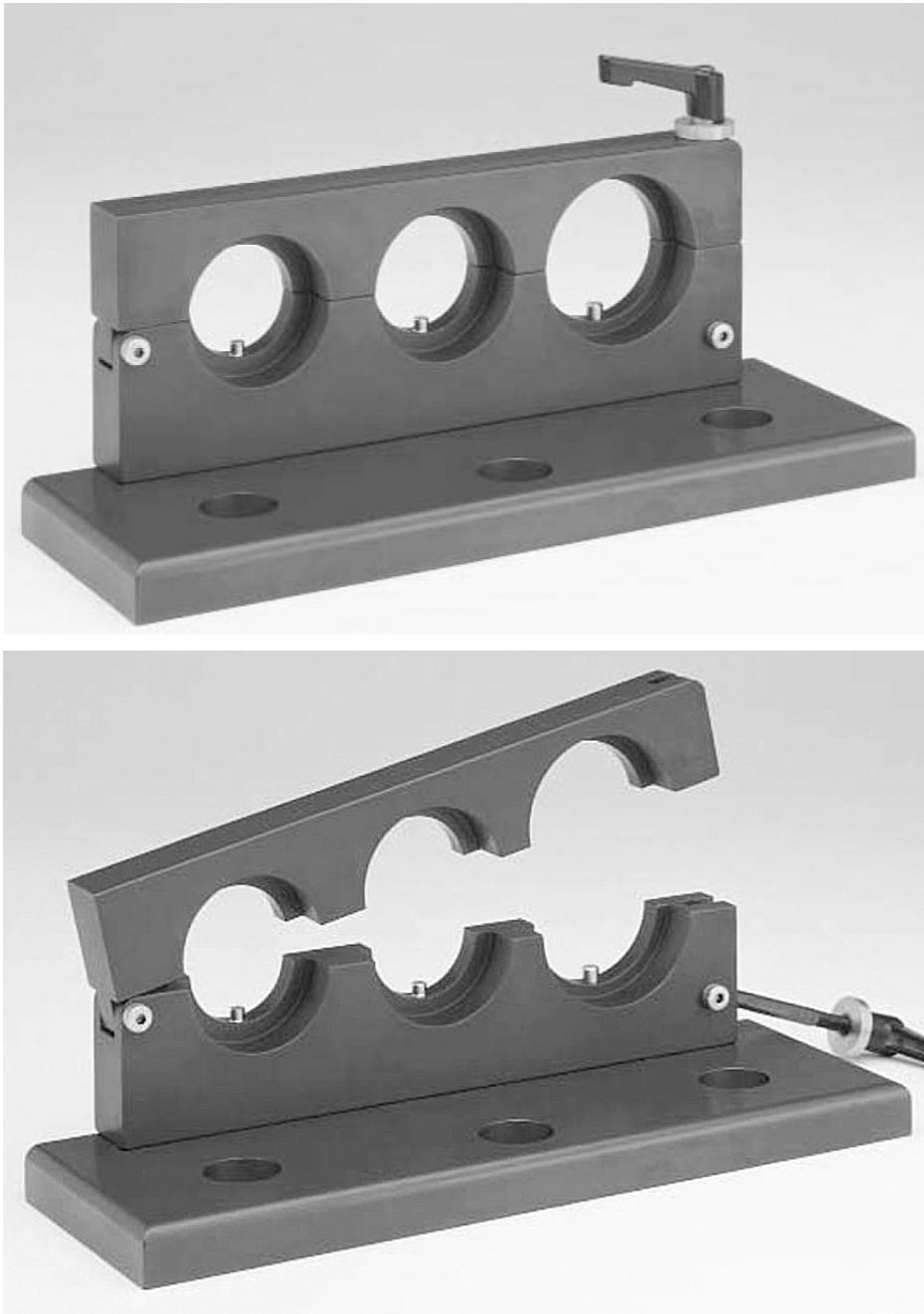

4.10.5.2 Procedure to replace a stud from a horn or booster

Table 4.27 Mounting the Stand

Step	Action
1	Remove the studs from the horn or booster.
2	Before reinserting a stud which has been used in an aluminum horn or booster, use a file or wire brush to clean the aluminum bits from the knurled end of the stud. Also clean the threaded hole using a clean cloth or towel. Replace studs used in titanium horns. Studs tightened in titanium horns experience damage to the knurled end preventing satisfactory locking when reused. Studs used in titanium horns should be disposed of and a new one used. Do not apply grease to the new threaded stud.
3	Using a torque wrench, tighten the stud at the torque specification shown in section 4.10.6.1 Stud for Horns . Failure to follow these torque specifications may result in the horn/booster stud loosening, stud breakage, and unexplained overloads.

4.10.6 Stack Assembly Torque

NOTICE	
	<p>The use of a Branson torque wrench or the equivalent is recommended. EDP 101-063-787 for 20 and 30 kHz systems, and EDP 101-063-618 for 40 kHz systems.</p>

4.10.6.1 Stud for Horns

Table 4.28 Torque values

Stud Size	EDP#	Frequency	Horn Material	Torque
3/8"-24 x 1"	100-098-120	20 kHz	Ti	33 N·m, 290 in·lbs
3/8"-24 x 1-1/4"	100-098-121		Al, Steel	33 N·m, 290 in·lbs
1/2"-20 x 1-1/4"	100-098-370		Ti, Steel	51 N·m, 450 in·lbs
1/2"-20 x 1-1/2"	100-098-123		Al	51 N·m, 450 in·lbs
3/8"-24 x 1"	100-298-170	30 kHz	Al, Ti, Steel	33 N·m, 290 in·lbs
M8-1.25mm	100-098-790	40 kHz	Al, Ti, Steel	8 N·m, 70 in·lbs

Table 4.29 Studs for Boosters

Stud	EDP#	Frequency	Torque
1/2"-20 x 1-1/2"	100-098-123	20 kHz	51 N·m, 450 in·lbs
3/8"-24 x 1	100-298-170	30 kHz	33 N·m, 290 in·lbs
M8-1.25 mm*	100-098-790	40 kHz	8 N·m, 70 in·lbs

*Add a drop of Loctite 290 to the stud, torque, and let cure for 30 minutes before use.

4.10.6.2 Connecting Tip to Horn

Table 4.30 Mounting the Stand

Step	Action
1	Clean the mating surfaces of the horn and tip. Remove foreign matter from the threaded stud and hole
2	Hand assemble the tip to the horn. Assemble dry. Do not use any silicone grease
3	Use the spanner wrench and an open-end wrench (refer to Figure 4.17 below) and tighten to the specifications in Table 4.31 Tip to Horn Torque Specification

Figure 4.17 Connecting Tip to Horn

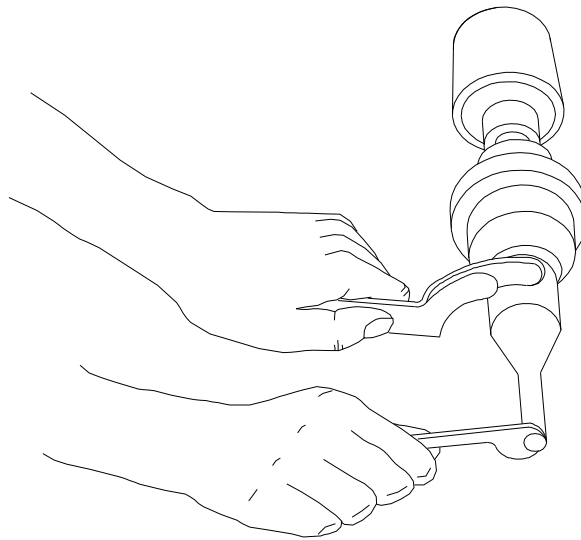

4.10.6.3 Tip to Horn Torque Specifications

Table 4.31 Tip to Horn Torque Specification

Tip Thread	Torque
1/4"-28	12 N·m, 110 in·lbs
3/8"-24	20 N·m, 180 in·lbs

4.10.6.4 Stud Washers

Table 4.32 Stud Washers - 20 kHz

Description	EDP	Torque
3/8"-24 to 3/8"-24	109-116-1224	33 N·m, 290 in·lbs
3/8"-24 to 1/2"-20	109-116-1334	51 N·m, 450 in·lbs
1/2"-20 to 3/8"-24	109-116-1225	33 N·m, 290 in·lbs
1/2"-20 to 1/2"-20	109-116-1124	51 N·m, 450 in·lbs

Table 4.33 Stud Washers - 40 kHz

Description	EDP	Torque
M8 to M8	109-116-1215	8 N·m, 70 in·lbs
M8 x 1.25 to 3/8"-24	109-116-1425	33 N·m, 290 in·lbs

Table 4.34 Step Studs for Horns*

Stud Booster Side/ Horn Side	EDP	For	Torque
3/8"-24 to 1/2"-20"	100-098-395	Titanium horns with 1/2"-20 threads	51 N·m, 450 in·lbs
3/8"-24 to 1/2"-20"	100-098-394	Aluminum horns with 1/2"-20 threads	51 N·m, 450 in·lbs
1/2"-20 to 3/8"-24	100-098-249	Titanium horns with 3/8"-24 threads	33 N·m, 290 in·lbs
1/2"-20 to 3/8"-24	100-098-363	Aluminum horns with 3/8"-24 threads	33 N·m, 290 in·lbs

*Step studs should only be used in prototype applications, NOT production.

4.10.6.5 Follow Up Notes

- Mylar washers are not available for 40 kHz systems
- Always use Mylar washer between the booster and the horn surface. Do not use Mylar between stud washer and horn. Do not use a Mylar washer between stud washer and booster
- These torque specifications do not apply to 15 kHz composite horns

4.11 Installing the Ultrasonic Stack in the Actuator

Table 4.35 Installing the ultrasonic stack in the actuator

Step	Action
1	Make sure that the system power is turned off by disconnecting the power plugs.
2	Pull the magnetic cover towards you to remove it.
3	Open the carriage latch with a 5 mm hex wrench.
4	Loosen the two converter cover screws (labeled as <i>Cover Only</i>) with a 5 mm hex wrench.
5	Pull the carriage door straight off and set it aside.
6	Take the assembled ultrasonic stack and align the ring on the booster just above the support washer in the carriage. Firmly push the stack into place, with the acorn nut on the top of the converter making contact with the contactor in the top of the carriage.
7	Reinstall the carriage door and close the carriage latch.
8	Align the stack by rotating it, if necessary.
9	Reinstall the actuator cover.

Figure 4.18 Installing the ultrasonic stack in the actuator

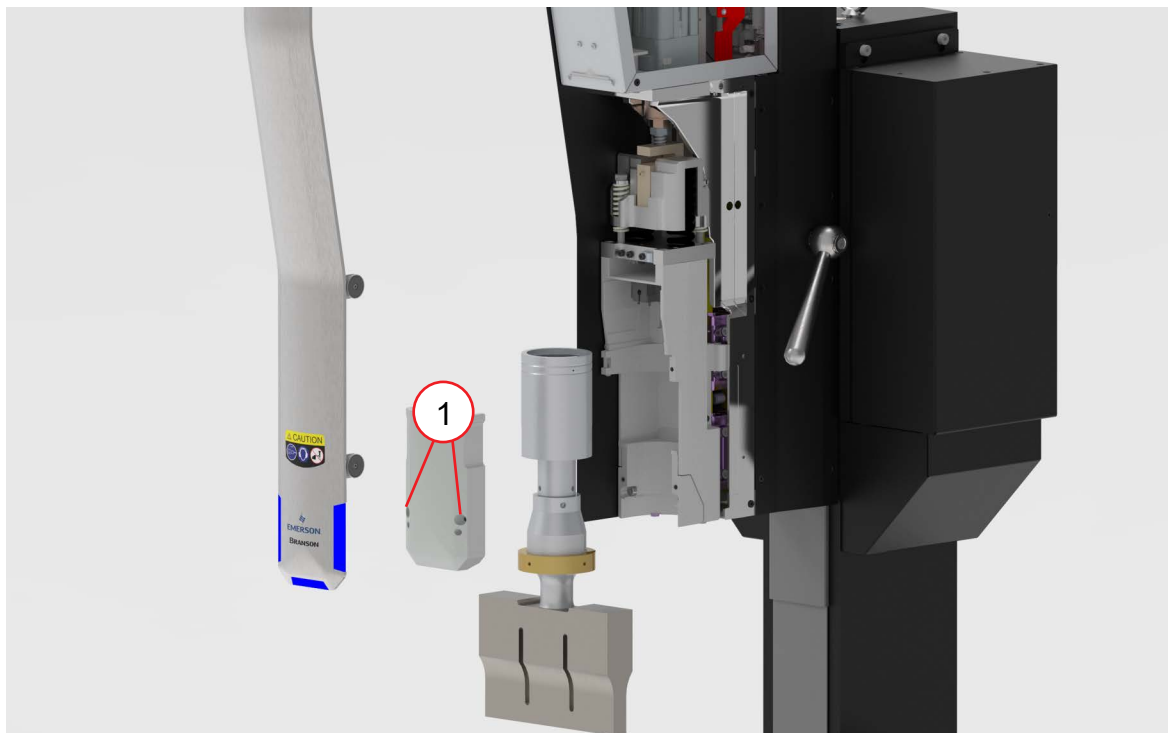

Table 4.36 Screws

Item	Description
1	Converter cover screws (Cover Only)

4.11.1 Quick Ultrasonic Stack Change

The ultrasonic stack and converter support can be removed together from the actuator to retain the stack alignment to your welding fixture. This enables quick tooling changeovers.

Table 4.37 Quick ultrasonic stack change

Step	Action
1	Make sure that the system power is turned off by disconnecting the power plugs.
2	Pull the magnetic cover towards you to remove it.
3	Open the carriage latch with a 5 mm hex wrench.
4	Loosen the two converter support screws (labeled as <i>Full Assy</i>) with a 5 mm hex wrench.
5	Pull the ultrasonic stack and converter support straight off and store it for future uses.

Figure 4.19 Quick ultrasonic stack change

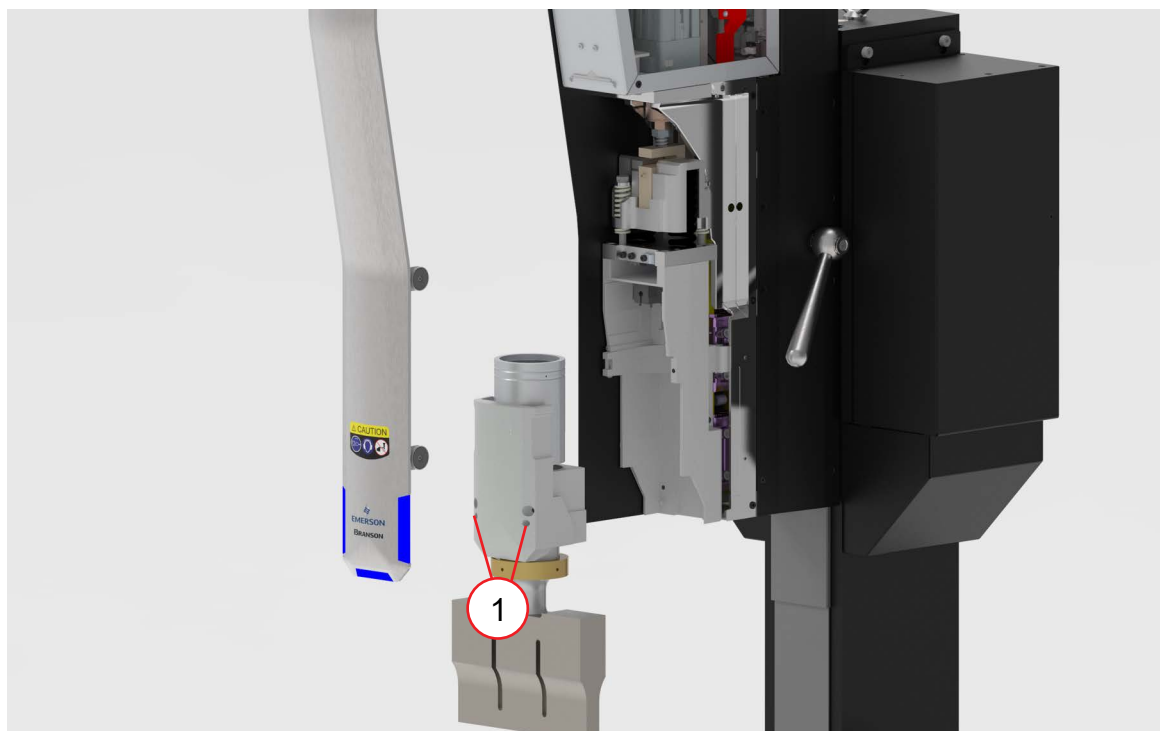

Table 4.38 Screws

Item	Description
1	Converter support screws (Full Assy)

4.12 Mounting the Fixture on the Base

The base provides mounting holes for your fixture. Mounting holes are also provided for the optional Branson leveling plate kit. The base is tapped for metric M10-1.5 hardware. The mounting holes are arranged in three concentric bolt circles with the following dimensions.

CAUTION	
	The base is cast metal and the mounting holes can become stripped if the hardware is overtightened. Tighten your hardware only enough to prevent movement of your fixture.

Figure 4.20 Mounting Holes on Base



4.13 Adjusting Welder Height and Aligning the Horn

For maximum welding efficiency, position the welder so that the distance between the workpiece and the horn is at a minimum; however leave enough room to allow for easy removal of the workpiece from the fixture.

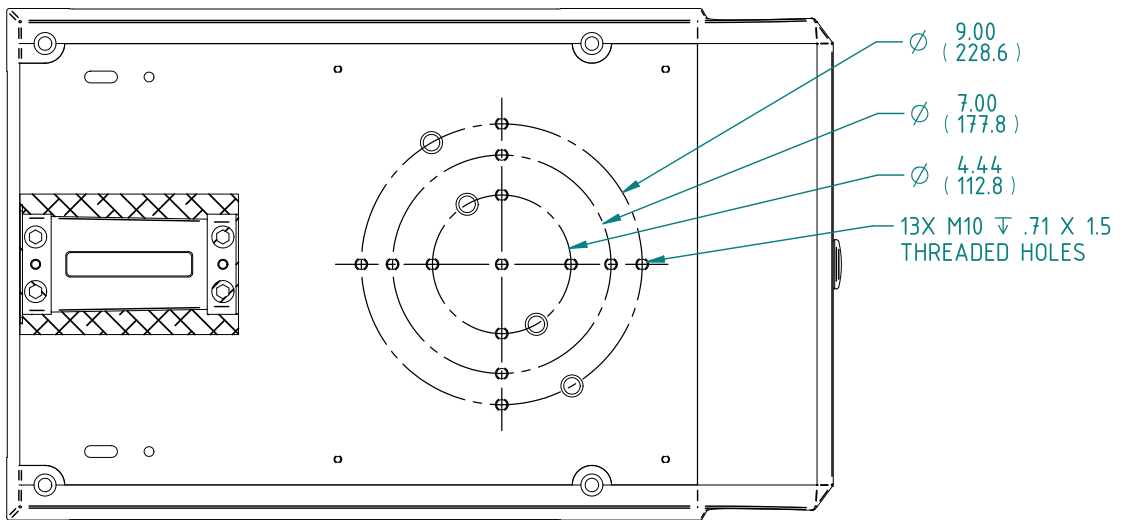
Table 4.39 Adjusting Welder Height and Aligning the Horn

Step	Action
1	Position the fixture loosely on the work surface.
2	Fit a test part onto the fixture.

3 On the HMI, press the button on the top right corner to open the **Action Center**. Press the **Actuator Setup** button.

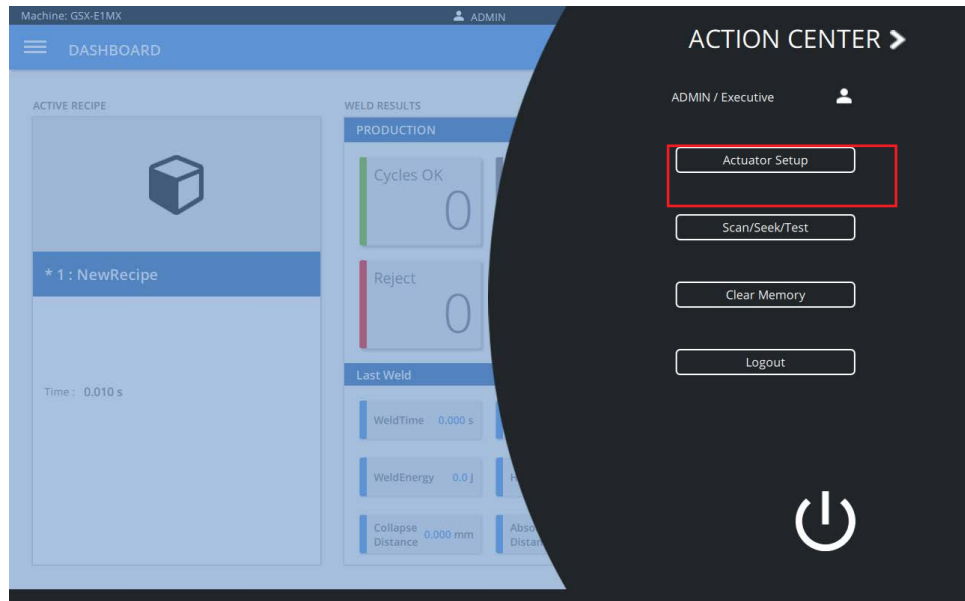

4 On the Actuator Setup screen, select **Find Part Contact**. Press the start switches to perform a Find Part Contact.

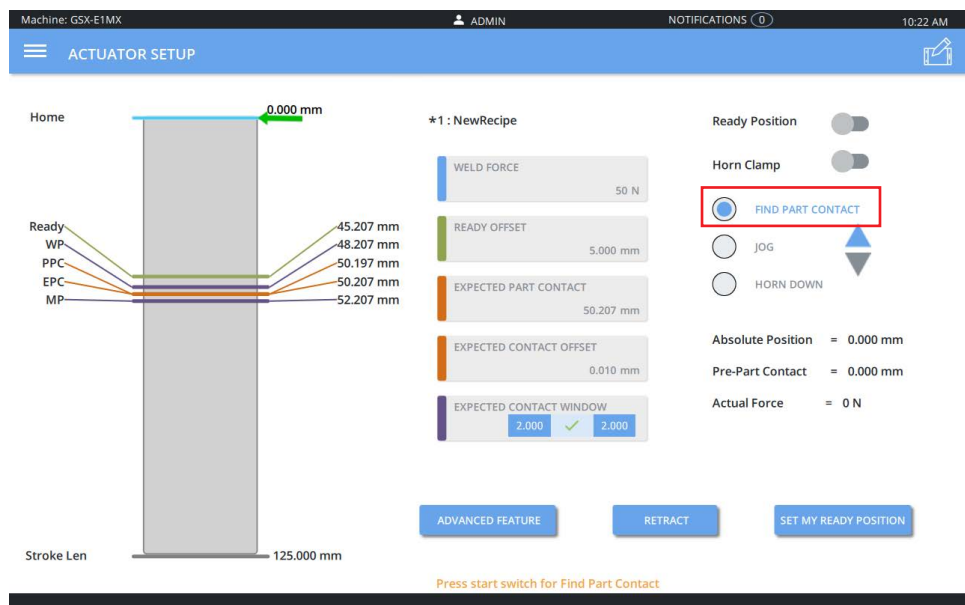

Table 4.39 Adjusting Welder Height and Aligning the Horn

Step	Action
5	<p>On the Actuator Setup screen, select Horn Down. Set the Weld Force to the minimum (5 N). Press and hold the start switches. The horn will descend to the fixture on the base of the actuator without applying ultrasonic energy. Verify that the fixture is properly aligned with the horn.</p> <p>NOTICE The horn will only stay down as long as the start switches are held on.</p> 
6	<p>If misaligned, turn on the Horn Clamp option; this will cause the horn to remain at the workpiece when the start switches are released. Set the Weld Force to the minimum (25 N). Press the start switches. The horn will descend to the fixture on the base of the actuator without applying ultrasonic energy. Release the start switches.</p> <p>With the horn clamped in place and lightly touching the part, align the fixture with the horn.</p> 
7	<p>Once the fixture is aligned with the horn, press the Retract button to release.</p>
8	<p>Increase the Weld Force to 250 N and perform a Horn Down (with Horn Clamp set to on). Lock the fixture into place to complete the alignment.</p>

4.14 Converter Cooling

Converter performance and reliability can be adversely affected if the converter ceramics are subjected to temperatures above +60°C (+140°F). The converter front driver temperature should not exceed 50°C (122°F).

To prolong converter life and maintain a high degree of system reliability, the converter should be cooled with clean, dry, compressed air, particularly if your application calls for continuous ultrasonic operation. Converter cooling is especially critical in 40 kHz applications.

Use one of the following procedures to determine if a converter is operating close to the maximum allowable temperature. Check converter temperature immediately after substantial machine operation and without power applied to the horn.

- Press a pyrometer probe (or similar temperature measuring device) against the front driver of the converter assembly. Wait for the probe to reach the temperature of the shell. If the temperature is 120 °F (49 °C) or higher, the converter requires a cooling air stream
- If a temperature measuring device is unavailable, use your hand to feel the shell of the converter. If the converter is hot to touch, the converter requires a cooling air stream

High duty cycles require additional cooling for the converter. System average power must be limited to the specified continuous maximum. Higher peak power, up to the maximum acceptable power limit, with an on time of up to 10 seconds may be obtained, if appropriate off time ensures that, on average, the continuous duty maximum power is not exceeded.

Figure 4.21 Air Inlet

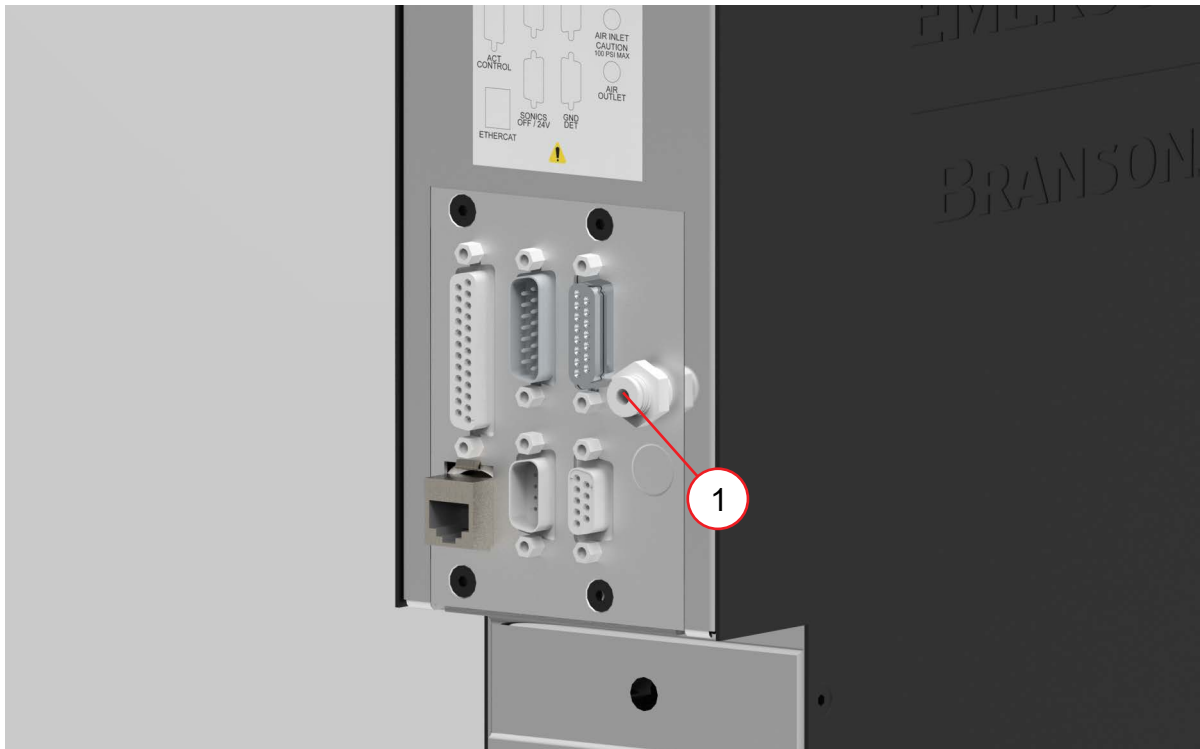

Table 4.40 Air Inlet

Item	Description
1	Air Inlet

Table 4.41 Continuous Duty Maximum Power - Power Supply

Model	Power	Continuous Duty Max. Power	Full Power Duty Cycle
20 kHz	1250 W	800 W	10 seconds on, 10 seconds off (50% duty cycle)
	2500 W	1600 W	10 seconds on, 10 seconds off (50% duty cycle)
	4000 W	2000 W	5 seconds on, 15 seconds off (25% duty cycle)
30 kHz	1500 W	800 W	2 seconds on, 2 seconds off (50% duty cycle)
40 kHz	800 W	400 W	10 seconds on, 10 seconds off (50% duty cycle)

If converter cooling is required, use the following steps:

Table 4.42 Converter Cooling Procedure

Step	Action
1	Start with a 50 psi (345 kPa) air source or higher from a 1.5 mm (0.06 in) I.D. orifice.
2	Perform a run of welding operations.
3	Immediately after completing the welding run, check the converter temperature.
4	If the converter is still too hot, increase the diameter of the orifice in small increments until the temperature falls within the ranges in the chart.

4.15 LED Lamp

Built-in LED lamp provides illumination with ease to work surfaces. Light will turn on automatically on system start-up.

Figure 4.22 LED Lamp

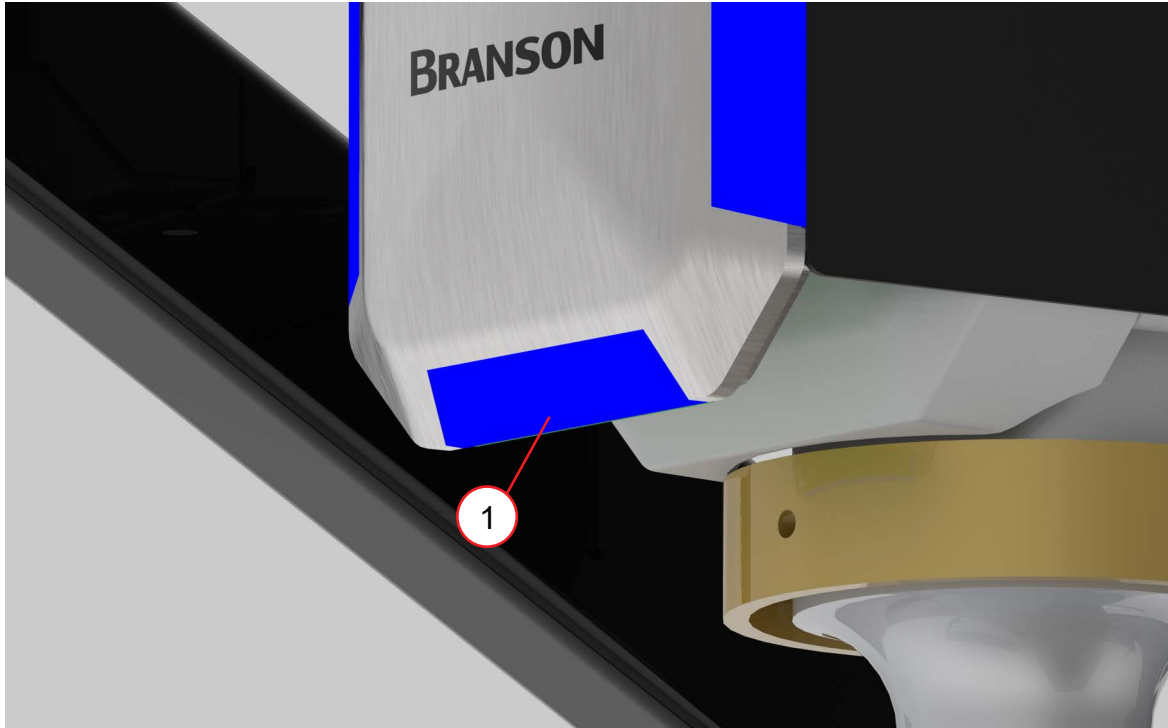

Table 4.43 LED Lamp Location

Item	Description
1	LED Lamp

4.16 USB Accessories

USB (Universal Serial Bus) is a plug-and-play interface that allows the GSX-E1 system to communicate with keyboards and mice.

The GSX-E1 system is equipped with two USB ports located on the touchscreen.

Figure 4.23 USB Ports

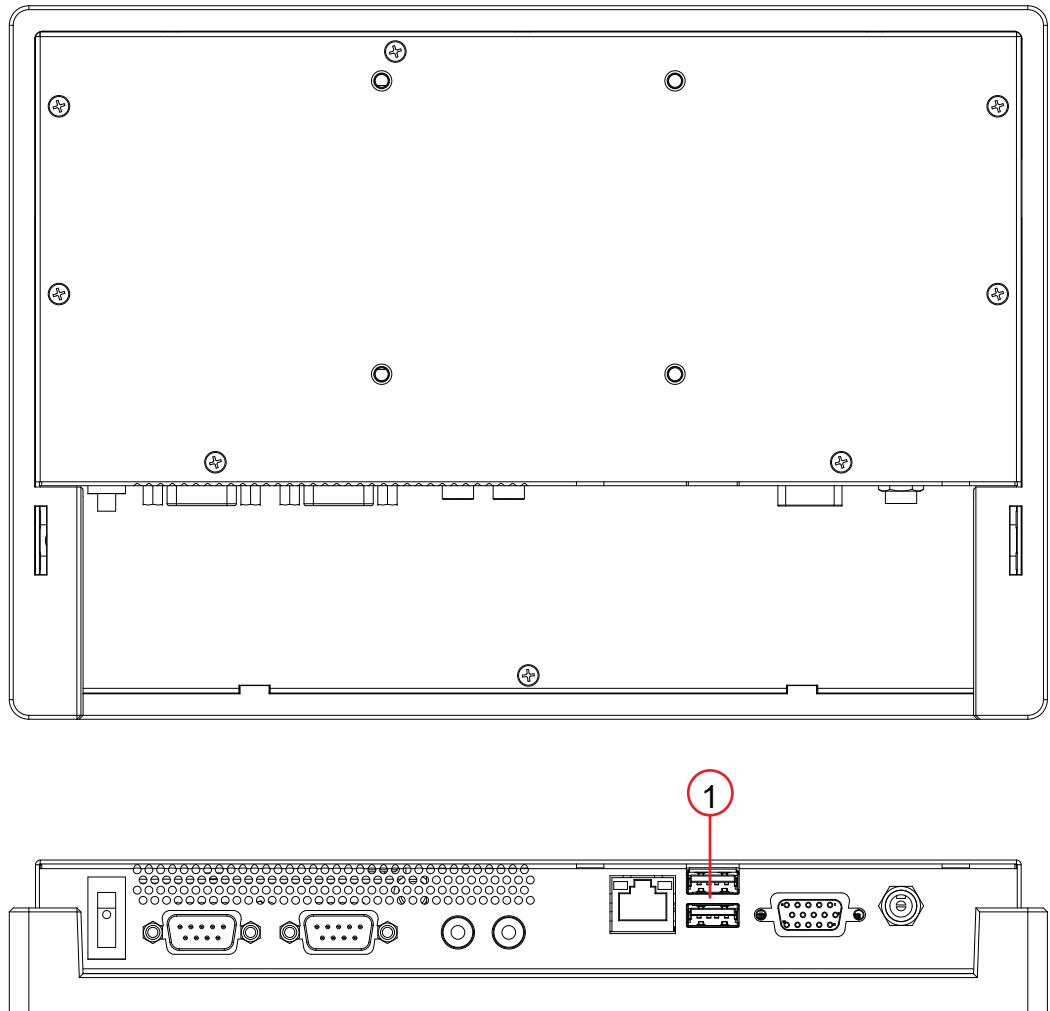

Table 4.44 USB Ports

Item	Description
1	USB 2.0/USB 3.0 Ports

NOTICE



USB ports on the HMI are for keyboards and mice only. Do not use any other kind of device into these ports.

4.17 Barcode Scanner

The GSX-E1 system supports USB barcode scanners. The barcode scanner must have a keyboard emulation mode. The barcode scanner can be used to recall recipes and enter the Part ID by scanning 1D linear barcodes (such as UPC and EAN codes) & 2D barcodes (such as QR and Data Matrix codes). See section [5.10.1.1 General](#) for more information.

A Datalogic Gryphon I GD44XX barcode scanner is recommended for proper operation.

Figure 4.24 Barcode scanner, 1D linear barcode & 2D barcode example



NOTICE	
	Barcode scanner must be connected to the USB port located on the power supply.

Figure 4.25 Power Supply - USB port on the GSX-E1 system



Table 4.45 Power Supply - USB port on the GSX-E1 system

Item	Description
1	USB 2.0/USB 3.0 Port

Figure 4.26 Power Supply - USB port on the GSX-E1 EtherNet/IP system



Table 4.46 Power Supply - USB port on the GSX-E1 EtherNet/IP system

Item	Description
1	USB 2.0/USB 3.0 Port

4.18 Password Recovery Kit

In the event an Executive level user cannot log into the system, the Password Recovery Kit can be used to recover the Executive user's password and ID. The Password Recovery Kit is a dongle that plugs into the User I/O connector on the power supply. It can be ordered from Branson. EDP number is 1016041.

Table 4.47 Password Recovery Kit Instructions

Step	Action
1	Power down the GSX-E1 power supply.
2	Plug the PRK into the User I/O connector located on the power supply.
3	Power up the GSX-E1 power supply.
4	Authority check will still be set to Yes, but current user with Password Recovery Kit will be able to bypass the login screen (not restricted by authority levels or passwords).
5	Navigate to the System Configuration/User Management section to Enable an user Executive account and view the user ID and password.
6	After user ID and password is recovered, unplug the Password Recovery Kit and power down the power supply.
7	Power up the GSX-E1 power supply for normal login and usage.

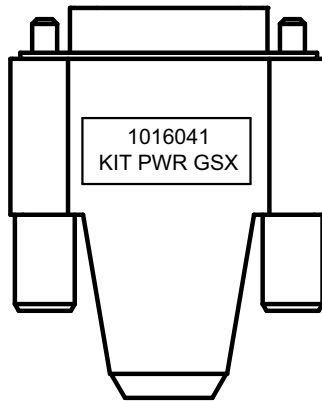

Figure 4.27 Password Recovery Kit (EDP 1016041)



Chapter 5: Operation

5.1	GSX-E1 System Power On and Login	100
5.2	Screen Layout	102
5.3	Date & Time	103
5.4	Setting Up An Application	104
5.5	Main Menu & Action Center	107
5.6	Dashboard	109
5.7	Recipes	113
5.8	Production	127
5.9	Analytics	128
5.10	System	130
5.11	Actuator Setup.	159
5.12	Scan/Seek/Test.	161
5.13	Optional Dynamic Weld Mode	164

5.1 GSX-E1 System Power On and Login

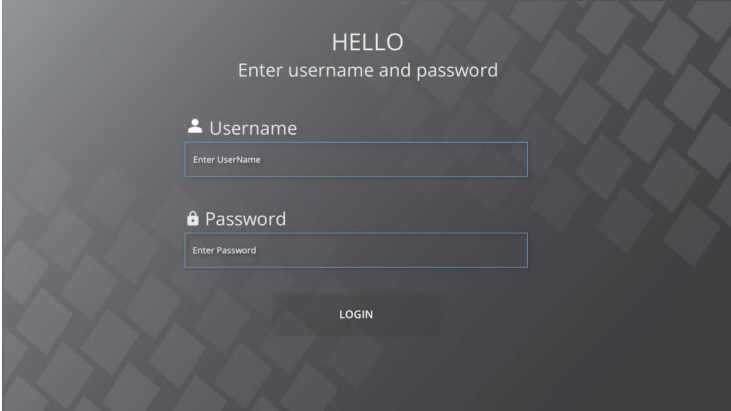
Step	Action
1	<p>Press the power button to turn on the system.</p> <p>Figure 5.1 Power button on the GSX-E1 system</p>  <p>Figure 5.2 Power button on the GSX-E1 EtherNet/IP system</p> 
2	<p>Log in with the default username and password. The GSX-E1 system is shipped with the following credentials:</p> <ul style="list-style-type: none"> • Username: ADMIN • Password: 123456Aa# 

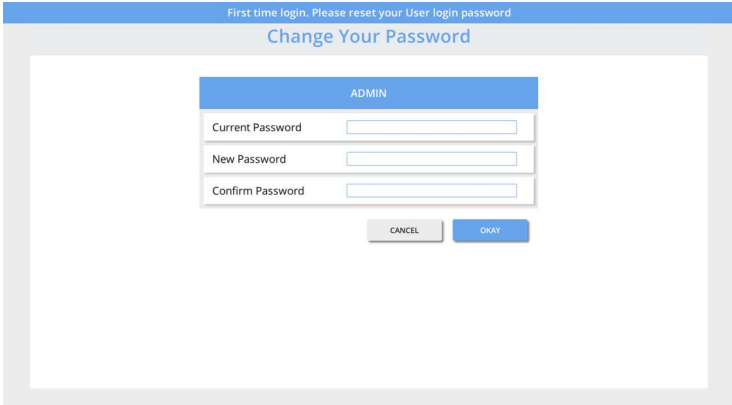
Step	Action
3	<p>At first time log in, a new password must be created. Enter the default password, and then enter and confirm the new password.</p> 

5.2 Screen Layout

Figure 5.3 Screen Layout

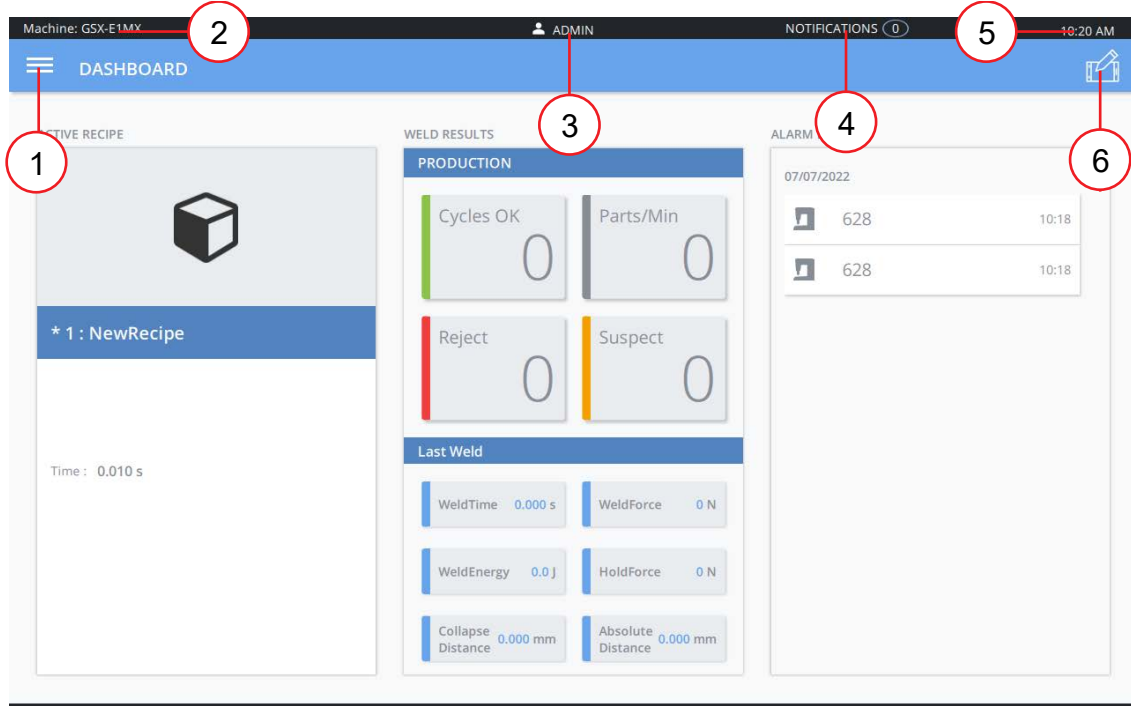

Item	Description
1	Main Menu Button Press the main menu button on the top left corner to open the Main Menu.
2	Machine Name Displays the assigned machine name. See section 5.10.1.1 General to change the assigned name.
3	Current User Displays the current user logged in.
4	Notifications Notifications alert you to the arrival of alarms and events.
5	Time Displays the current time.
6	Action Center Button Press the button on the top right corner to open the Action Center.

5.3 Date & Time

The GSX-E1 system provides each cycle with a time and date stamp for production and quality control purposes.

Table 5.1 Date & Time

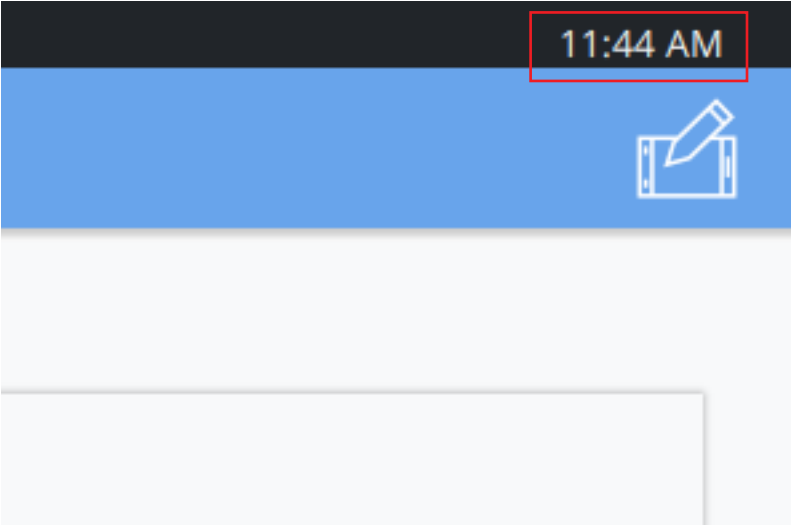
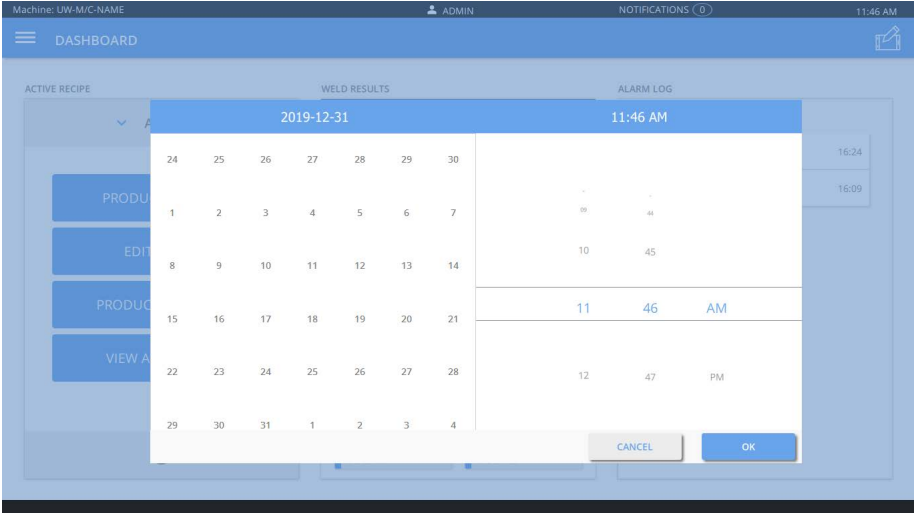
Step	Action
1	<p>Press the clock on the upper-right section of the screen.</p> 
2	<p>Select the current date & time. Press OK to confirm.</p> 

5.4 Setting Up An Application

Table 5.2 Setting up an application



Step	Action
1	Make sure that the system power is turned off by disconnecting the power plugs.
2	Install the ultrasonic stack in the actuator. See section 4.11 Installing the Ultrasonic Stack in the Actuator for detailed information. 
3	Position the fixture loosely on the base. See section 4.12 Mounting the Fixture on the Base for detailed information. 
4	Place the part to be welded in the fixture.
5	Turn on the GSX-E1 system.
6	Unlock the actuator from the actuator support by rotating the column clamp. 

Table 5.2 Setting up an application

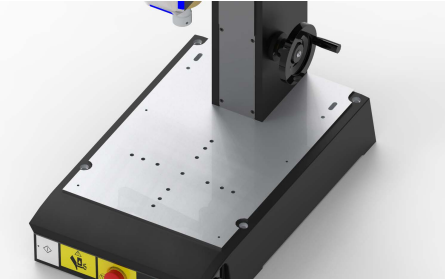

Step	Action
7	<p>Move the actuator down using the elevation hand crank until it touches the part and applies a small force on it.</p> 
8	<p>Loosen the carriage door screws, rotate the stack and adjust the fixture until the horn is properly aligned with the part. Tighten the carriage door screws and lock down the fixture.</p>
9	<p>Use the elevation hand crank to adjust the height of the welder for the desired stroke length. For proper triggering, provide a minimum stroke length of 5 mm. Then tighten the column clamp.</p>
10	<p>Create a recipe (see section 5.7 Recipes for more information). After creating the recipe, open the Action Center and select Actuator Setup.</p> 
11	<p>Next step is to find the Part Contact position. The part contact position is based on the distance that the horn has to travel from its home position until it touches the part.</p>
12	<p>In the Actuator Setup screen, select Find Part Contact.</p> 
13	<p>Press the start switches to initiate the Part Contact process.</p>
14	<p>After the process ends, the HMI will display the part contact distance in the Absolute Position field.</p>
15	<p>From the Main Menu, select Recipes.</p> 
16	<p>Create a new recipe or set an existing recipe as active.</p>

Table 5.2 Setting up an application

Step	Action
17	The GSX-E1 system is ready to weld. Press the start switches to activate the welder.

5.5 Main Menu & Action Center

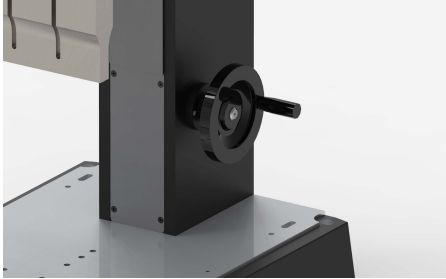
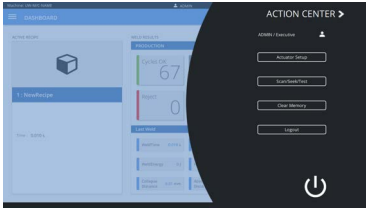
5.5.1 Main Menu

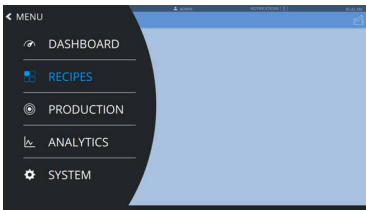
Press the main menu button on the top left corner to open the Main Menu.

Figure 5.4 Main Menu

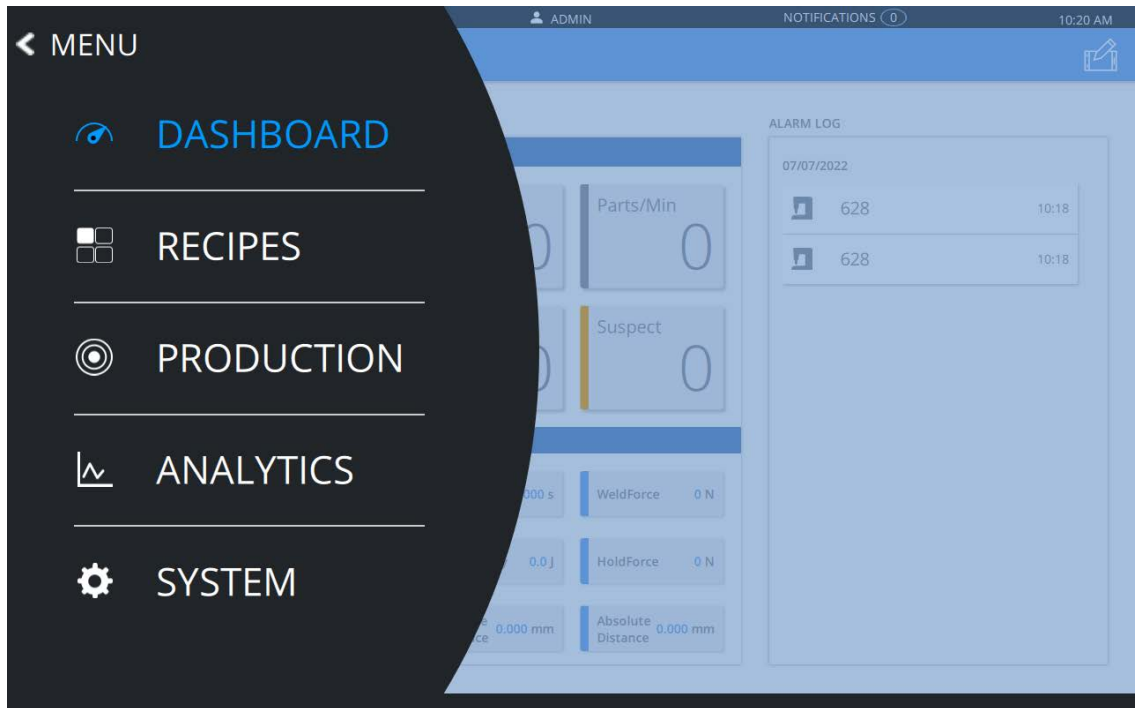

Name	Description
Dashboard	Overview of weld characteristics and statistics.
Recipes	Weld recipe setup, recall, save, and validation.
Production	Production screen.
Analytics	Production screen.
System	Welder system configuration setup.

5.5.2 Action Center

Press the button on the top right corner to open the Action Center.

Figure 5.5 Action Center

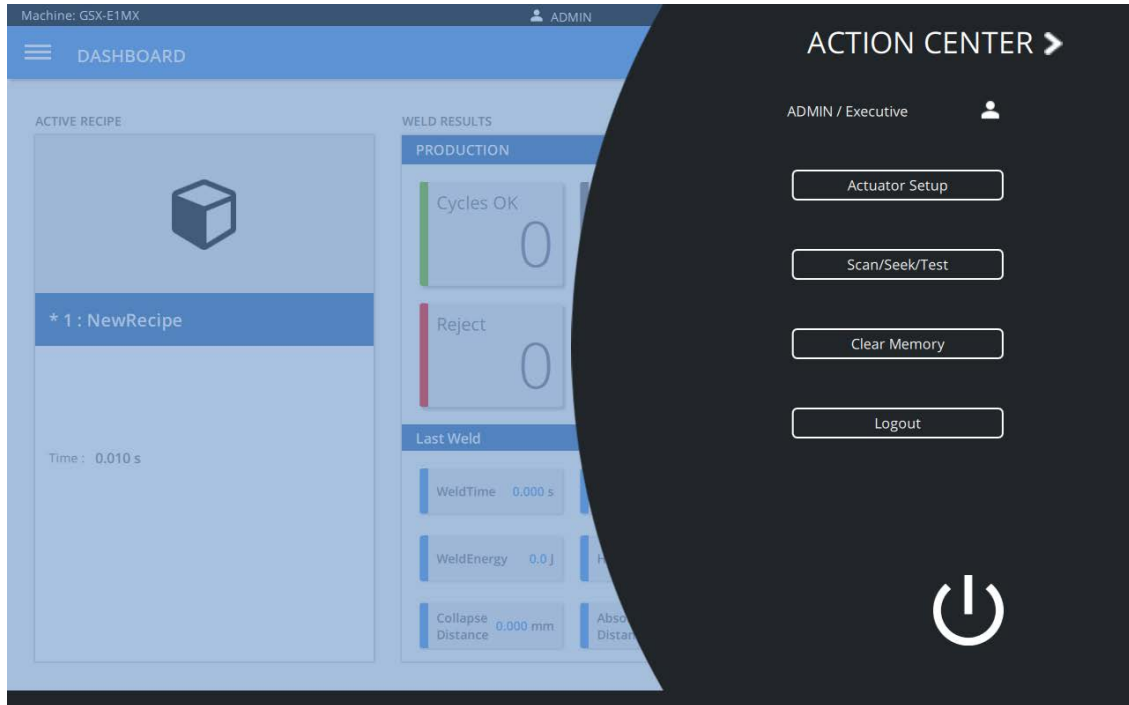

Name	Description
Username/Level	Current user and access level.
Actuator Setup	Press to open the Part Contact/Horn Down menu.
Scan/Seek/Test	Scan, seek, and test stack frequency. Select to tune power supply to ultrasonic stack.
Clear Memory	Centers the power supply start frequency.
Logout	Ends session for current user.

5.6 Dashboard

The Dashboard screen displays any information available from the last completed cycle, including active recipe, weld results and alarm log.

Figure 5.6 Dashboard Screen

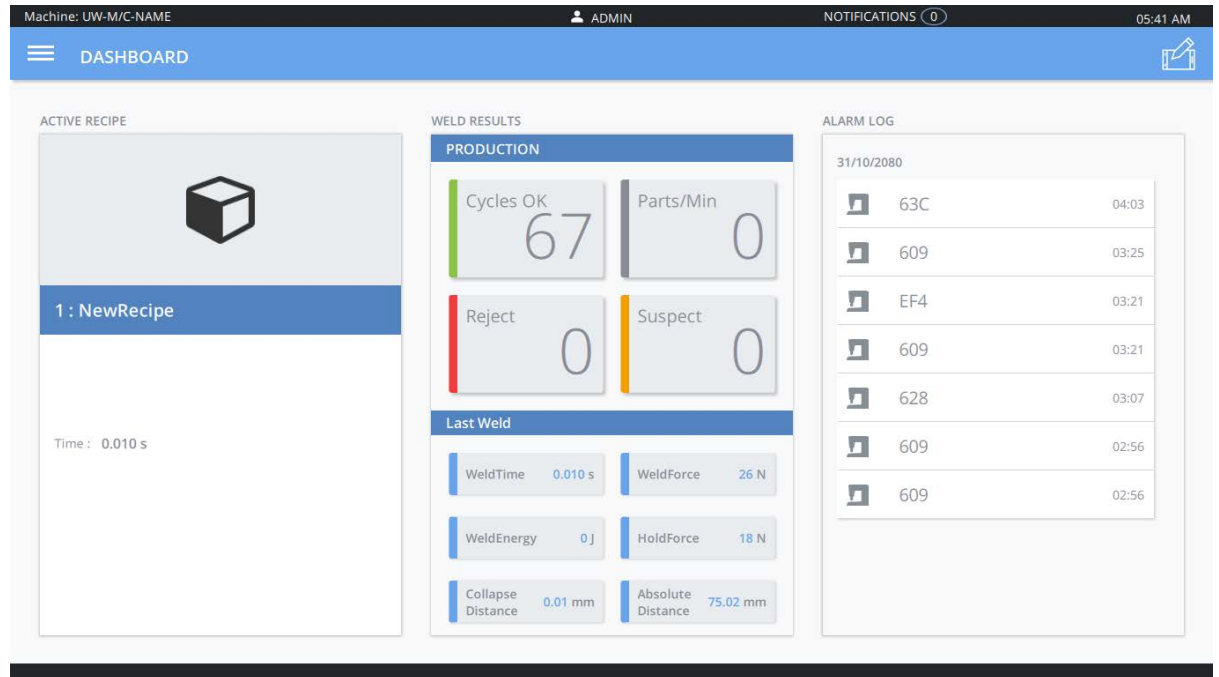

Name	Description
Active Recipe	Displays the current active recipe information.
Weld Results	Displays the current production run, including the number of good welds, parts per minutes, rejected parts and suspect parts. It also displays the weld time, weld force, weld energy, hold force, collapse distance and absolute distance from the last weld.
Alarm Log	Displays the alarm log. Records time, date, alarm number, and cycle number.

5.6.1 Active Recipe Actions Menu

Press the Active Recipe area to show available actions.

Figure 5.7 Active Recipe Actions Menu

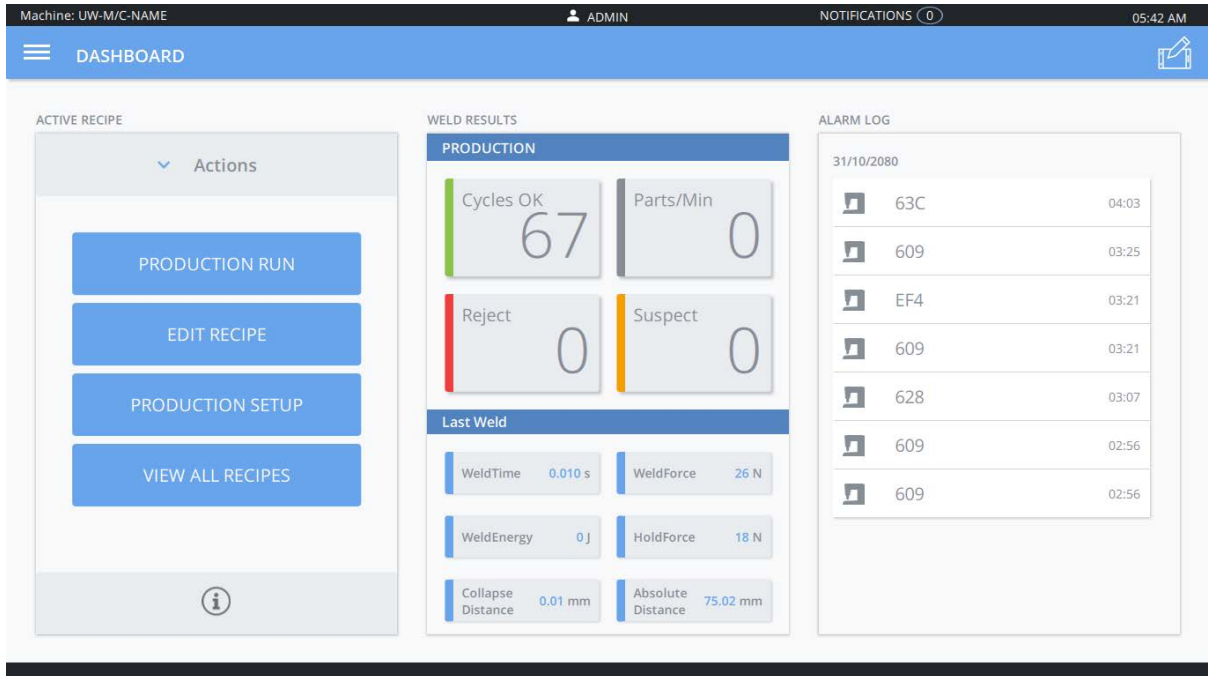

Name	Description
Production Run	Press to open the production run overview screen. See section 5.8 Production for more information.
Edit Recipe	Press to open the active recipe setting screen to allow changes.
Production Setup	Press to open the production setup screen. See section 5.7.9 Production Setup for more information.
View All Recipes	Press to open the recipes main screen.
Recipe Information	Press to display active weld recipe information.

5.6.2 Weld Results Actions Menu

Press the Weld Results area to show available actions.

Figure 5.8 Weld Results Actions Menu

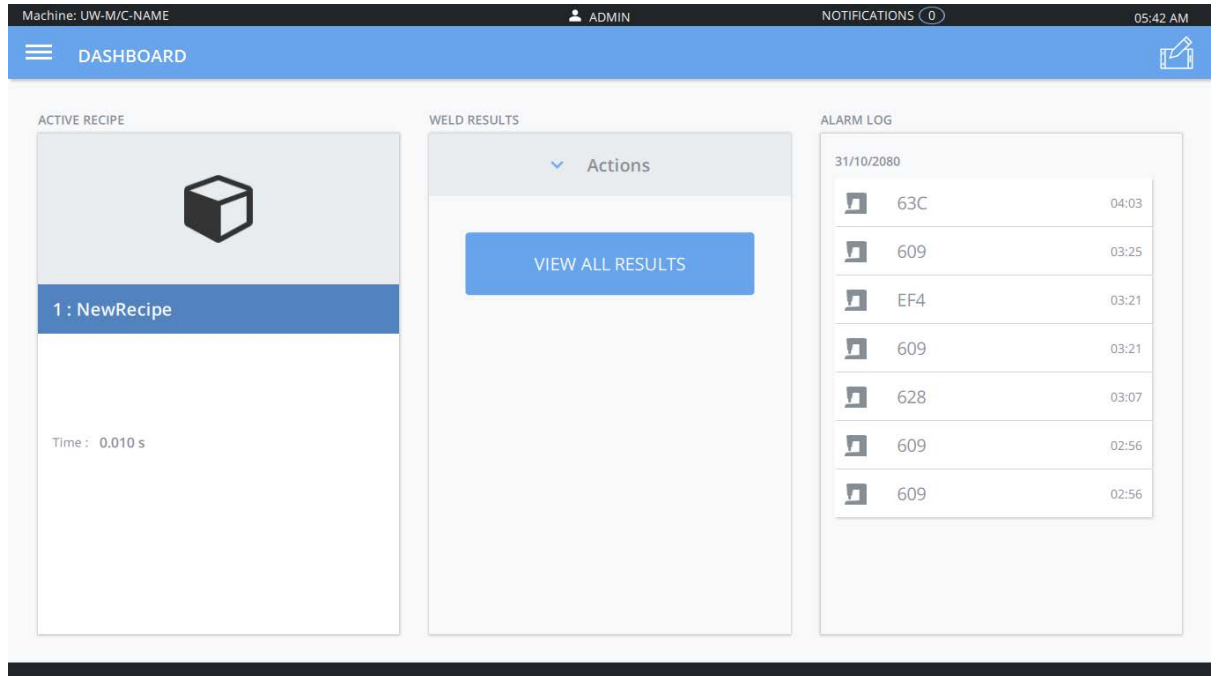

Name	Description
Production Overview	Press to open the production run overview screen. See section 5.8 Production .
View All Results	Press to Display all production run weld results.

5.6.3 Alarm Log Actions Menu

Press the Alarm Log area to show available actions.

Figure 5.9 Alarm Log Actions Menu

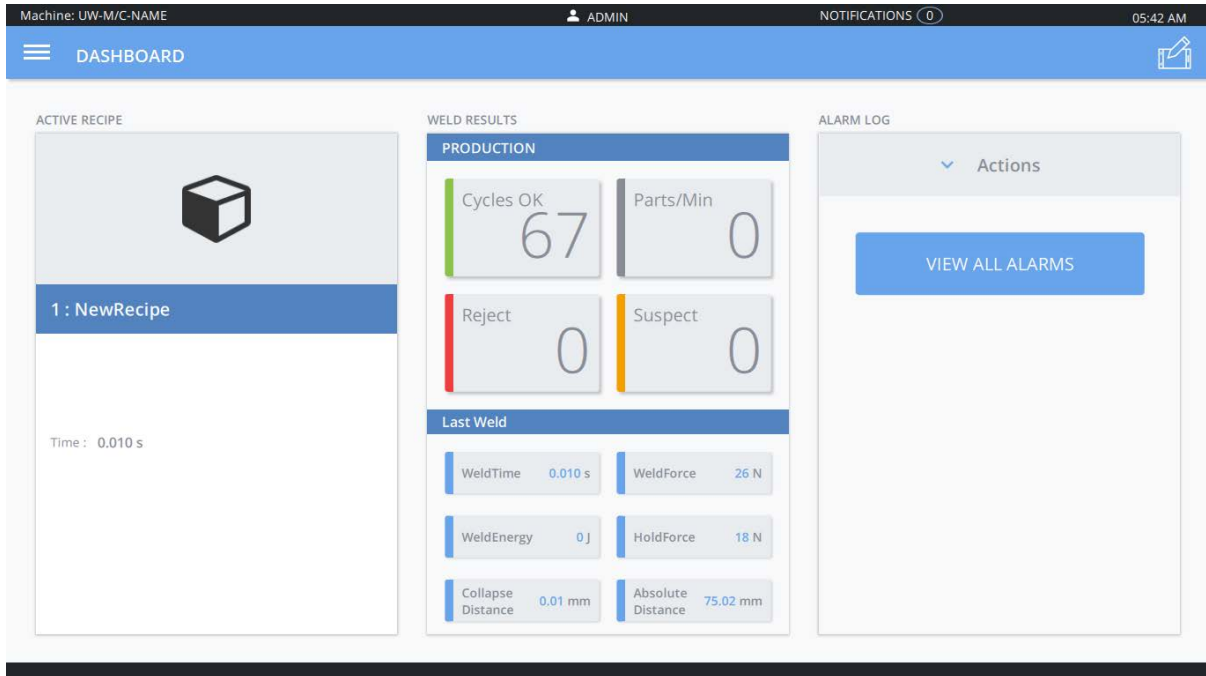

Name	Description
View All Alarms	Displays all production run alarms.

5.7 Recipes

You can set up the GSX-E1 system to weld a particular application and then save the settings to a recipe.

Figure 5.10 Recipes Screen

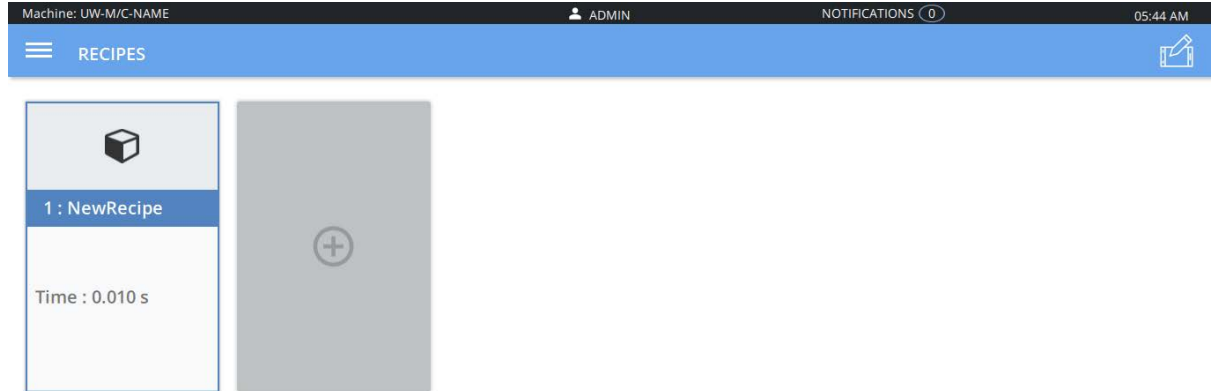

Name	Description
Saved Recipes	Saved recipes are shown for recall, viewing, and modifications.
Active Recipe	The active recipe is highlighted in blue.
Create New Recipe	Press the + button to create a new recipe.

NOTICE	
	An asterisk (*) displayed next to the recipe name means that there are unsaved changes in that specific recipe.

5.7.1 Active Recipe Actions Menu

Figure 5.11 Active Recipe Actions Menu

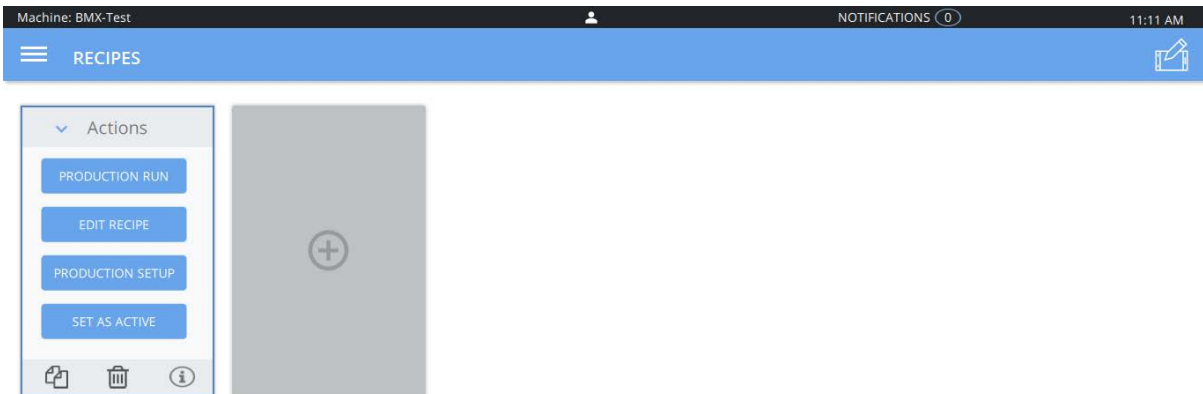

Name	Description
Production Run	Displays production run overview screen. See section 5.8 Production for more information.
Edit Recipe	Opens up active recipe setting screen to allow changes.
Production Setup	Opens up production setup screen.
Set as Active	Sets selected recipe as the current or active recipe to weld.
Copy Button	Press the Copy button to duplicate the recipe.
Delete Button	Press the Delete button to delete the recipe. NOTICE Deleting an active recipe is not allowed.
Info Button	Press the Info button to display information about the recipe.

5.7.2 New Recipe

After analyzing your specific application, you can determine the Weld Mode to use to weld your parts. There are six Weld Modes to choose from Time, Energy, Peak Power, Ground Detect, Absolute Distance and Collapse Distance.

Figure 5.12 New Recipe

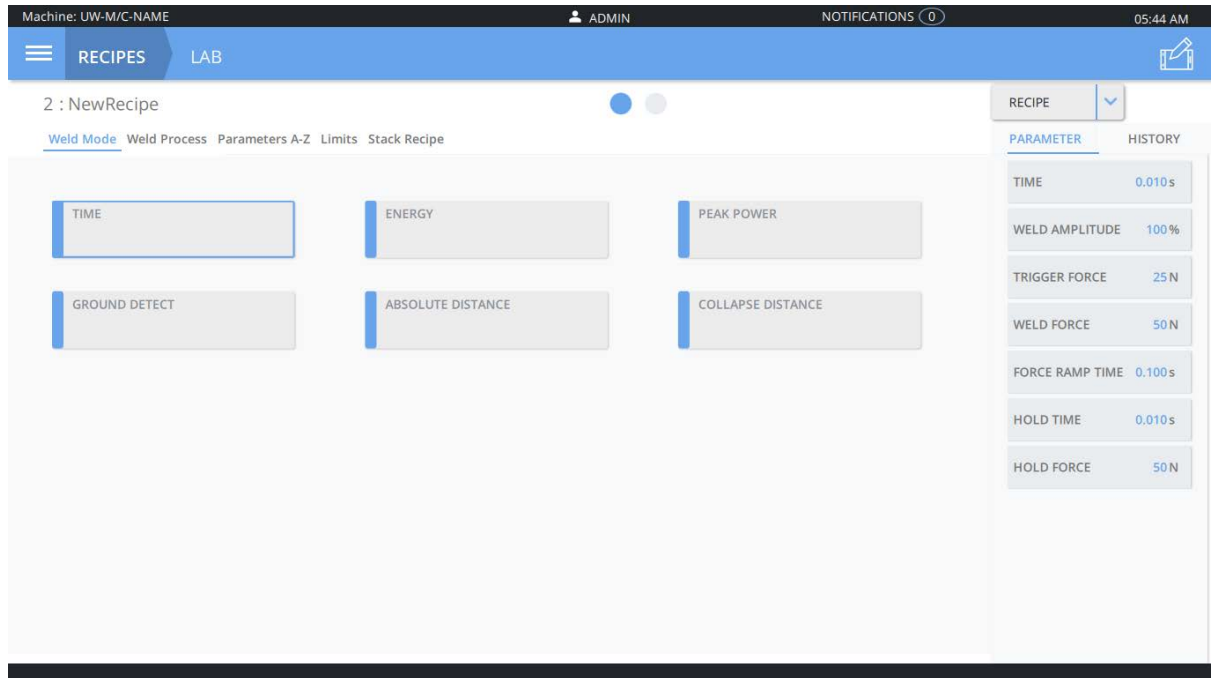

5.7.3 Weld Modes

The following table describes each mode:

Mode	Description
Time	Use Time mode to select the length of time (in seconds) that ultrasonic energy is applied to your parts. Within Time mode, you can also select several other parameters, ranging from Hold Time (in seconds) to Suspect and Reject Limits.
Energy	Use Energy mode to select the amount of ultrasonic energy (in joules) that is applied to your parts. Within Energy mode, you can also select several other parameters, ranging from Hold Time (in seconds) to Suspect and Reject Limits.
Peak Power	Use Peak Power mode to select the maximum watts power that will be used to process your welds. When the power level you set is reached, ultrasonics will be terminated. From within Peak Power Mode, you can also select several other parameters, ranging from Hold Time (in seconds) to Suspect and Reject Limits.
Ground Detect	Use Ground Detect mode to have ultrasonic energy turn off when the horn comes in contact with your electrically isolated fixture or anvil. The electrically isolated fixture should be so designed that the insulator allows no continuity to the actuator base. It is necessary to install Ground Detect cable (see Table 6.14 for more information) from the connector on the side of the actuator to your isolated fixture/anvil in order to utilize this feature. From within Ground Detect Mode, you can also select several other parameters, ranging from Hold Time (in seconds) to Suspect and Reject Limits.

Mode	Description
Absolute Distance	You can use the Absolute Distance Mode to select the distance (in inches or millimeters) the horn will travel before ultrasonic energy is terminated. Within Absolute Mode, you can also select several other parameters ranging from Hold Time (in seconds) to Suspect and Reject limits.
Collapse Distance	You can use the Collapse Distance Mode to select the distance (in inches or millimeters) your part will be collapsed before ultrasonic energy is terminated. This distance parameter can be set when in Collapse Mode to establish Suspect and Reject Limits. Total Collapse Limits in Collapse Mode is that value achieved at the end of Hold. Within Collapse Mode, you can also select several other parameters, ranging from Hold Time (in seconds) to Suspect and Reject limits.

5.7.4 Weld Mode Parameters

Parameter	Description
Time	Set the length of time (in seconds) that ultrasonic energy will be transmitted to your parts. Only available in Time mode.
Energy	Set the amount of energy (in joules) that will be transmitted to your parts. NOTICE Only available in Energy mode.
Peak Power	Set the peak power level (in watts) at which the weld is terminated. NOTICE Only available in Peak Power mode.
Scrub Time	Sets the scrub time (in seconds) when ground detect mode is selected. NOTICE Only available in Ground Detect mode.
Absolute Distance	Set the vertical distance (in millimeters) that the horn travels from the ready position before ultrasonics are terminated. NOTICE Only available in Absolute Distance mode.
Collapse Distance	Set the vertical distance (in millimeters) that your part collapses before ultrasonics are terminated. NOTICE Only available in Collapse Distance mode.
Weld Amplitude	You can set the amplitude of the ultrasonic energy that will be delivered in any welding mode. Default is to use 100% of the available amplitude. By changing the amplitude to some lesser percentage of the total available, or by setting the amplitude to begin at one level and finish at another, you can fine tune your overall welding procedure without making changes to your tooling.
Trigger Force	Set the number of newtons of trigger force that will trigger ultrasonics. When the force on your part is equal to the value you have set, ultrasonic energy is applied.
Weld Force	Actuator force at the end of weld.
Hold Time	Sets the duration (in seconds) of the Hold step (the step during which there is no ultrasonic energy transmitted to your part, but force is maintained).
Hold Force	Actuator force at the end of hold.

5.7.5 Weld Process Parameters

5.7.5.1 Pretrigger

You can select whether the ultrasonic energy will be started before the horn makes contact with the part. If you select ON, you can set the distance at which the pretrigger ultrasonics will be started, and the amplitude that will be used. When Auto Pretrigger is used, ultrasonic energy will start when the horn leaves the home position.

Figure 5.13 Pretrigger

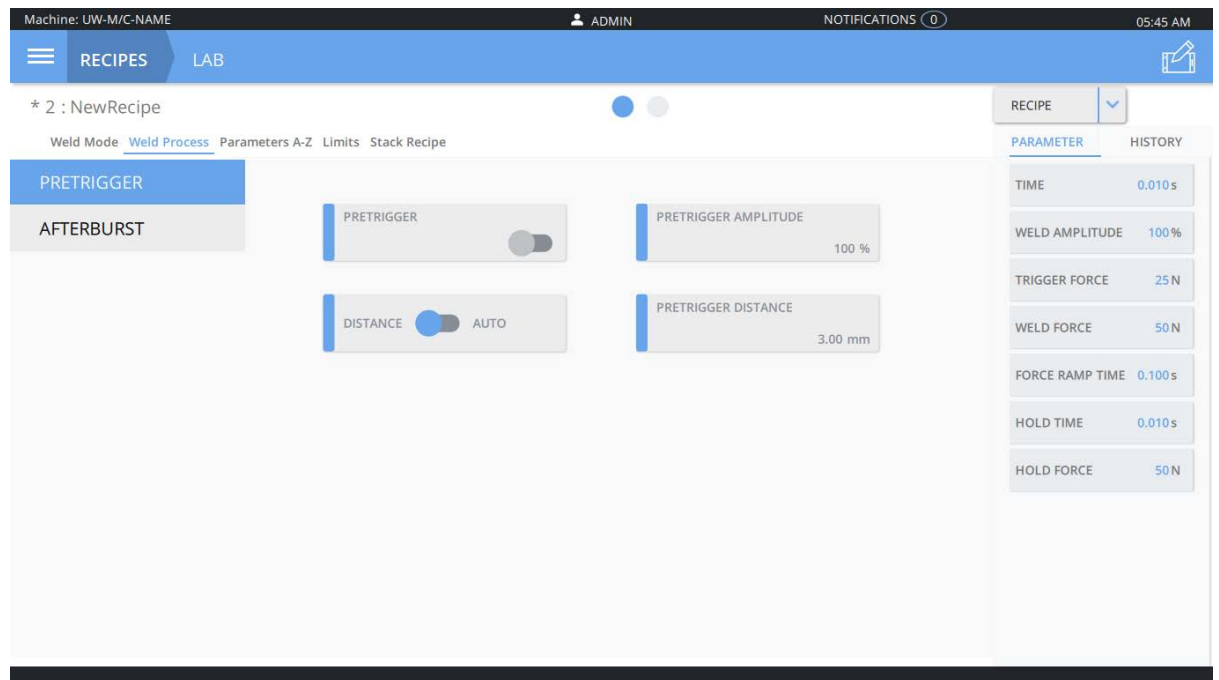

Table 5.3 Parameters A-Z

Function	Description
Pretrigger	Press the Pretrigger button to toggle the functionality between ON and OFF. Ultrasonic energy will be started before the horn makes contact with the part.
Pretrigger Amplitude	The amplitude at the horn face during pretrigger.
Distance/Auto	If set to Distance, the value in Pretrigger Distance is used. If set to Auto, ultrasonic energy will start when the horn leaves the home position.
Pretrigger Distance	Set the distance at which the pretrigger ultrasonics will be started.

5.7.5.2 Afterburst

You can select whether there will be a burst of ultrasonic energy after welding is complete. This feature is useful for removing parts stuck to the horn. If you select ON, you can also set the delay and length of the afterburst (in seconds), and the amplitude that will be used.

Figure 5.14 Afterburst

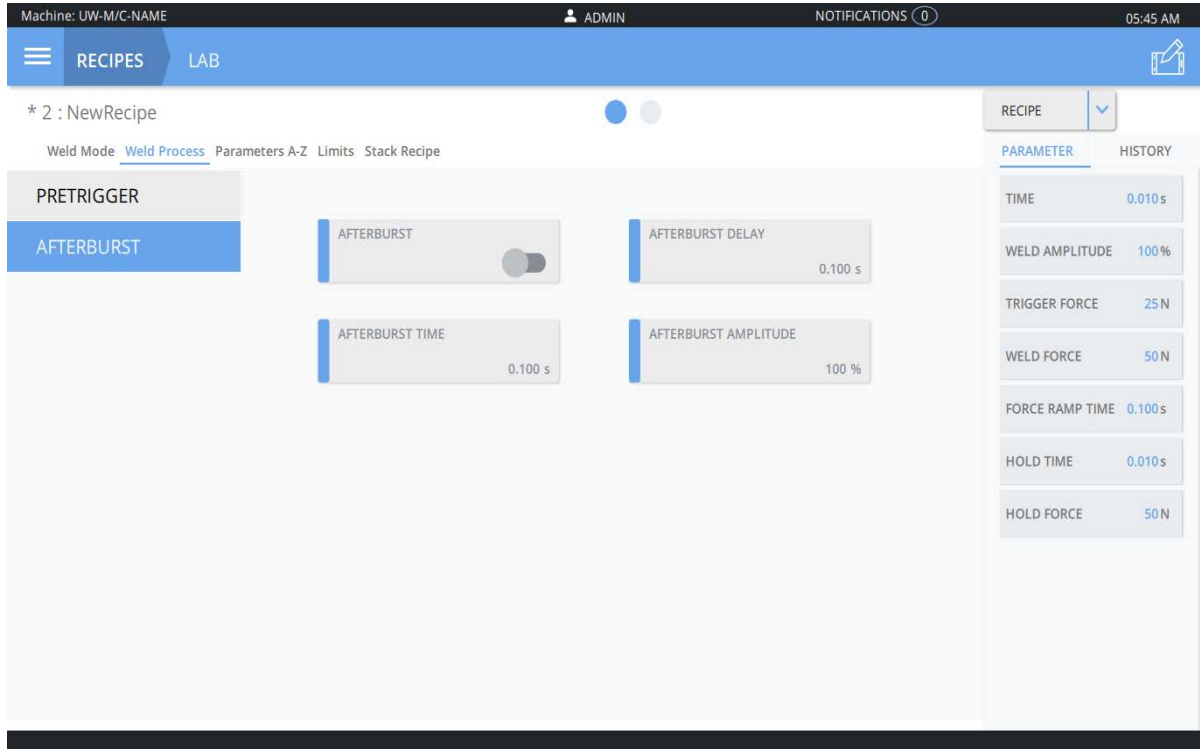

Table 5.4 Parameters A-Z

Function	Description
Afterburst	Press the Afterburst button to toggle the functionality between ON and OFF.
Afterburst Amplitude	The amplitude at the horn face during the afterburst step.
Afterburst Delay	Time delay between the end of the weld and the start of the afterburst.
Afterburst Time	The duration of the afterburst.

5.7.6 Parameters A-Z

Displays all the available parameters for the selected weld mode in alphabetic order.

Figure 5.15 Parameters A-Z

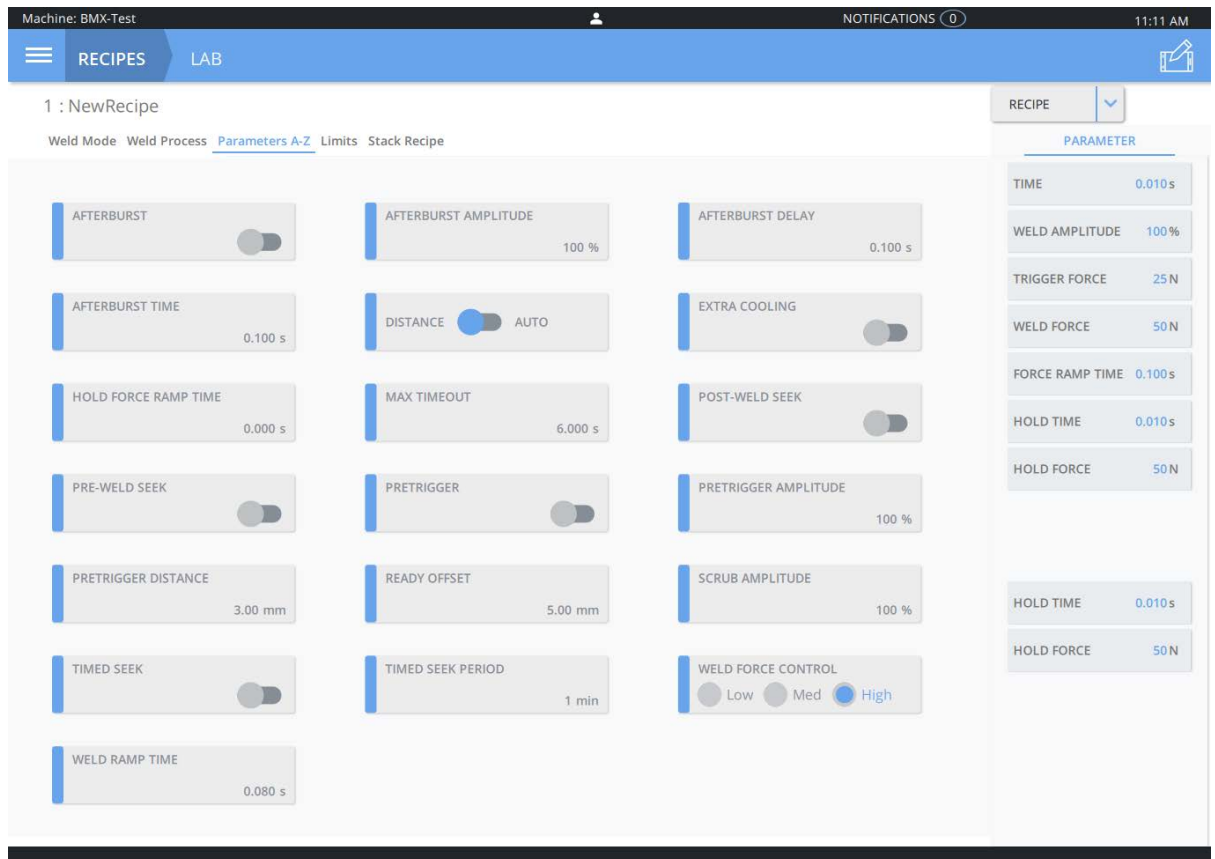

Table 5.5 Parameters A-Z

Function	Description
Afterburst	Press the Afterburst button to toggle the functionality between ON and OFF. If set to ON, there will be a burst of ultrasonic energy after welding is complete. This feature is useful for removing parts stuck to the horn.
Afterburst Amplitude	The amplitude at the horn face during the afterburst step.
Afterburst Delay	Time delay between the end of the weld and the start of the afterburst.
Afterburst Time	The duration of the afterburst.
Distance/Auto (Pretrigger)	If set to Distance, the value in Pretrigger Distance is used. If set to Auto, ultrasonic energy will start when the horn leaves the home position.
Extra Cooling	When set to ON, allows cooling air to start when the carriage leaves the home position and remains on throughout the cycle. When OFF, air is applied at ultrasonics application.
Hold Force Ramp Time	Force ramp used during Hold Time.
Max Timeout	Maximum amount of time the system will allow ultrasonics to be On.
Post-Weld Seek	Provides a short burst of energy at the end of the weld to automatically re-tune the system, if required.

Table 5.5 Parameters A-Z

Function	Description
Pre-Weld Seek	Provides a short burst of energy before weld to automatically re-tune the system, if required.
Pretrigger	Press the Pretrigger button to toggle the functionality between ON and OFF. Ultrasonic energy will be started before the horn makes contact with the part.
Pretrigger Amplitude	The amplitude at the horn face during pretrigger.
Pretrigger Distance	Set the distance at which the pretrigger ultrasonics will be started.
Ready Offset	The distance from Home at which the actuator will cycle at Ready position.
Scrub Amplitude	<p>Sets the scrub amplitude (in percentage) when ground detect mode is selected.</p> <p>NOTICE Only available in Ground Detect mode.</p>
Timed Seek	When set to On, the system will perform a Seek once every certain amount of time to update horn resonant frequency to memory. This is especially useful when the welding process affects the actual temperature of the horn, causing a resonant frequency shift.
Timed Seek Period	The period of Timed Seek activation.
Weld Force Control	Sets the rate at which the actuator will attempt to maintain the force during the weld.
Weld Ramp Time	This controls how fast the amplitude of the horn rises from 0 to 100. Long ramp times may be useful when using large horns or high gain stacks.

5.7.7 Limits

5.7.7.1 Setup Limits

Setup Limits set the minimum and maximum parameter changes allowed to be made for a validated recipe. When Setup Limits are enabled, a technician can change a validated and locked recipe's setup parameters within the minimum and maximum range set.

Figure 5.16 Limits - Setup

The screenshot shows the 'Limits - Setup' configuration screen in the Branson software. The interface includes a top navigation bar with 'RECIPES' and 'LAB' tabs, a left sidebar with 'Setup', 'Control', and 'Suspect & Reject' options, and a main area with various parameter sliders and a 'GLOBAL SETUP' toggle. A right-hand panel displays a table of parameters and their current values.

PARAMETER	HISTORY
TIME	0.010 s
WELD AMPLITUDE	100 %
TRIGGER FORCE	25 N
WELD FORCE	50 N
FORCE RAMP TIME	0.100 s
HOLD TIME	0.010 s
HOLD FORCE	50 N

5.7.7.2 Control Limits

If you set the toggle to On, you can set control cutoffs for:

- Frequency Low (Hz)
- Frequency High (Hz)
- Energy High (J)
- Energy (J)
- Ground Detect
- Peak Power (W)
- Absolute Distance (mm)
- Collapse Distance (mm)
- Time (s)

The GSX-E1 system uses these Control Limits in addition to the primary weld mode and parameters to determine the end of the welding cycle.

Figure 5.17 Limits - Control

The screenshot displays the 'Limits' configuration page in the Branson welding control interface. The page is titled '* 2 : NewRecipe' and includes a sidebar with 'Setup', 'Control', and 'Suspect & Reject' options. The main area shows various control parameters with their current values and units. A right-hand panel displays a list of parameters and their values.

PARAMETER	HISTORY
TIME	0.010 s
WELD AMPLITUDE	100%
TRIGGER FORCE	25 N
WELD FORCE	50 N
FORCE RAMP TIME	0.100 s
HOLD TIME	0.010 s
HOLD FORCE	50 N

5.7.7.3 Suspect & Reject Limits

You can select whether to use Suspect & Reject Limits to indicate that a part does not have or might not have a good weld. You can set limits of minimum and maximum time allowed for:

- Weld Time
- Peak Power
- Collapse Distance
- End of Weld Force
- Energy
- Absolute Distance
- Trigger Distance
- Frequency

Figure 5.18 Limits - Suspect & Reject

The screenshot displays the 'Limits - Suspect & Reject' configuration screen in the Branson control interface. The interface includes a navigation menu on the left with 'Suspect & Reject' selected. The main configuration area contains two toggle switches for 'GLOBAL SUSPECT' and 'GLOBAL REJECT', both currently turned off. Below these are eight parameter input fields: TIME, ENERGY, PEAK POWER, ABSOLUTE DISTANCE, COLLAPSE DISTANCE, TRIGGER DISTANCE, END WELD FORCE, and FREQUENCY. A right-hand panel shows a 'PARAMETER HISTORY' table with the following data:

PARAMETER	HISTORY
TIME	0.010 s
WELD AMPLITUDE	100 %
TRIGGER FORCE	25 N
WELD FORCE	50 N
FORCE RAMP TIME	0.100 s
HOLD TIME	0.010 s
HOLD FORCE	50 N

5.7.8 Stack Recipe

Stack recipe sets parameters that are stack dependent such as frequency.

Figure 5.19 Stack Recipe

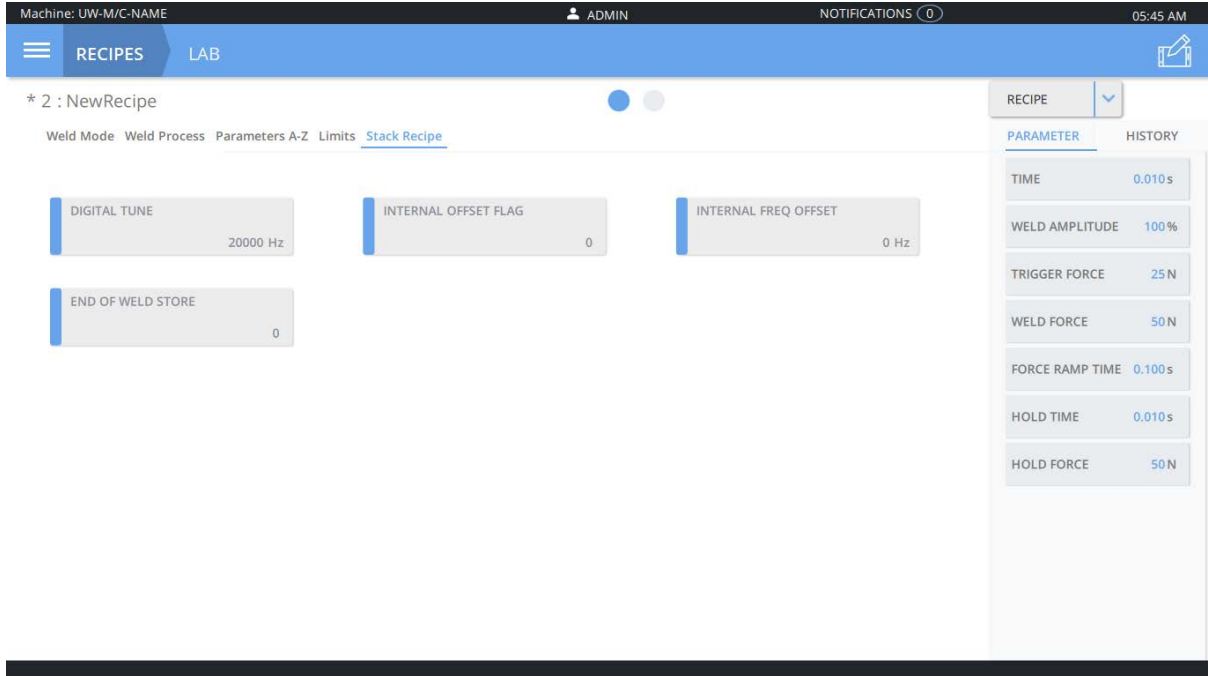

Table 5.6 Stack Recipe

Function	Description
Digital Tune	Starting frequency set from horn signature or manually entered.
Internal Offset Flag	Internal frequency offset function activation: 0: OFF 1: ON
Internal Frequency Offset	Sets the frequency offset as either a positive or negative value offset from digital tune.
End of Weld Store	Save the frequency at the end of the weld as the starting frequency for the following weld. 0: OFF 1: ON

5.7.9 Production Setup

Set the batch setup, production instructions and recipe description from this menu. Press the Reset button to reset the cycle count to 0.

Figure 5.20 Production Setup

The screenshot displays the 'Production Setup' interface. At the top, a navigation bar shows 'Machine: UW-M/C-NAME', 'ADMIN', 'NOTIFICATIONS (0)', and '06:19 AM'. Below this, a blue header contains 'RECIPES' and 'PRODUCTION SETUP'. A breadcrumb trail shows '1: NewRecipe'. The main content area is divided into two columns. The left column, titled 'BATCH SETUP', contains a 'Cycle Count' field with the value '68' and a 'RESET' button. The right column contains two text input fields: 'Production Instruction' and 'Recipe Description'. At the bottom right of the form, there are 'CANCEL' and 'SAVE' buttons.

5.7.9.1 Batch Setup

Set the batch counter from this menu. Press the Batch Setup button to toggle between ON and OFF.

Figure 5.21 Batch Setup

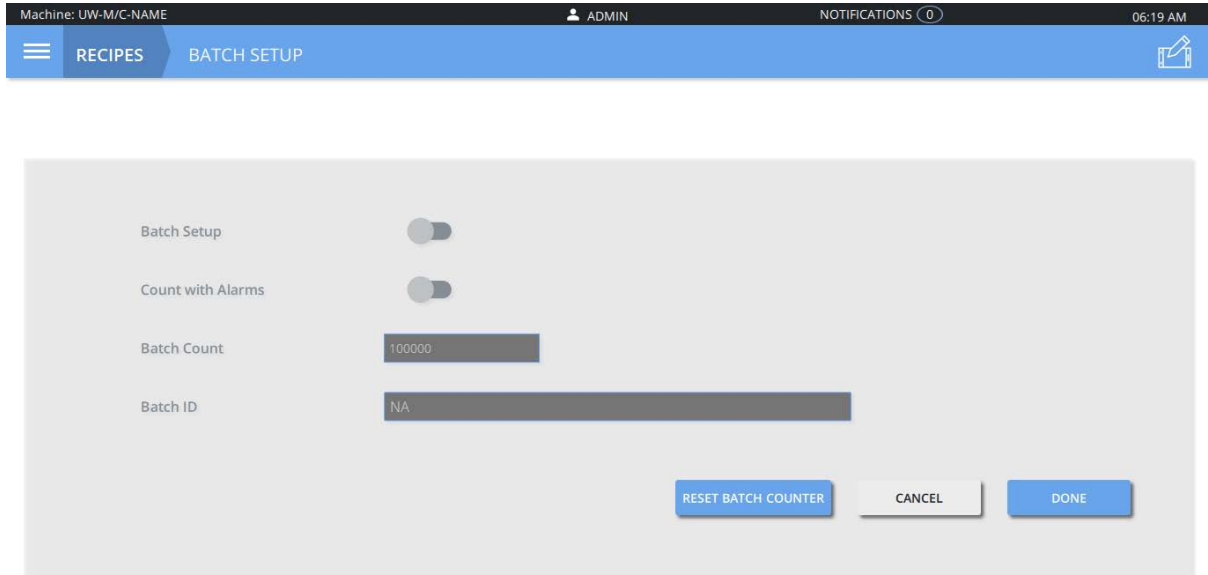

Name	Description
Batch Setup	Toggle between ON and OFF.
Count With Alarms	If set to ON, weld cycles with alarms will also increment the counter.
Batch Count	Set the number of welds required in the batch.
Batch ID	Used to track a batch of welds. If Batch ID is used, it must be changed before each new batch is run.
Reset Batch Counter	Resets the batch count.

5.8 Production

Figure 5.22 Production Screen

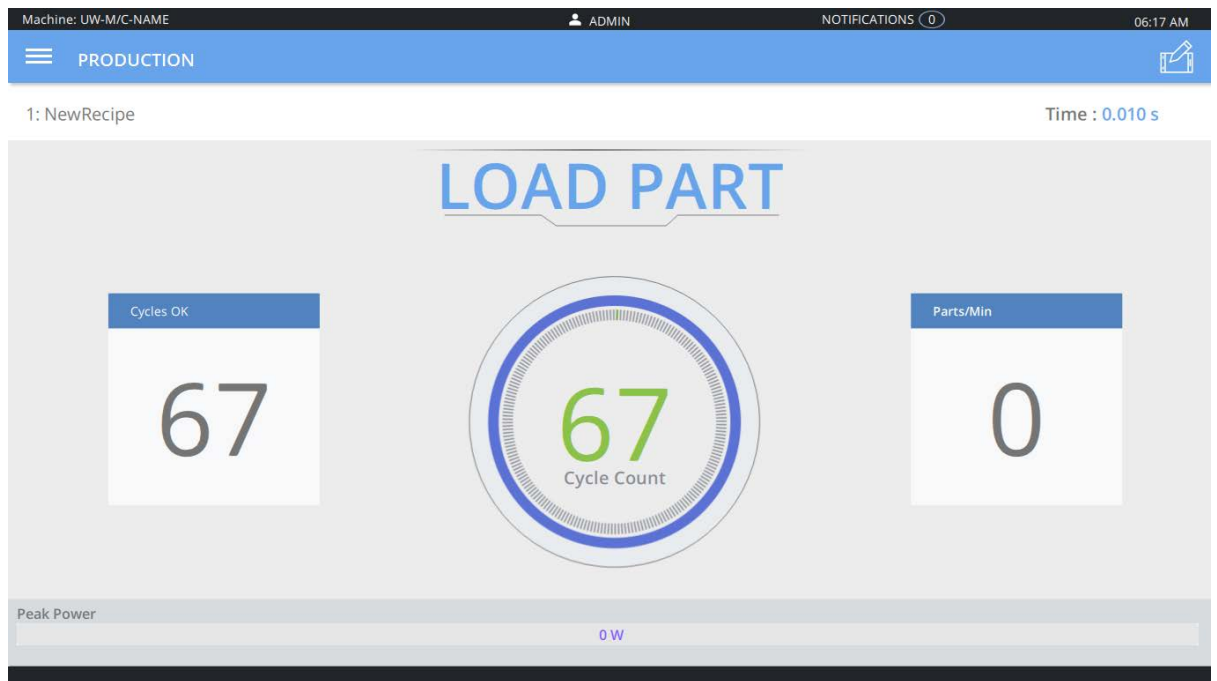

Name	Description
Load Part	Indicates welder is ready for part to be loaded.
Good	Number of no alarm welds since starting run.
Part/Min	Current rate production of parts per minute.
Cycles	Total number of cycles since starting run.
Peak Power	Graphical and percent representation of the last weld peak power.

5.9 Analytics

5.9.1 Results

Access the Analytics screen to display the graphs of several available parameters: amplitude, power, frequency, force, collapse distance, absolute distance, velocity, current, phase.

Each parameter has a check box to the left of its name. Only checked parameters will be displayed.

Figure 5.23 Analytics

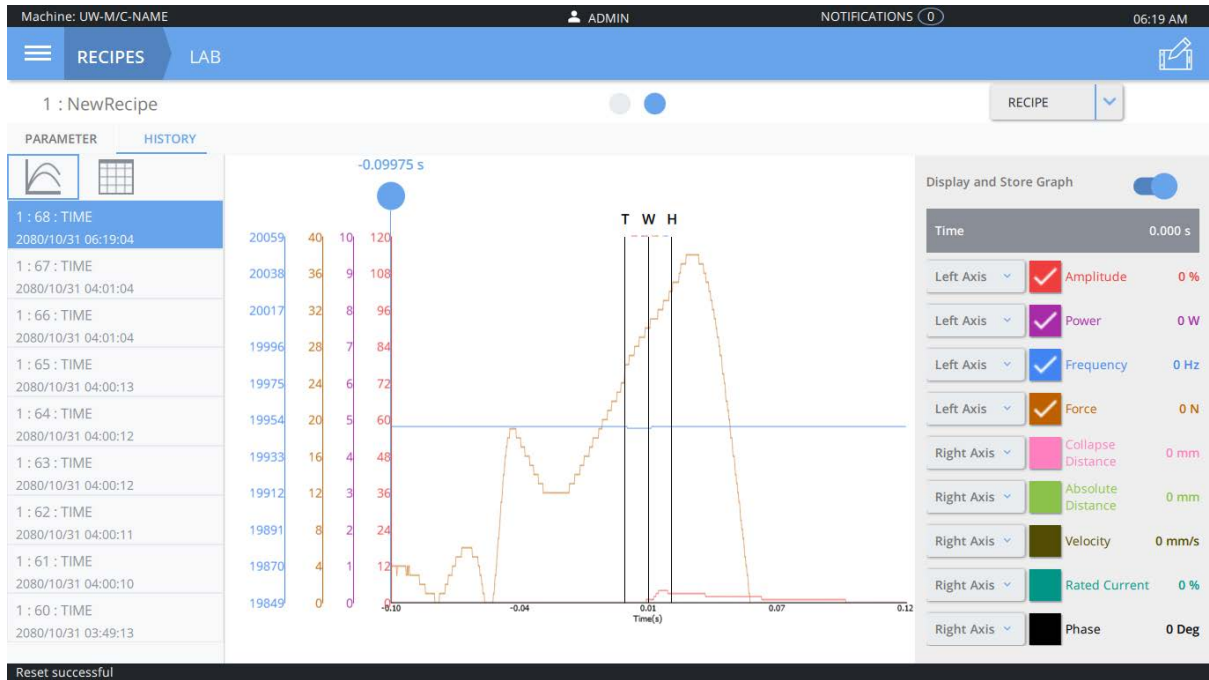

5.9.2 Alarms

Displays the alarm log. See [Appendix A: Alarms](#) for more information.

Figure 5.24 Alarms

The screenshot displays the 'ALARMS' section of the Branson Analytics interface. At the top, the machine name is 'UW-M/C-NAME', the user is 'ADMIN', and there are '0' notifications. The time is '05:46 AM'. The 'ANALYTICS' header includes a 'RESULTS' tab and an 'ALARMS' tab, with a 'GENERATE REPORT' button on the right.

The main table shows the following alarm events:

Error type	Alarm ID	Recipe	Recipe Ver	Cycle#	PC Assembly	AC Assembly	Date/Time
HMI Connection Lost	63E	0	0	0	NA	NA	2080-10-31 05:37
Description Internal Communication failure. Contact Branson Service.		User Id ADMIN		Alarm Type 600		Part# 0	
AC Line Voltage Lost	63C	1	3	0	NA	NA	2080-10-31 04:03
Start Switch Lost	609	1	3	0	NA	NA	2080-10-31 03:25
Linear Encoder Fault	EF4	1	3	39	NA	NA	2080-10-31 03:21

A 'RESULTS' button is visible next to the expanded alarm description.

5.10 System

Set and configure GSX-E1 system settings, tooling, calibration, data, and view system information.

Figure 5.25 System

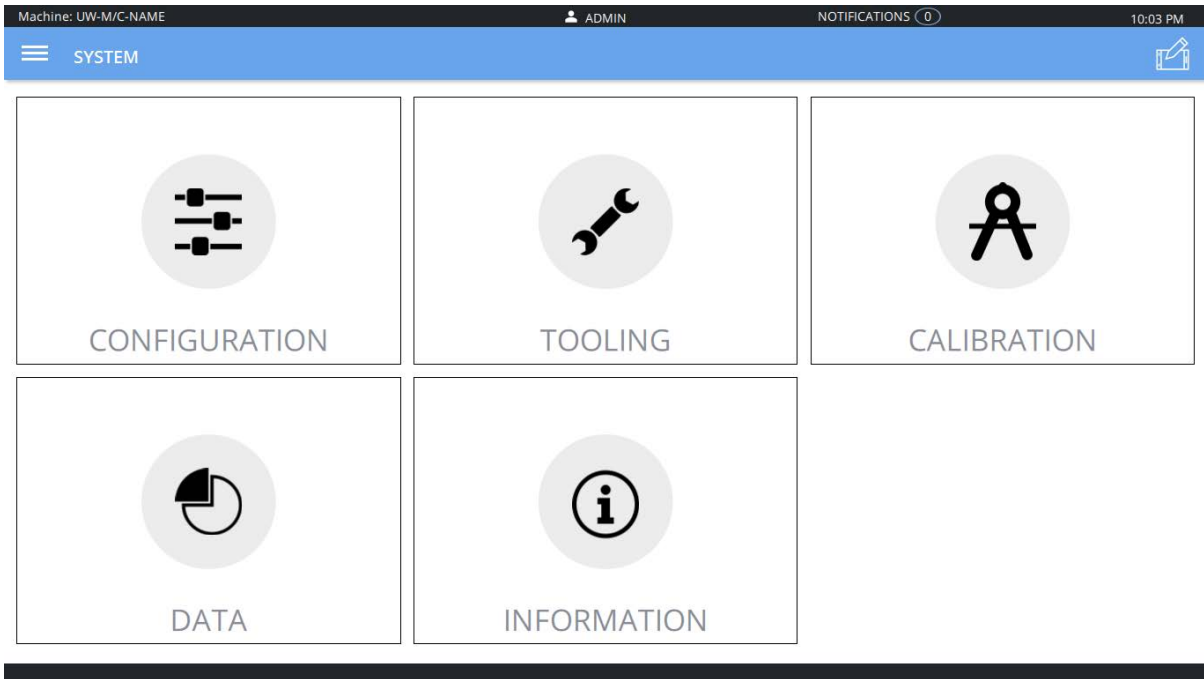

Name	Description
Configuration	Set and configure system settings. System settings apply to all recipes.
Tooling	Future capability coming soon.
Calibration	Force calibration setup.
Data	Create reports and export to USB and configure web service communication settings.
Information	View the event log, and software details.

5.10.1 Configuration

Table 5.7 Configuration Options

Command List	
General	User Authority
User Management	Change Password
User I/O	Alarm Management

5.10.1.1 General

Figure 5.26 General

Name	Description
Memory Full Action	If set to Stop, does not allow any welding until memory is cleared. If set to Continue, the system will write over older memory.
Language	Change the language of the GSX-E1 interface. After selecting the desired language, press Save and restart the GSX-E1 system.
PS Power On Option	Choose whether to have the power supply perform a seek or a scan at power-up.
Machine Name	Assign an identification name for the GSX-E1 system.
Authority Check	Authority check ensures that users logging into the power supply only have access to features dependent on their authority level. Authority Check needs to be enable to use web services. See section Appendix D: Web Services for more information.
Start Screen	Choose whether to start at the Dashboard, Recipes, Production or System screen at startup.

Name	Description
Barcode recall recipe prefix	<p>Enter a character (letter or symbol) that will indicate a recipe is to be recalled when scanned with a barcode. The number following the character indicates which recipe number. Example; Barcode recall recipe prefix = R indicates if a barcode reader sees the letter R as the first character of a barcode, it will recall a recipe based on the number after R on the barcode.</p>
Part ID Scan	<p>Users can scan a Part ID linear barcode and the system will associate the next weld with the scanned part ID.</p> <p>If set to ON, a USB barcode reader must read and record the Part ID before allowing the weld to occur. When set to ON and after a weld cycle, the welder will stay out of ready mode until another Part ID is read. If set to OFF, no Part ID reading is required before a weld.</p> <p>NOTICE Part ID can be up to 50 characters in length.</p>

5.10.1.2 User Management

NOTICE	
	Only executive level users can manage users.

Displays current users and their creation/modification date. Users can be added or modified from this screen.

Figure 5.27 User Management

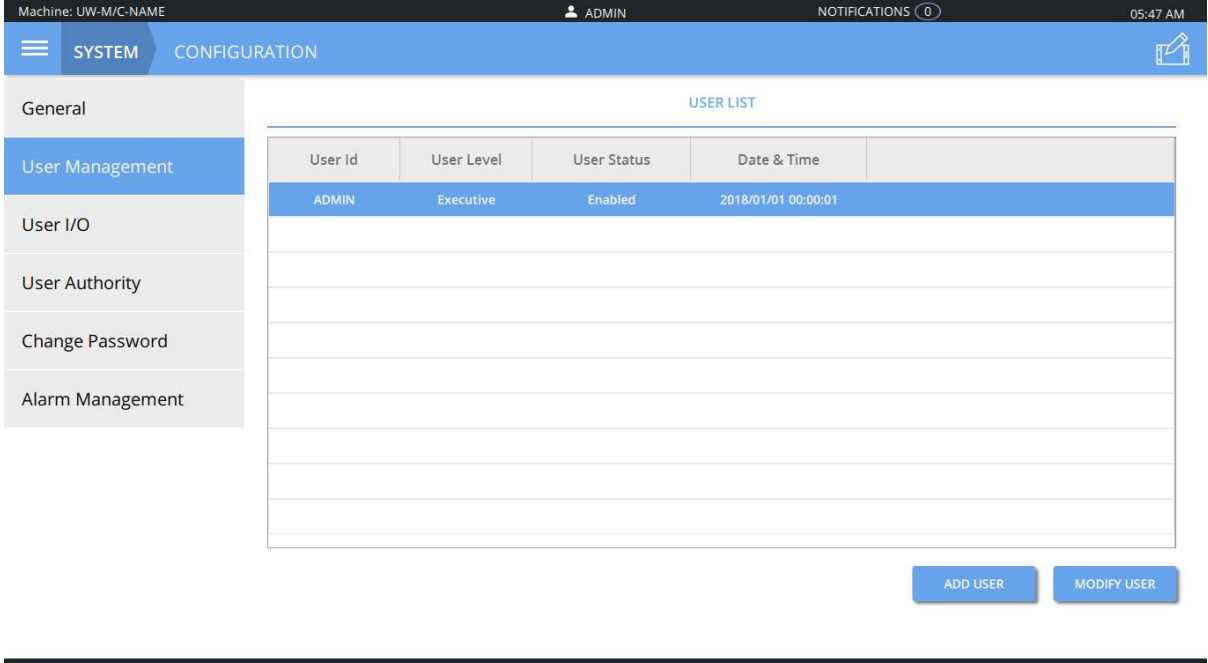

User Id	User Level	User Status	Date & Time
ADMIN	Executive	Enabled	2018/01/01 00:00:01

Add/Modify User

Press the Add User button to add a new User ID or select an existing user from the list and press the Modify User button to modify it.

Figure 5.28 Add User

The screenshot shows the 'ADD USER' configuration screen. The top navigation bar includes 'SYSTEM' and 'CONFIGURATION'. The left sidebar lists options: General, User Management (selected), User I/O, User Authority, Change Password, and Alarm Management. The main form contains the following fields:

- User id:** A text input field with the placeholder 'Enter Username'.
- Password:** A text input field with the placeholder 'Enter Password'.
- Confirm Password:** A text input field with the placeholder 'Enter Confirm Password'.
- User Level:** A dropdown menu currently set to 'Executive'.
- Status:** Radio buttons for 'ENABLED' (selected) and 'DISABLED'.

At the bottom right of the form are 'CANCEL' and 'SAVE' buttons.

Name	Description
User ID	Set the new User ID name.
Password	Set the password for the User ID. NOTICE Password must have at least one capital letter, one lower case letter, one number, and one special character available. The minimum length of the password must be of 8 character and max is 10 character.
User Level	Set the user level to Operator, Technician, Supervisor, or Executive. <ul style="list-style-type: none"> Operator can run Validated Recipes, View Setup, System Information, Weld History, Alarm Log, Event Log, and Weld Results Technician level adds Unvalidated Recipes, Horn Down, Sequencing, Recipe changes, Calibration, and Diagnostics Supervisor level adds Validating Setup, and System Configuration Executive level has rights to all settings
Status	Enable or disable users.

5.10.1.3 User I/O

Use this menu to configure the GSX-E1 system I/O according to your specific interfacing needs. Use the buttons on the bottom to save settings, or restore to factory default settings.

Power Supply I/O

Figure 5.29 Power Supply I/O

The screenshot displays the configuration page for the Power Supply I/O. The interface includes a top navigation bar with 'SYSTEM' and 'CONFIGURATION' tabs. A sidebar on the left lists various system management options, with 'User I/O' currently selected. The main content area is split into two columns: 'Power Supply I/O' and 'Actuator I/O'. The 'Power Supply I/O' column is further divided into 'DIGITAL INPUTS', which lists 13 digital input channels (J17-01 to J17-23). Each channel is configured with a checkbox, a dropdown menu (e.g., 'Cycle Abort', 'U/S Disable', 'Reset', 'Not Used', 'Hold Delay', 'Horn Seek'), a voltage indicator (0V or 24V), and a toggle switch. The 'Actuator I/O' column is divided into 'DIGITAL OUTPUTS', listing 10 digital output channels (J17-07 to J17-22) with similar configuration options. At the bottom right of the configuration area, there are two buttons: 'SAVE' and 'RESTORE DEFAULTS'.

Digital Inputs

Table 5.8 GSX-E1 Power Supply I/O Descriptions - Inputs

Input	Level Range	Definition	Default Value & Logic
Cycle Abort	0/24VDC	Terminates a running cycle and returns the actuator to home position.	24VDC - Terminates a cycle.
U/S Disable	0/24VDC	Disables the ultrasonics from operating during the weld cycle.	24VDC - Disables Ultrasonics during the weld cycle.
Reset	0/24VDC	Resets and clears a fault or weld alarm.	24VDC - Resets/clears an alarm.
Hold Delay	0/24VDC	Delays the start of the hold cycle after the weld cycle is complete.	24VDC - Initiates the start of the hold cycle.
Horn Seek	0/24VDC	A low amplitude and short ultrasonic burst to find the tuning frequency of the horn.	24VDC - Initiates a horn seek.

Digital Outputs

Table 5.9 GSX-E1 Power Supply I/O Descriptions - Outputs

Output	Level Range	Definition	Default Value & Logic
Ready	0/24VDC	The system is in a ready state to begin a cycle.	24VDC - The system is in a ready state.
Sonics Active	0/24VDC	The ultrasonics are on.	24VDC - Ultrasonics are active/on.
General Alarm	0/24VDC	An alarm or fault has occurred during a cycle or system check.	24VDC - An alarm occurred.
Cycle Running	0/24VDC	A cycle is in progress.	24VDC - Cycle is in progress.
Horn Seek	0/24VDC	A low amplitude and short ultrasonic burst to find the tuning frequency of the horn.	24VDC - A horn seek is in progress.
Cycle OK	0/24VDC	A cycle is complete and no alarms or faults occurred during the cycle.	24VDC - cycle is complete and no alarms occurred.
Suspect Alarm	0/24VDC	A weld characteristic was outside of its set suspect minimum or maximum limit during the cycle.	24VDC - A weld characteristic was outside of its set suspect limit range.
Reject Alarm	0/24VDC	A weld characteristic was outside of its set reject minimum or maximum limit during the cycle.	24VDC - A weld characteristic was outside of its set reject limit range.
Weld Active	0/24VDC	The weld state is active in the cycle.	24VDC - Weld state is active.
Hold Active	0/24VDC	The hold state is active in the cycle.	24VDC - Hold state is active.

Actuator I/O

Figure 5.30 Actuator I/O

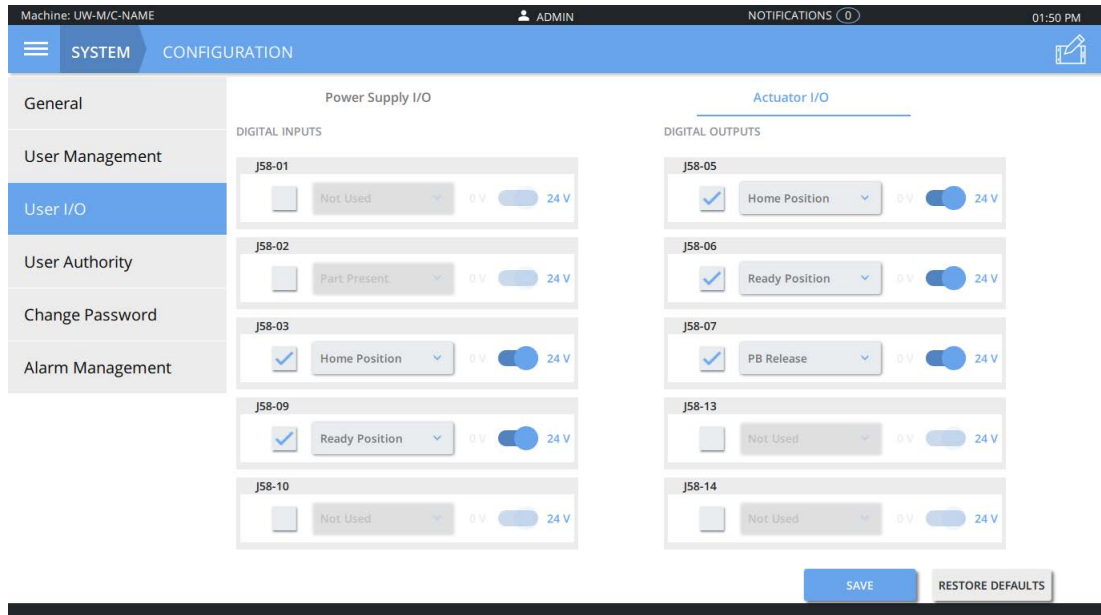

Digital Inputs

Table 5.10 GSX-E1 Actuator I/O Descriptions - Inputs

Input	Level Range	Definition	Default Value & Logic
Part Present	0/24VDC	An external Input to let the system controller know that the part to be welded in position. NOTICE Use this input only with the benchtop GSX-E1.	24VDC - The part to be welded is in position.
Home Position	0/24VDC	Commands the actuator to go to its home position when the start switches are closed.	24VDC - Configures the actuator to go to its home position.
Ready Position	0/24VDC	Commands the actuator to go to its ready position after power up or an e-stop and the start switches are closed.	24VDC - Configures the actuator to go to its ready position.

Digital Outputs

Table 5.11 GSX-E1 Actuator I/O Descriptions - Outputs

Output	Level Range	Definition	Default Value & Logic
Home Position	0/24VDC	The Actuator is at its home position.	24VDC - The actuator is at its home position.
Ready Position	0/24VDC	The actuator is at its ready position.	24VDC - The actuator is at its ready position.
PB Release	0/24VDC	The hold cycle is complete and the start switches can be opened.	24VDC - Hold cycle is complete and the start switches can be opened.
Hold Active	0/24VDC	The hold state is active in the cycle.	24VDC - The hold state is active.

5.10.1.4 User Authority

User Authority ensures that users logging into the GSX-E1 system only have access to features dependent on their authority level.

Operators Authority Options

Set additional authority options for the Operator user level.

Table 5.12 Operators Authority Options

Authority	Permission
Run unvalidated weld recipes	Can run validated and unvalidated recipes.
	Can't switch to any recipe.
Set as active	Can run validated recipes.
	Can switch to validated recipes.
	Can't switch to unvalidated recipes.
	Can't run unvalidated recipes.
Run unvalidated weld recipes + Set as active	Can run validated and unvalidated recipes.
	Can switch to validated and unvalidated recipes.
Reset alarm	Can reset any resettable alarm.
Reset batch counter	Can reset batch counter.
Barcode recipe recall	Can change the recipe with barcode scanner.
	Can't change suffix letter for barcode recipe recall.
Actuator setup	Have access to actuator setup screen.
Modify recipe values	Access to modify recipe values within Setup limits if setup limits are enabled.
	<div style="background-color: #003366; color: white; padding: 2px;">NOTICE</div> Enabled through setup limits.

NOTICE	
	HMI must be restarted for user authority changes to take effect.

Figure 5.31 User Authority



Global User Settings

Additionally, you can configure the following global user settings:

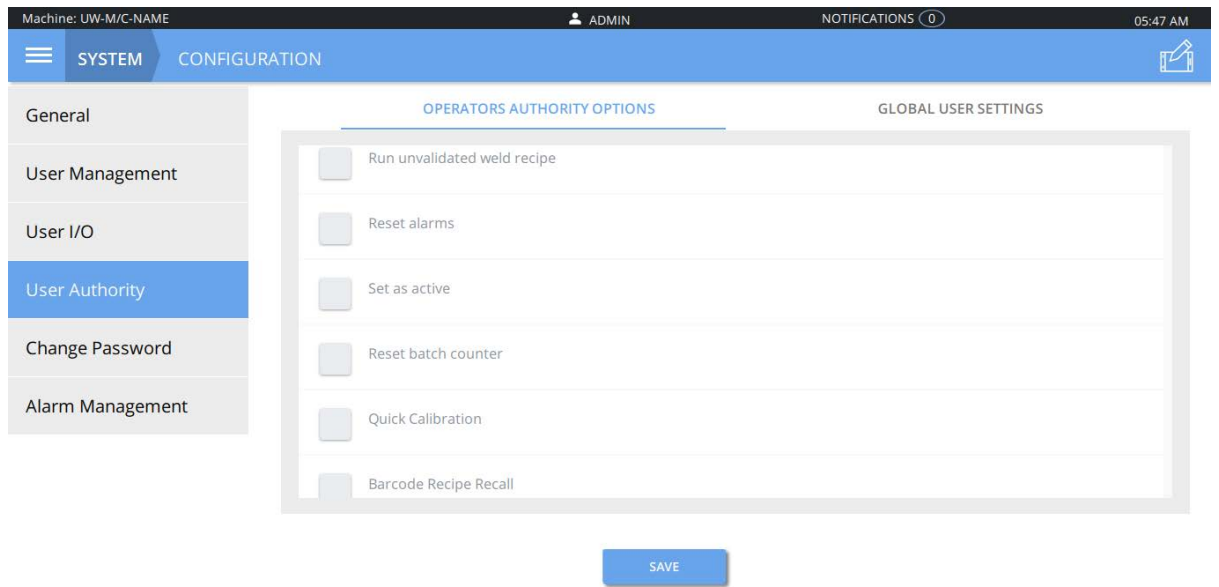
Figure 5.32 Global User Settings

The screenshot shows the 'Global User Settings' configuration page. The top navigation bar includes 'SYSTEM' and 'CONFIGURATION'. The left sidebar lists various system settings, with 'User Authority' currently selected. The main content area is titled 'GLOBAL USER SETTINGS' and contains two settings:

- Password Expiration:** A text input field containing the value '90' followed by the unit 'day(s)'.
- Idle Time Logout:** A text input field containing the value '30' followed by the unit 'minute(s)'.

A blue 'SAVE' button is positioned below the settings area.

Name	Description
Password Expiration	Set the time in days before users will have to change their password; otherwise it will expire and the User ID will be locked/disabled.
Idle Time Logout	Set the time after which the system will automatically logout the user in case of no activity.

5.10.1.5 Change Password

Change password for the current user.

NOTICE	
	Password must have at least one capital letter, one lower case letter, one number, and one special character available. The minimum length of the password must be of 8 character and max is 10 character.

Figure 5.33 Change Password



The screenshot displays the Branson system configuration interface. At the top, the status bar shows 'Machine: UW-M/C.NAME', 'ADMIN', 'NOTIFICATIONS (0)', and '05:47 AM'. The navigation menu includes 'SYSTEM' and 'CONFIGURATION'. The left sidebar lists various configuration options: 'General', 'User Management', 'User I/O', 'User Authority', 'Change Password' (highlighted), and 'Alarm Management'. The main content area is titled 'Change Your Password' and features a dialog box for the 'ADMIN' user. The dialog contains three input fields: 'Current Password', 'New Password', and 'Confirm Password'. Below the input fields are 'CANCEL' and 'OKAY' buttons.

5.10.1.6 Alarm Management

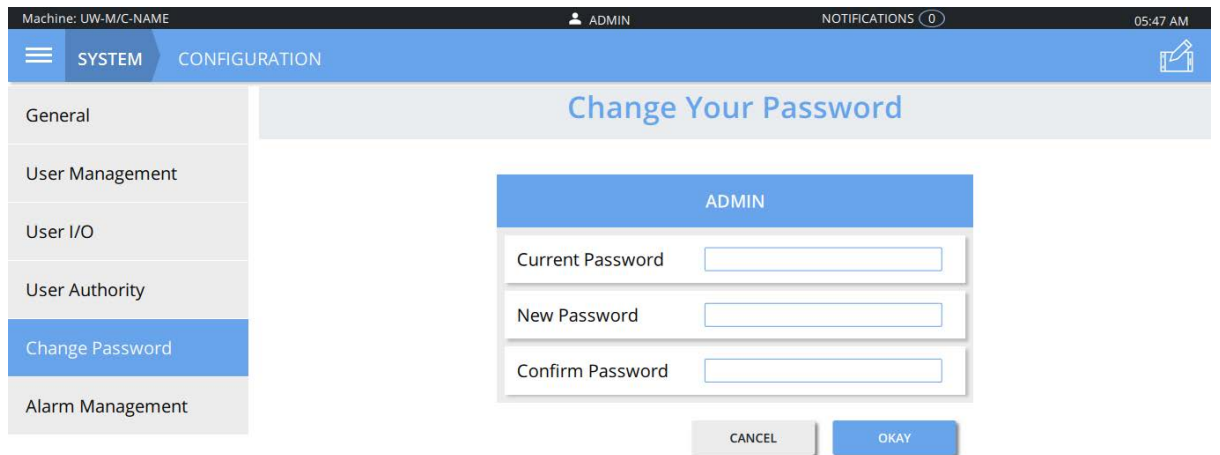
Use this menu to manage and configure alarms.

Figure 5.34 Alarm Management

	Reset Required	Log Alarm	General Alarm
Overloads	<input checked="" type="checkbox"/>	<input checked="" type="checkbox"/>	<input checked="" type="checkbox"/>
Cycle Modified	<input checked="" type="checkbox"/>	<input checked="" type="checkbox"/>	<input checked="" type="checkbox"/>
Warnings	<input checked="" type="checkbox"/>	<input checked="" type="checkbox"/>	<input checked="" type="checkbox"/>
Suspect	<input checked="" type="checkbox"/>	<input checked="" type="checkbox"/>	<input type="checkbox"/>
Reject	<input checked="" type="checkbox"/>	<input checked="" type="checkbox"/>	<input type="checkbox"/>
No Cycle	<input checked="" type="checkbox"/>	<input type="checkbox"/>	<input type="checkbox"/>
Hardware Failure	<input checked="" type="checkbox"/>	<input checked="" type="checkbox"/>	<input checked="" type="checkbox"/>
Non-Cycle Overloads	<input checked="" type="checkbox"/>	<input checked="" type="checkbox"/>	<input type="checkbox"/>

Name	Description
Reset Required	Reset required alarms require a reset before another cycle can start.
Log Alarm	This option determines whether or not the alarm is entered into a log.
General Alarm	If selected, this alarm group will activate the general alarm output, if defined.

5.10.2 Tooling

Future capability coming soon.

Figure 5.35 Tooling

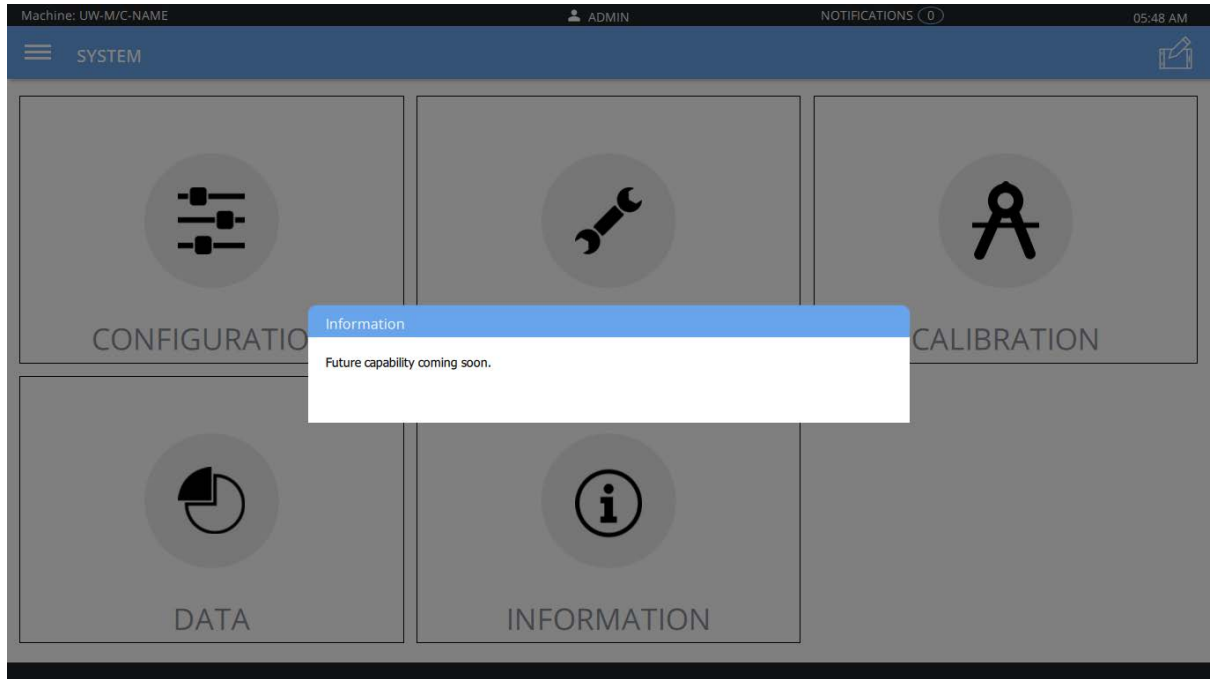

5.10.3 Calibration

The system calibration is set at the factory and should be good for the life of the system. But if you are operating under regulatory requirements, calibrate the system according to their schedule and Branson standards. For more detailed information on calibrating the system, you can contact Branson by calling the Technical Support as indicated on section [7.2 How to Contact Branson](#).

5.10.4 Data

5.10.4.1 Database Optimization Tool

The Database Optimization Tool allows users to clean up the system hard drive for greater storage efficiency. Users are encouraged to use this tool every 1,000,000 welds for optimum system performance.



5.10.4.2 Generate Report

Use this menu to copy weld data, alarm data, system settings, event data, user data, and recipe data in CSV or PDF format to a USB memory stick.

The storage capacity of the memory stick will determine the number of reports the stick can hold.



NOTICE	
	The USB memory stick must be in FAT file system format.
NOTICE	
	A SanDisk Ultra® USB 3.0 Flash Drive is recommended [EDP 1031967 Connectivity Package].

Table 5.13 Generate Report



Step	Action
1	<p>Insert the USB memory stick into the USB port located on the power supply.</p> <p>Figure 5.36 USB port on the GSX-E1 system</p>  <p>Figure 5.37 USB port on the GSX-E1 EtherNet/IP system</p> 
2	<p>Press the <i>Single Report</i> button.</p> 

Table 5.13 Generate Report

Step	Action
3	<p>Select the type of format to be generated and press <i>Next</i>. Available options are:</p> <ul style="list-style-type: none"> • CSV • PDF 
4	<p>Select the storage option and press <i>Next</i>.</p> 

Table 5.13 Generate Report

Step	Action
5	<p>Select the type of data to be generated. Available options are:</p> <p>CSV:</p> <ul style="list-style-type: none"> • Weld Results • Weld Graph <p>PDF:</p> <ul style="list-style-type: none"> • Weld Data • Alarm Data • System Settings • Event Data • User Data • Recipe Data  <p>NOTICE Select the <i>Delete DB Records</i> option to delete the data from the GSX-E1 system after exporting the data to the USB memory stick.</p>
6	<p>Press the <i>Generate Report</i> to generate and export the data to the USB memory stick.</p>  <p>Report is generated successfully</p>

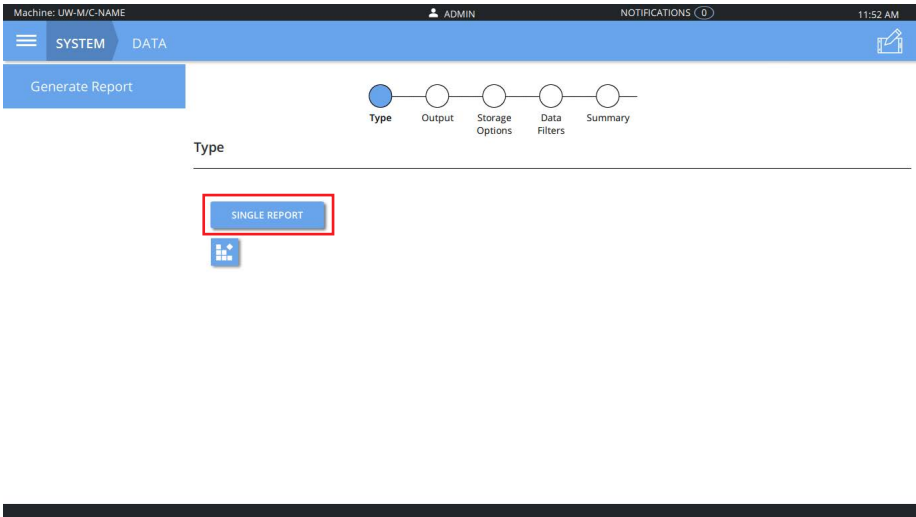
5.10.4.3 Security

Use this menu to enable web service communication, to enable software upgrade over Ethernet, and to upload an authentication key to the GSX-E1 system from a USB memory stick. You can also setup the GSX-E1 system's network settings from this menu.

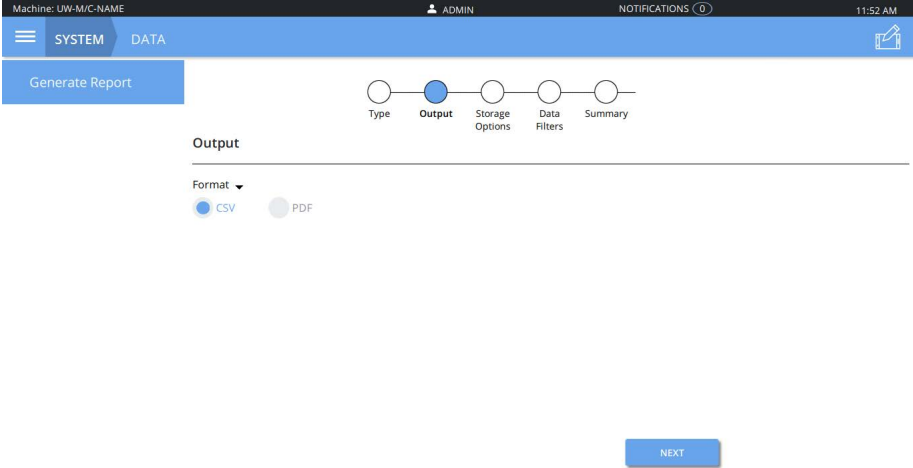
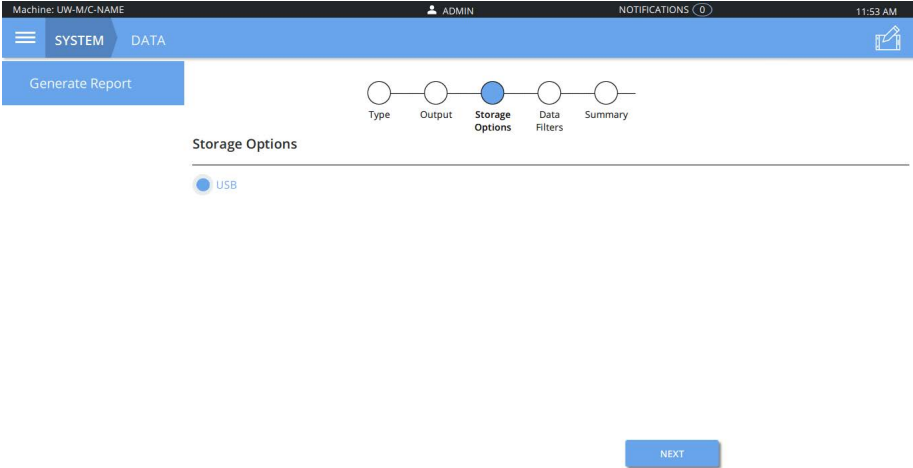
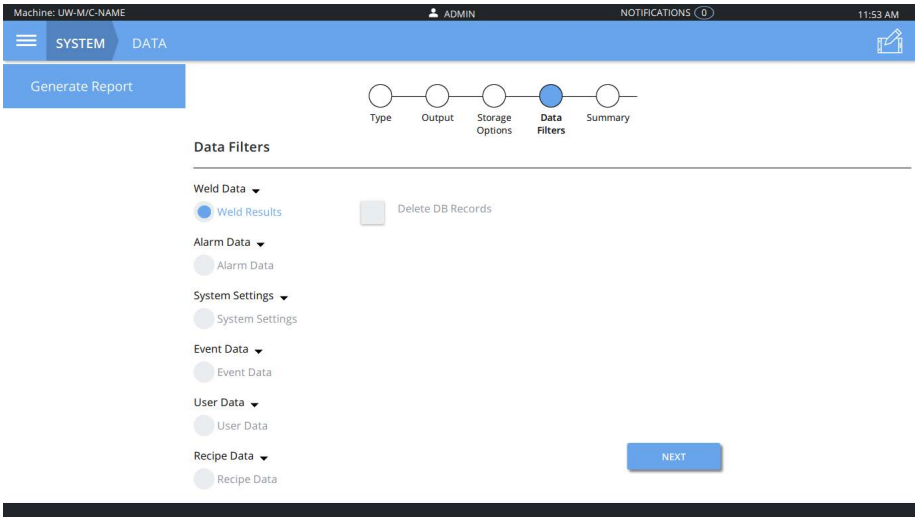
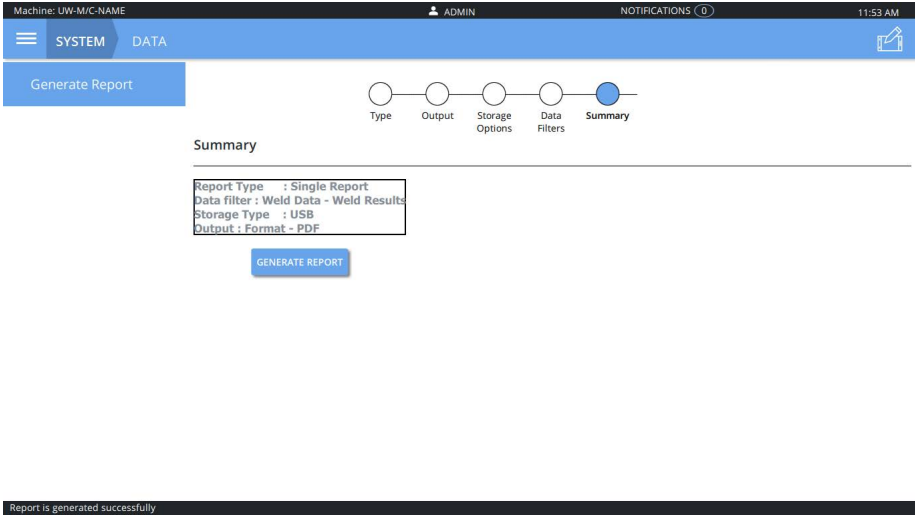
Table 5.14

Name	Description
Enable Web Service Communication	See Appendix D: Web Services for more information.
Authentication Key	See section D.3 Authentication Key for more information.
IP Address	The IP address assigned to the GSX-E1 system.
Subnet Mask	The mask used to determine to what subnet the GSX-E1 system's address belongs to.
Gateway	The gateway address assigned to the network for communication with other computers or networks.

Figure 5.38 Security

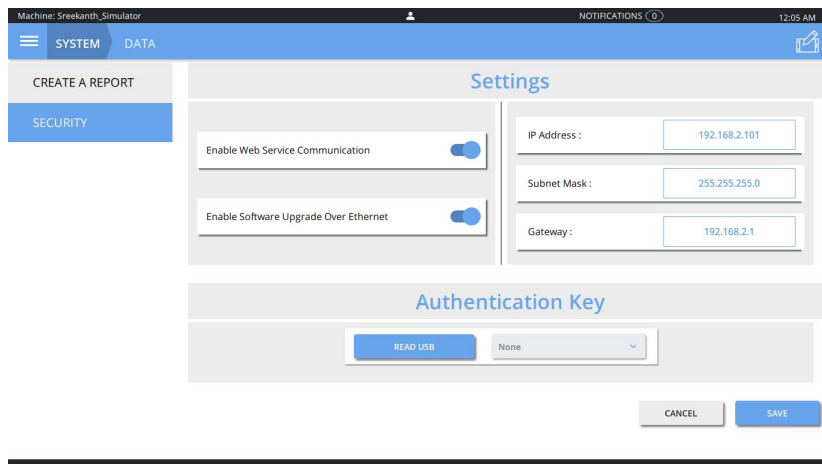

Figure 5.39 Ethernet Port



5.10.4.4 EtherNet/IP Configuration

NOTICE	
	See document BU-4001304 GSX-E1 EtherNet/IP User Guide for more information.

Figure 5.40 EtherNet/IP Settings

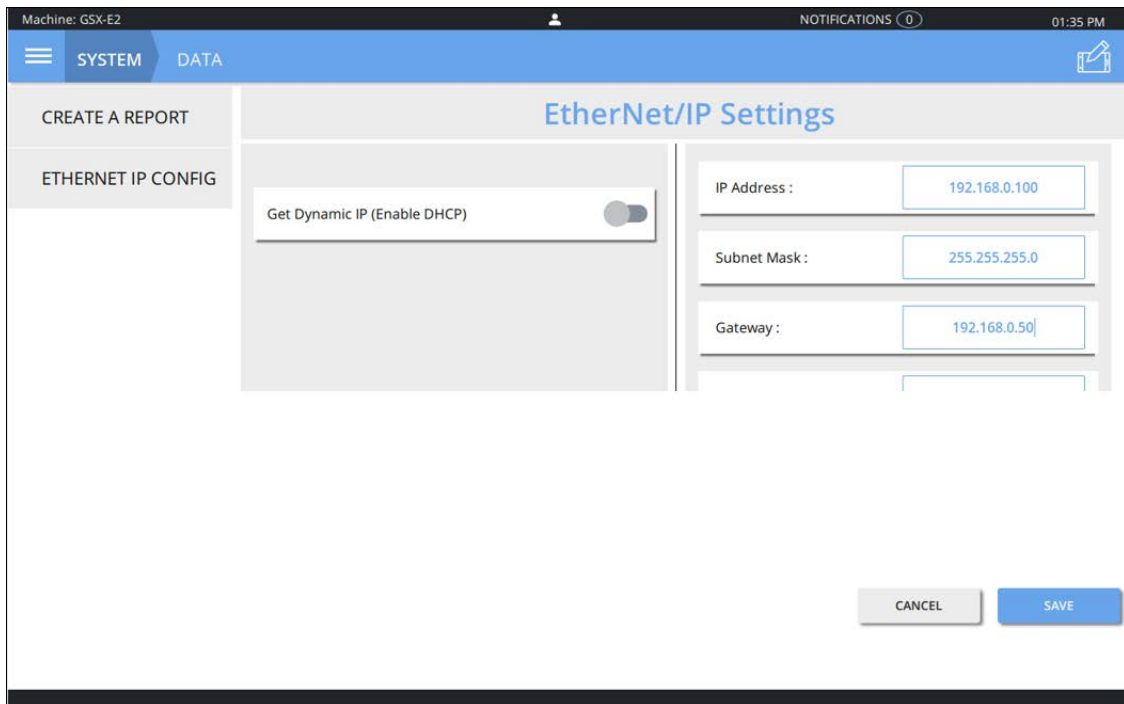

Machine: GSX-E2 NOTIFICATIONS (0) 01:35 PM

SYSTEM DATA

CREATE A REPORT

ETHERNET IP CONFIG

EtherNet/IP Settings

Get Dynamic IP (Enable DHCP)

IP Address : 192.168.0.100

Subnet Mask : 255.255.255.0

Gateway : 192.168.0.50

CANCEL SAVE

5.10.5 Information

5.10.5.1 Machine Details

You can view system details and information about the current setup of your GSX-E1 system from the *Machine Details* screen. Software upgrade can be performed from this screen.

Figure 5.41 Machine Details

Machine: UW-M/C-NAME ADMIN NOTIFICATIONS (0) 05:48 AM

SYSTEM INFORMATION

Machine Details Event Log

Model

General Alarm

Software Versions

UI Controller

Actuator Controller

Supervisory Controller

Power Controller

SOFTWARE UPGRADE

Power Supply

Life Time Welds

PS Type

PS Watt

Overloads

PS Frequency

Actuator

Life time cycles

Calibration Date

Stroke Length

Type

Overloads

Connectivity

MAC ID

Third Party Software Information

Please refer to the following URL for information about third party software (e.g., open source software) used in this product: <https://www.emerson.com/documents/automation/open-source-software-notice-en-us-5317230.pdf>

5.10.5.2 Software Upgrade

NOTICE	
	All USB memory sticks must be removed from the GSX-E1 system before starting the software upgrade procedure.

Table 5.15 Software Upgrade Instructions

Step	Action
1	<p>Log in with your current credentials. Press the Main Menu button on the top left corner and select System.</p> 
2	<p>Press the Information button.</p> 

Table 5.15 Software Upgrade Instructions

Step	Action
3	<p>Press the Software Upgrade button.</p>  <p>The screenshot shows the 'SYSTEM INFORMATION' page with tabs for 'Machine Details' and 'Event Log'. Under 'Machine Details', there are sections for 'Model' (GSXE1), 'General Alarm' (184), 'Software Versions', and 'Power Supply'. The 'SOFTWARE UPGRADE' button is highlighted with a red box.</p>
4	<p>Remove the USB drive from the touchscreen and insert it into one of the USB ports located on the power supply. Press the Read USB button.</p>  <p>The screenshot shows the 'SOFTWARE UPGRADE' dialog box. It contains dropdown menus for 'Actuator Controller' (AC_xxWorks_1.0.4.bin), 'Power Controller' (PC_xxWorks_1.0.4.bin), and 'Supervisory Controller' (SC_xxWorks_1.0.4_20kHz.bin). The 'READ USB' button is highlighted with a red box.</p>
5	<p>Select which controller to upgrade (Actuator, Power, Supervisory). Select only one controller to upgrade. Leave the other two set as None.</p>  <p>The screenshot shows the 'SOFTWARE UPGRADE' dialog box with the 'Actuator Controller' dropdown set to 'None', 'Power Controller' set to 'PC_xxWorks_1.0.4.bin', and 'Supervisory Controller' set to 'None'. The 'UPGRADE' button is visible at the bottom.</p>

Table 5.15 Software Upgrade Instructions

Step	Action
6	<p>Press the Upgrade button to start the software upgrade. Progress will be indicated by a green progress bar. Upgrade takes between 15 to 20 minutes.</p> 
7	<p>Once completed, the following message will appear at the bottom of the dialog box: Upgrade is successful! Please reboot the system.</p> 
8	<p>Repeat steps 5-7 to upgrade the remaining controllers.</p>
9	<p>After software upgrades are complete, close the software upgrade screen by pressing the X on the top right corner.</p> 
10	<p>Set the power supply and auxiliary box circuit breakers to OFF and then to ON.</p>

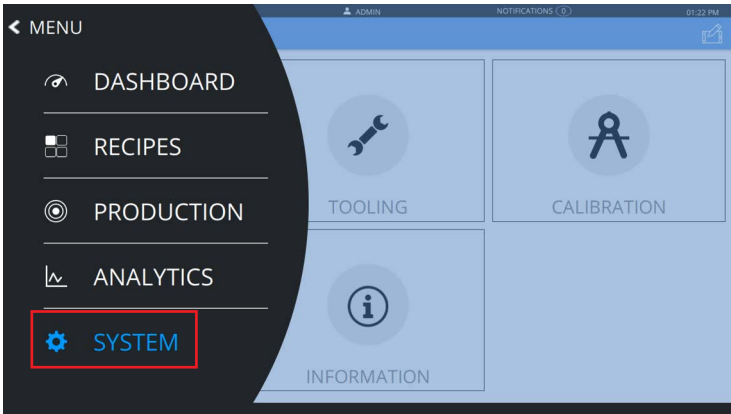
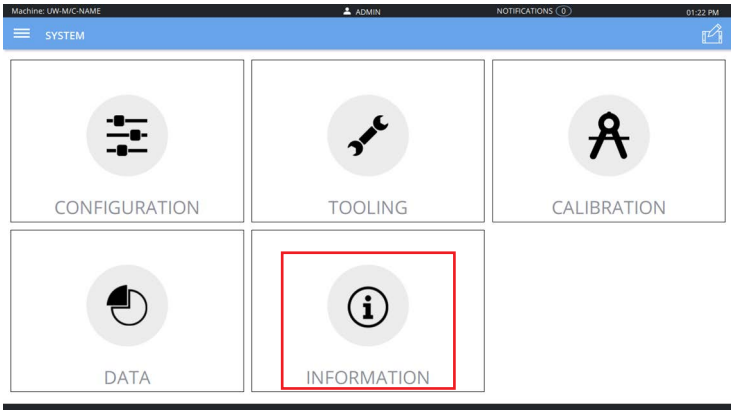
Table 5.15 Software Upgrade Instructions

Step	Action
11	<p>Log in into the system with Administrator credentials. Press the button on the top right corner to open the Action Center.</p> 
12	<p>Press the Power button to close the user interface and return to the Windows interface.</p> 
13	<p>Press the Windows Start Menu button, then go to Windows System and select File Explorer.</p> 

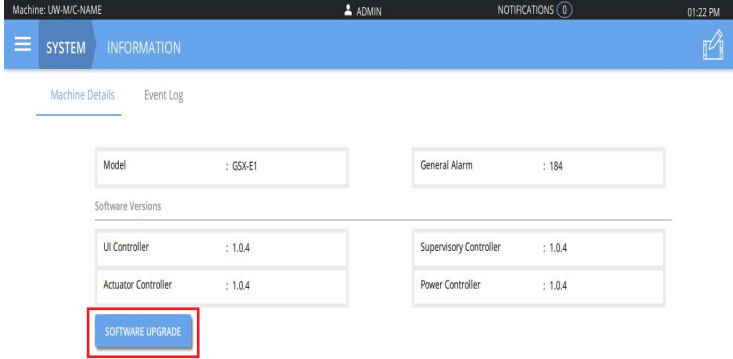
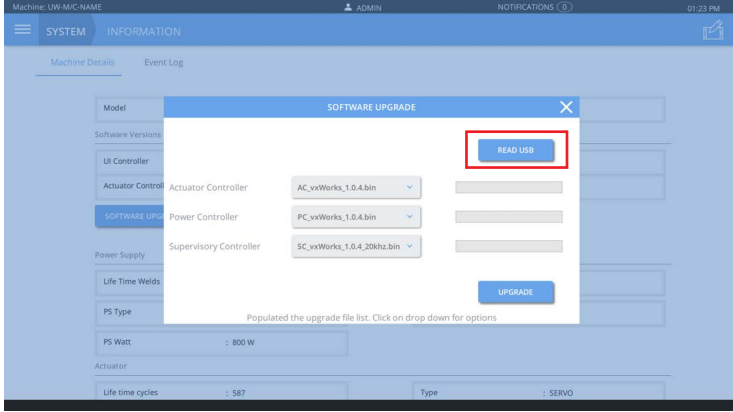
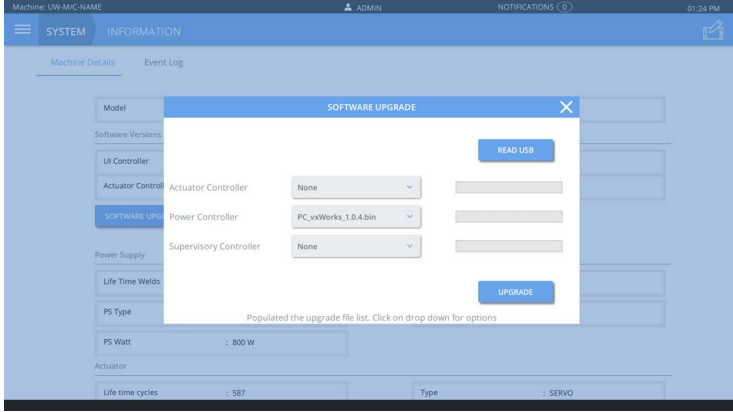
Table 5.15 Software Upgrade Instructions

Step	Action
14	<p>Go to Local Disk C: unit, press and hold down on the UI Controller folder for a couple of seconds. Release your finger to display the right-click context menu and select Delete.</p> 
15	<p>Insert the USB drive with the software upgrade files into one of the USB ports located on the touchscreen. The USB drive will appear on the left side of the File Explorer as Unit D. Select Unit D to display the files on the USB drive.</p> 
16	<p>Press and hold down on the UI Controller folder for a couple of seconds. Release your finger to display the right-click context menu and select Copy.</p> 
17	<p>Go to Local Disk C: unit again. On the file explorer press and hold down on the screen for a couple of seconds. Release your finger to display the right-click context menu and select Paste.</p>

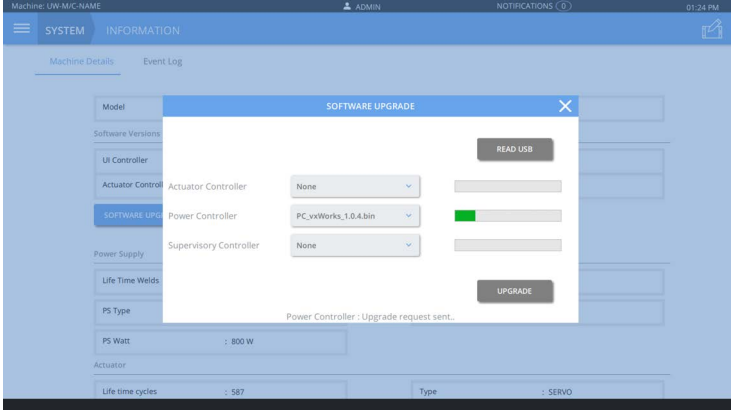
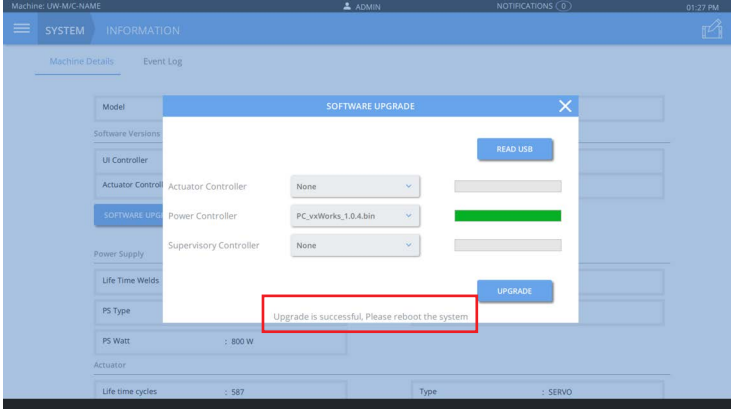
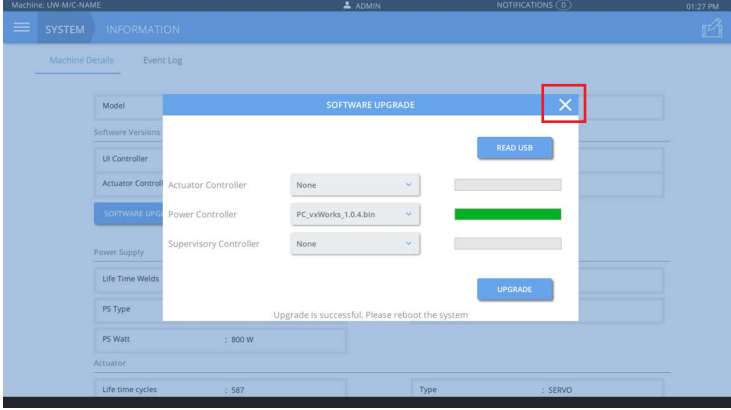
Table 5.15 Software Upgrade Instructions

Step	Action
18	<p>Double tap the UI Controller folder you just pasted. Inside the folder, press and hold down on the UIController file for a couple of seconds. Release your finger to display the right-click context menu and select Create shortcut.</p> 
19	<p>Drag the shortcut to the desktop, replacing the old one. Rename it as GSX-E1.</p>
20	<p>On the desktop, press and hold down on the new GSX-E1 shortcut you just created for a couple of seconds. Release your finger to display the right-click context menu and select Copy.</p>
21	<p>Press the Windows Start menu button and search for RUN, on the dialog box write "shell:startup" and press OK.</p> 
22	<p>On the opened folder press and hold down on the screen for a couple of seconds. Release your finger to display the right-click context menu and select Paste.</p> 
23	<p>This completes the installation process. Reboot your system to initiate normal operation of the GSX-E1 system.</p>

5.10.5.3 Event Log

Displays the event history log. The history log can store up to 100,000 events.

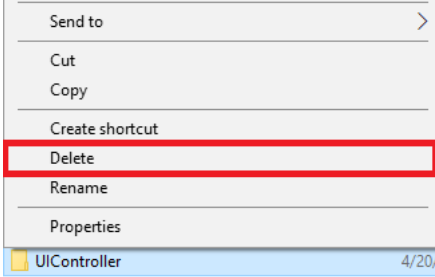
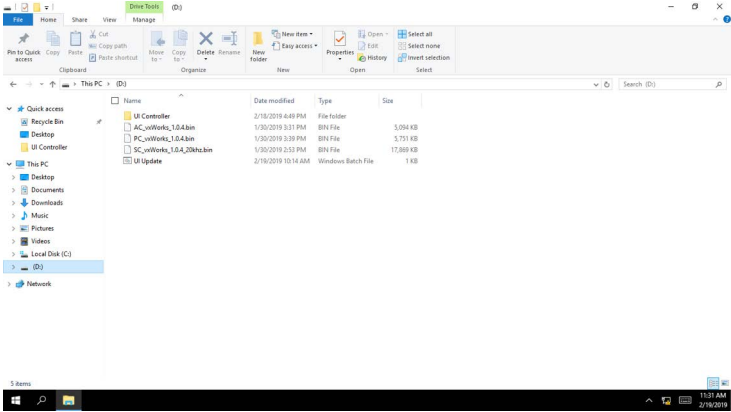
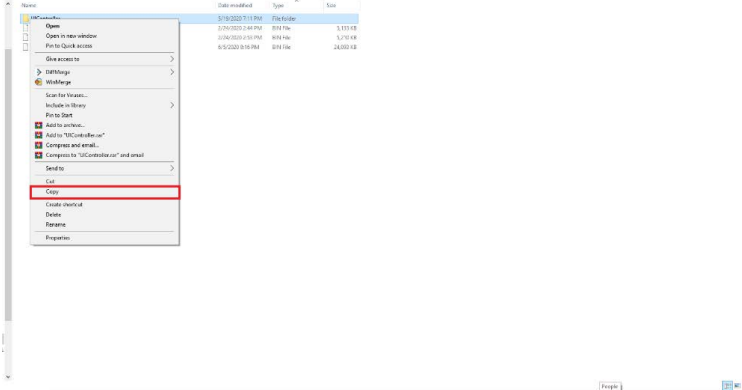
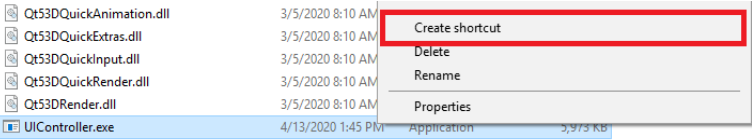
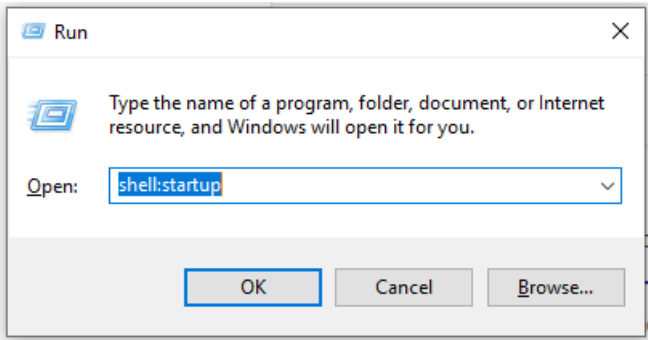
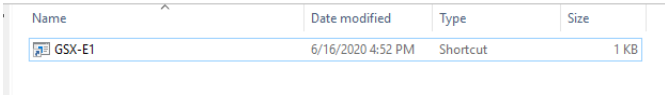
Figure 5.42 Event Log

Event #	Date & Time	Event	User	PS Serial #	Comments
17	2080/10/31 05:41:37	USER LOGIN	ADMIN	Default123	
16	2080/10/31 05:40:56	USER LOGOUT	ADMIN	Default123	
15	2080/10/31 05:38:08	USER LOGIN	ADMIN	Default123	
14	2080/10/31 03:49:02	RECIPE MODIFIED	ADMIN	Default123	
13	2080/10/31 03:24:48	EMERGENCY_STOP_RELEASED	ADMIN	Default123	
12	2080/10/31 03:24:48	EMERGENCY_STOP_PRESSED	ADMIN	Default123	
11	2080/10/31 03:10:43	USER LOGIN	ADMIN	Default123	
10	2080/10/31 02:32:16	EMERGENCY_STOP_RELEASED	ADMIN	Default123	
9	2080/10/31 02:32:15	EMERGENCY_STOP_PRESSED	ADMIN	Default123	
8	2080/10/31 02:28:43	RECIPE MODIFIED	ADMIN	Default123	
7	2080/10/31 02:25:27	RECIPE MODIFIED	ADMIN	Default123	
6	2080/10/31 02:24:25	USER LOGIN	ADMIN	Default123	

Select an event and Press the *More Info* button to see a detailed description for the selected event.

Figure 5.43 Event Log - More Info

Event #	Date & Time	Event	User	PS Serial #	Comments
17	2080/10/31 05:41:37	USER LOGIN	ADMIN	Default123	
16	2080/10/31 05:40:56	USER LOGOUT	ADMIN	Default123	
15	2080/10/31 05:38:08	USER LOGIN	ADMIN	Default123	
14	2080/10/31 03:49:02	RECIPE MODIFIED	ADMIN	Default123	
13	2080/10/31 03:24:48	EMERGENCY_STOP_RELEASED	ADMIN	Default123	
12	2080/10/31 03:24:48	EMERGENCY_STOP_PRESSED	ADMIN	Default123	
11	2080/10/31 03:10:43	USER LOGIN	ADMIN	Default123	
10	2080/10/31 02:32:16	EMERGENCY_STOP_RELEASED	ADMIN	Default123	
9	2080/10/31 02:32:15	EMERGENCY_STOP_PRESSED	ADMIN	Default123	
8	2080/10/31 02:28:43	RECIPE MODIFIED	ADMIN	Default123	
7	2080/10/31 02:25:27	RECIPE MODIFIED	ADMIN	Default123	
6	2080/10/31 02:24:25	USER LOGIN	ADMIN	Default123	

More Information

User : ADMIN Event : USER LOGIN

Date & Time : 2080/10/31 05:41:37 PsSerialNo : Default123

Comment

DONE

5.11 Actuator Setup

Figure 5.44 Actuator Setup

Name	Description
Home	Carriage at top of the actuator. This is the zero position.
Ready Offset	Set the absolute position below the Home position the carriage returns to after a weld and before the next weld.
Find Part Contact	Select to find the part contact position. The part contact position is based on the distance that the horn has to travel from its home position until it touches the part.
Horn Down	Use Horn Down to verify that your fixture is properly set up or to determine the absolute distance that the horn needs to travel to weld your parts. After pressing the Horn Down button you can use the start switches to bring the horn down to the position you have set without ultrasonic energy on. Once the horn is in position, you can release the start switches in order to verify your setup. Horn will only stay down as long as the start switches are held on.
Horn Clamp	Turning the Horn Clamp toggle to on will cause the horn to remain at the workpiece when the a Horn Down is performed. Pressing <i>Retract</i> will bring the horn up.

5.11.1 Advanced Feature

CAUTION	
	Do not change these parameters without guidance of Branson support. See section 7.2 How to Contact Branson for more information.

Figure 5.45 Advanced Feature



Machine: UW-M/C-NAME ADMIN NOTIFICATIONS (0) 05:49 AM

ACTUATOR SETUP ADVANCED FEATURE

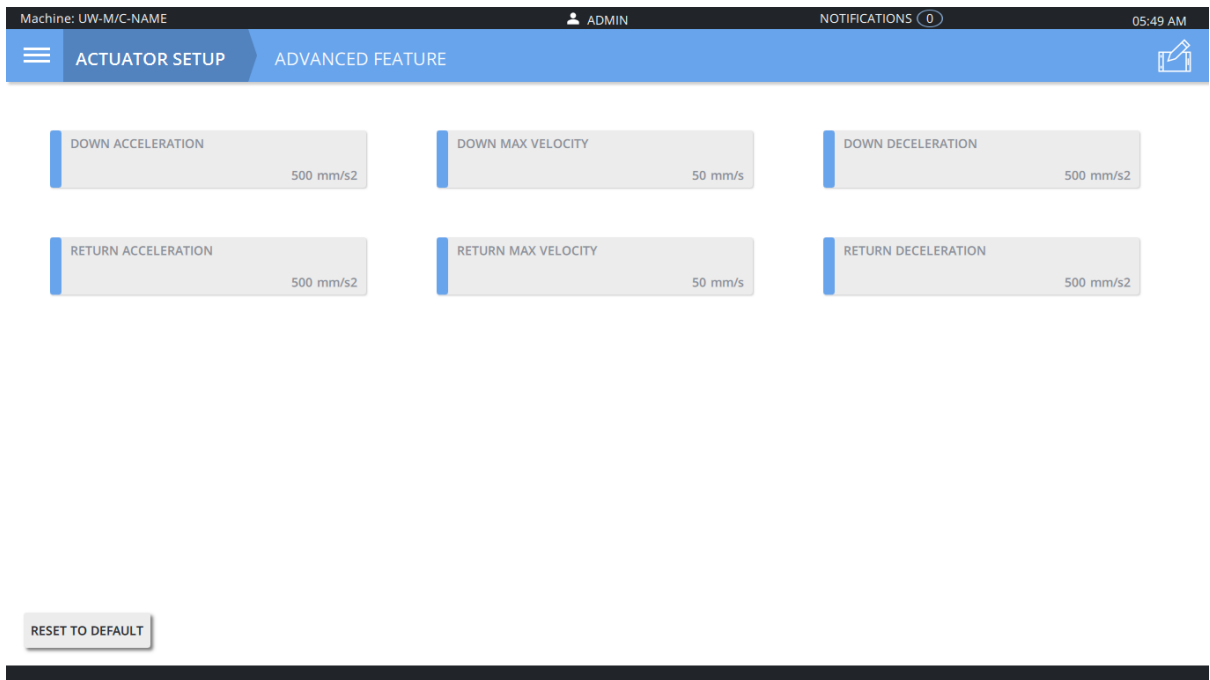
DOWN ACCELERATION 500 mm/s ²	DOWN MAX VELOCITY 50 mm/s	DOWN DECELERATION 500 mm/s ²
RETURN ACCELERATION 500 mm/s ²	RETURN MAX VELOCITY 50 mm/s	RETURN DECELERATION 500 mm/s ²

RESET TO DEFAULT

5.12 Scan/Seek/Test

5.12.1 Scan

Use this menu to diagnose your ultrasonic horn. When performing a horn scan, ideally, there will be only one parallel resonant frequency. The scan graph is provided with 4 available parameters: Amplitude, Current, Phase, Impedance.

Each parameter has a check-box to the left of its name. Only checked parameters will be displayed.

Figure 5.46 Scan

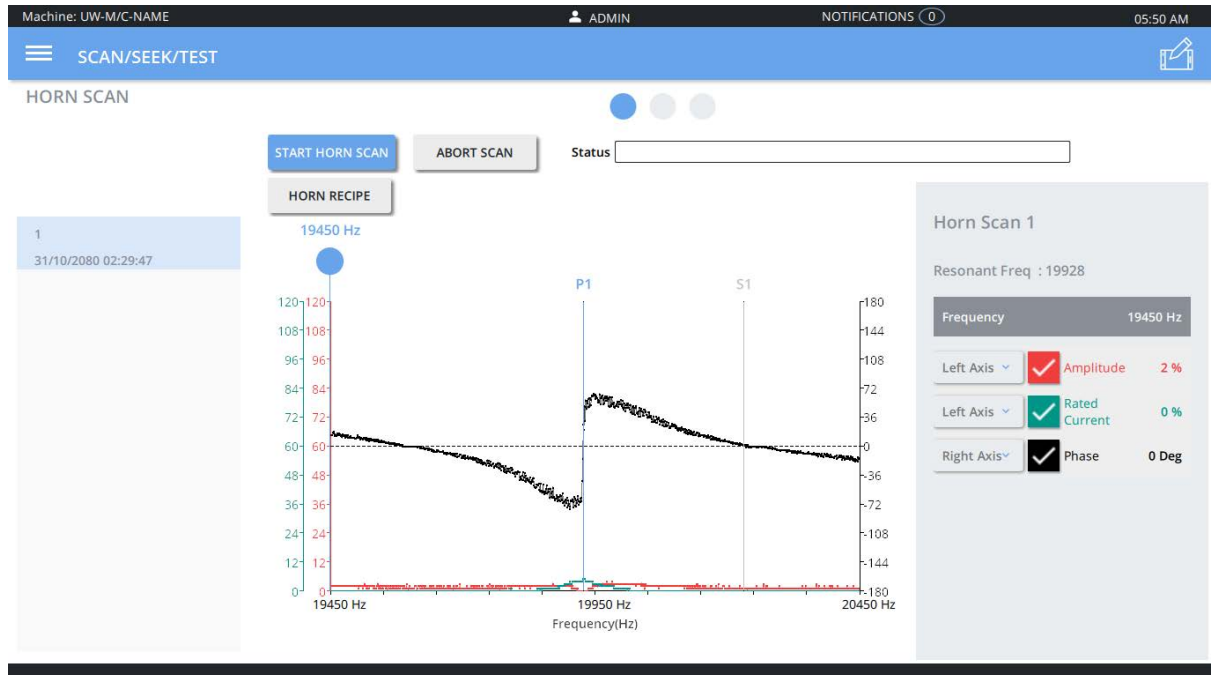

Name	Description
Start Horn Scan	Press to initiate the horn scan.
Abort Scan	Press to abort the horn scan.

5.12.2 Seek

This feature allows you to capture seek data which you can both view and export. The seek data graph is provided with 5 available parameters: Amplitude, Frequency, Power, Current, Phase.

Each parameter has a check-box to the left of its name. Only checked parameters will be displayed.

Figure 5.47 Seek

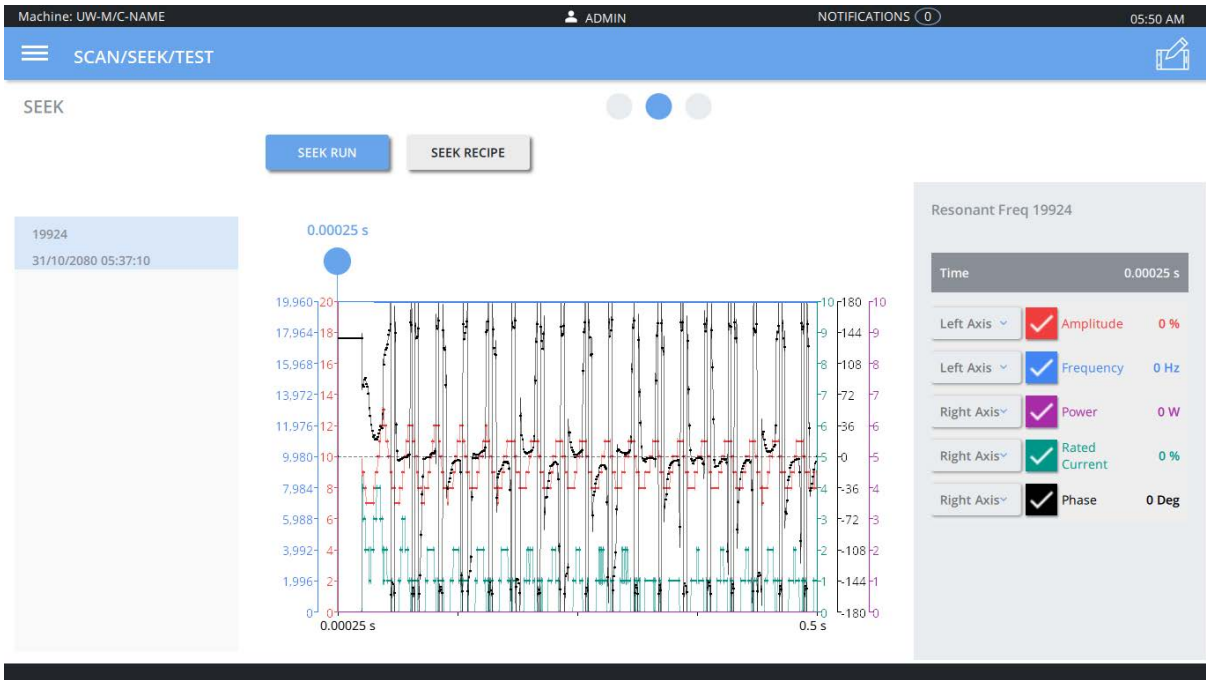

Name	Description
Seek Run	Click to perform a seek cycle.

5.12.3 Ultrasonic Test

Use this menu to test your system. This feature allows you to capture welding data which you can both view and export. The weld data graph is provided with 5 available parameters: Frequency, Amplitude, Power, Current, and Phase.

Each parameter has a check-box to the left of its name. Only checked parameters will be displayed.

Figure 5.48 Ultrasonic Test

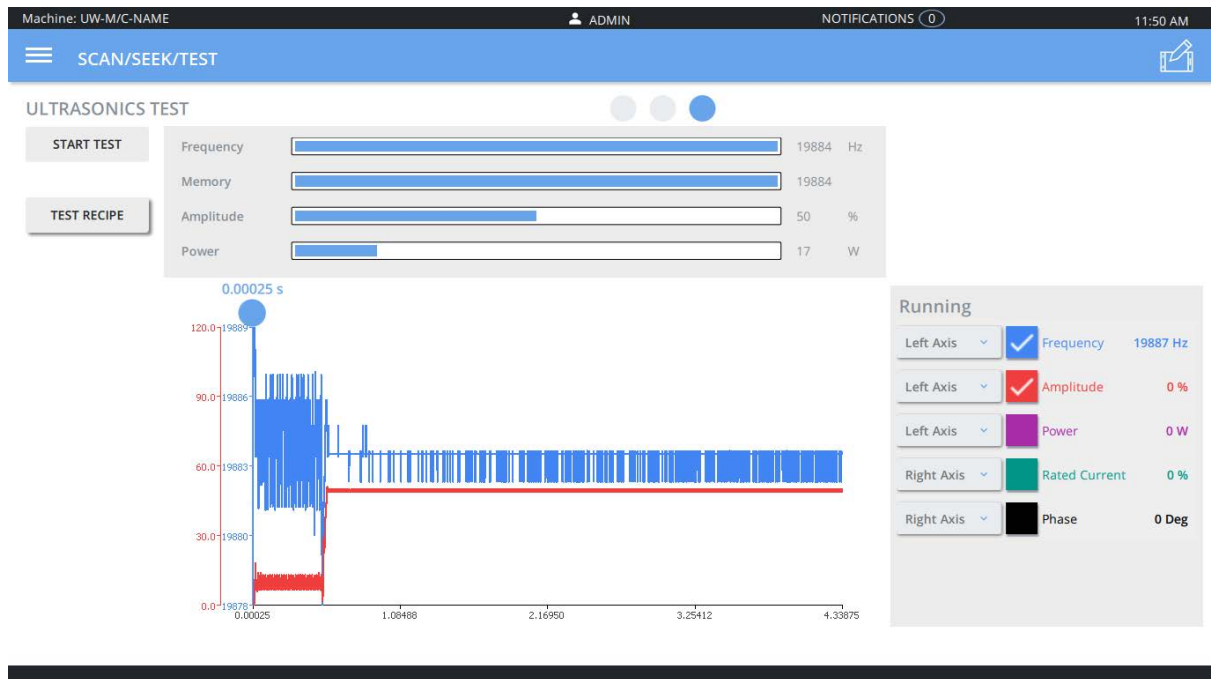

5.13 Optional Dynamic Weld Mode

5.13.1 Description

Optional software package "Elite Precision+" delivers a new patented Dynamic Weld Mode. This software solution is an intelligent and adaptive weld mode that enables the welder with the capability to adjust key parameters in real time which can optimize part quality without external sensors or devices during weld applications such as insertion, staking, swaging and other operations.

Figure 5.49 Dynamic Weld Mode

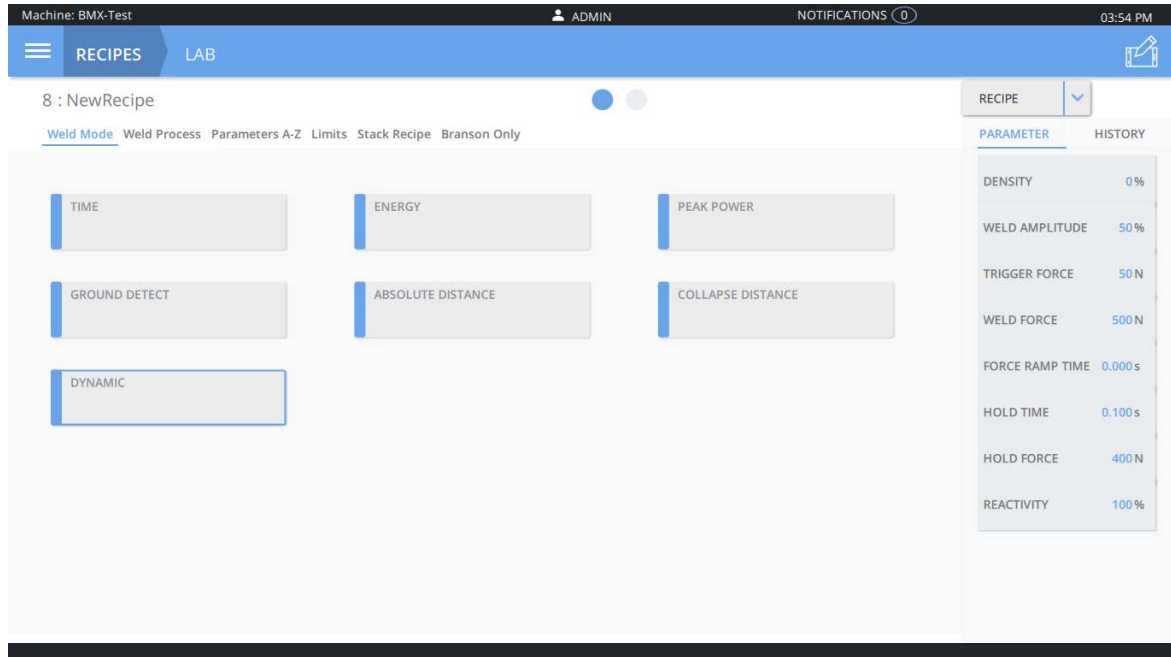

5.13.2 Functionality



User control based on two (2) control variables, Density And Reactivity:

- Density: Value entry (1-100%) that defines material density
- Reactivity: Value entry (1-100%) that defines how quickly the system should get to desired result

Chapter 6: Maintenance

6.1	General Maintenance Considerations	166
6.2	Periodically Clean the Equipment	167
6.3	Electromechanical Actuator Assembly Maintenance	168
6.4	Recondition the Stack (Converter, Booster and Horn)	172
6.5	GSX-E1 Systems, Accessories, Spare Parts & Options	174

6.1 General Maintenance Considerations

NOTICE	
	There are no customer replaceable components inside the system. Have all servicing done by a qualified Branson technician.
NOTICE	
	When performing maintenance on the welder, make sure that no other automated systems are active.
WARNING	
	Use LOTO (Lock Out Tag Out) lockable plug cover over line cord plug during any maintenance.

6.2 Periodically Clean the Equipment

6.2.1 External Covers

External covers may be cleaned with a damp sponge or cloth using a solution of mild soap and water. Do not allow cleaning solution to enter the unit.

To prevent rust in areas of high humidity, exposed steel surfaces, may require a very light film of rust preventing oil.

6.2.2 Touchscreen

When it is necessary to clean the touchscreen, wipe gently with a soft cloth dampened with a mild detergent. Give a final wipe to the entire screen with the soft damp cloth. Under no circumstances should you use solvents or ammonia to clean the screen.

6.3 Electromechanical Actuator Assembly Maintenance

This defines the type of lubricant, the recommended amount and frequency of re-lubrication of all the parts of the actuator that need lubricating.

6.3.1 Recommendations for Assembly and Start-up

1. When mounting the actuator check that the parts to which it is fixed are correctly aligned. This should be done through the complete stroke. NB: Poor alignment will reduce the life of the actuator.
2. The actuator must not move outside its specified stroke (refer to drawings) as this will could result in internal damage. Note that there is no end stop in extended position, in consequence it is mandatory not to move actuator more than specified stroke (50 or 125 mm depending on models) + over-stroke (2 mm at each side of the specified stroke).
3. For longer stroke applications between 100 - 120 mm, use the following steps to complete the setup process:
 - a. Use the jog mode function to slowly move the horn down to the part
 - b. Once the horn has made contact with the part, register the distance shown on the screen
 - c. Touch the Expected Part Contact area within the actuator set up screen and manually enter the distance value
 - d. Proceed to weld parts
4. It is advisable to check that the motor's safety brake and/or the limit switches (if included on the machine) are working correctly before using the actuator.
5. If possible mount the actuator positioned in the center of its stroke. This will simplify the first movements of the actuator (ie. finding in which direction it moves).
6. It is advised to slowly increase the cycle rate of the actuator to allow running in of the internal parts without overheating.

CAUTION



Power to the system needs to be off when greasing the electromechanical actuator assembly.

6.3.2 Tools Needed

6.3.2.1 Nozzle

Snap-in Grease Gun Nozzle Tip

Link: <https://www.mcmaster.com/2906k93>

Figure 6.1 Nozzle



6.3.2.2 Grease Gun

Pistol-Grip Grease Gun

Link: <https://www.mcmaster.com/1190k37>

Figure 6.2 Grease Gun

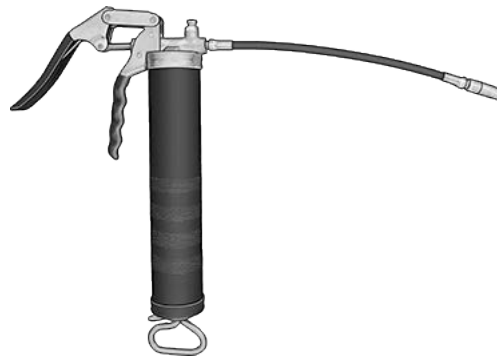

6.3.2.3 Grease

Klüberplex BEM 41-141

Link: <https://www.klueber.com/en/product-detail/id/1817/>

Figure 6.3 Grease



6.3.3 Roller Screw

Type	KLUBERPLEX BEM 41-141
Viscosity	130 cSt at 40°C
	14 cSt at 100°C
NLGI classification	1
Base oil type	Mixed (mineral and synthetic oils)
Supplier:	Klüber
Quantity	2 cm ³ each time
Period	Every 6 months or 3 million cycles (whichever comes first)

Actuator has been delivered with grease nipple aligned with lubrication access. If during assembly on the machine, the push tube has been angularly turned, it has to be returned (half turn).

Figure 6.4 Roller Screw

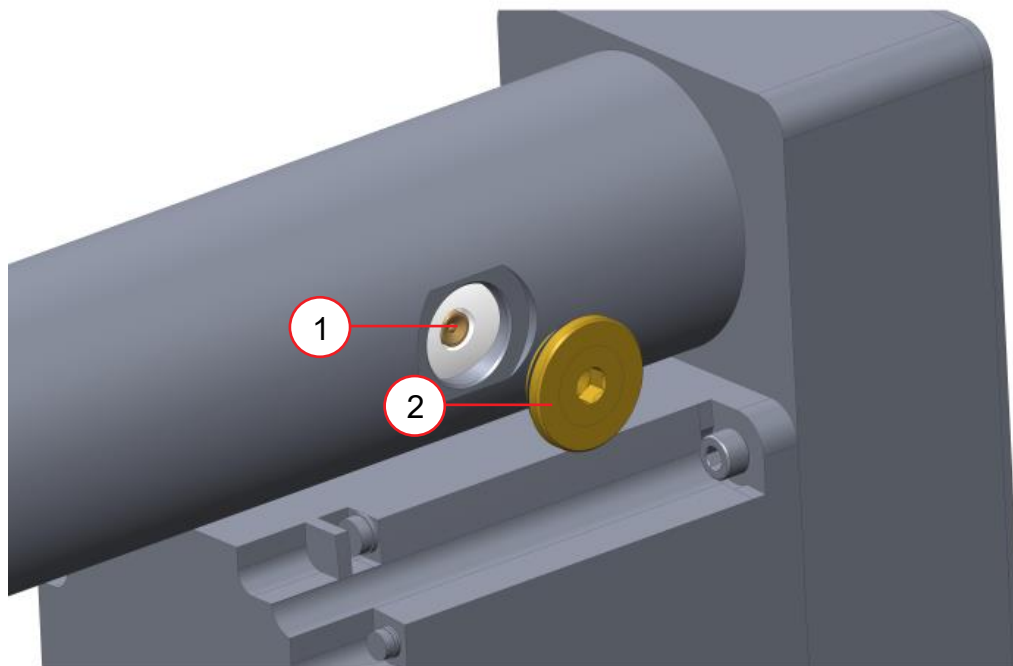

Table 6.1 Roller Screw

Item	Description
1	Grease nipple
2	Plug for lubrication access

Table 6.2 Greasing Procedure

Step	Description
1	Position the actuator at the greasing position – stroke 0 mm (see Figure 6.4).
2	Remove the greasing plug to have access of grease nipple.
3	Inject half the required amount through the grease nipple.
4	Replace the plug.
5	Make ten double strokes along the whole stroke slowly to spread the grease along the screw shaft.
6	Repeat steps 1-5.

Preferably, the recommended lubricant quantity can be applied incrementally in smaller doses throughout the same period, in respect the total quantity of renewal grease does not exceed the amount of grease that has been defined.

This is a closed system. Re-lubrication is most effective only if the old grease is removed. The state of the old grease can thus be seen and the quantity and period of re-lubrication modified to suit the real operating conditions. When re-lubricating the old grease takes up free space in the actuator.

6.3.4 Bearings

The bearings are greased for life. It is not possible to re-lubricate without dismantling them.

6.4 Recondition the Stack (Converter, Booster and Horn)

NOTICE	
	<p>Never clean the converter-booster-horn stack mating surfaces by using a buffing wheel or by filing.</p>

Welding system components work most efficiently when the converter-booster-horn stack mating surfaces are flat, in solid contact, and free from fretting corrosion. Poor contact between mating surfaces wastes power output, makes tuning difficult, increases noise and heat, and may cause damage to the converter.

For standard 20 kHz and 30 kHz products, a Branson Mylar polyester film washer should be installed between the horn and booster, and horn and converter. Replace the washer if torn or perforated. Stacks using Mylar plastic film washers should be inspected every three months.

Stacks used with silicone grease, as with certain 20 kHz, 30 kHz and all 40 kHz products, should be periodically reconditioned to eliminate fretting corrosion. A stack using silicone grease should be inspected every two weeks for corrosion. When experience is gained for specific stacks, the inspection interval can be adjusted to a longer or shorter period as required.

6.4.1 Stack Reconditioning Procedure

To recondition stack mating surfaces, take the following steps:

Table 6.3 Stack Reconditioning Procedure

Step	Action
1	Disassemble the converter-booster-horn stack and wipe the mating surfaces with a clean cloth or paper towel.
2	Examine all mating surfaces. If any mating surface shows corrosion or a hard, dark deposit, recondition it.
3	If necessary, remove the threaded stud from the part.
4	Tape a clean sheet of #400 (or finer) grit emery cloth to a clean, smooth, flat surface (such as a sheet of plate glass).
5	Place the interface surface on the emery cloth. Grasp the part at the lower end, with your thumb over the spanner-wrench hole, and lap the part in a straight line across the emery cloth. Do not apply downward pressure — the weight of the part alone provides sufficient pressure.
6	Lap the part, two or three times, in the same direction against the emery cloth.
7	Rotate the part 120 degrees, placing your thumb over the spanner-wrench hole, and repeat the lapping procedure in Step 6.
8	Rotate the part another 120 degrees to the next spanner-wrench hole, and repeat the lapping procedure in Step 6.
9	Re-examine the mating surface. If necessary, repeat Steps 2-5 until you remove most of the contaminant. Remember, this should not require more than two to three complete rotations for an aluminum horn or booster; a titanium component may require more rotations.

Table 6.3 Stack Reconditioning Procedure

Step	Action
10	<p>Before re-inserting a threaded stud in an aluminum booster or horn:</p> <ul style="list-style-type: none"> • Using a file card or wire brush, clean any aluminum bits from the knurled end of the stud. • Using a clean cloth or towel, clean the threaded hole. • Examine the knurled end of the stud. If worn, replace the stud. Also, examine the stud and threaded hole for stripped threads. <p>NOTICE Threaded studs cannot be reused in titanium horns or boosters. Replace all studs in these components.</p>
11	Assemble and install the stack.

6.4.2 Stack Torque Values

Table 6.4 Stack Torque Values

Frequency	Torque
20 kHz	25 N·m
	220 in·lb
30 kHz	21 N·m
	185 in·lb
40 kHz	11 N·m
	95 in·lb

6.5 GSX-E1 Systems, Accessories, Spare Parts & Options

6.5.1 GSX-E1 Systems - V2 Model

Table 6.5 GSX-E1 Systems - V2 Model

Name	Description	EDP
GSX-BT-E1 -20:1.25:L	GSX-E1 System - 20 kHz/1250 W	1035528
GSX-BT-E1 -20:2.5:L	GSX-E1 System - 20 kHz/2500 W	1035529
GSX-BT-E1 -20:4.0:L	GSX-E1 System - 20 kHz/4000 W	1035530
GSX-BT-E1- 30:1.5:L	GSX-E1 System - 30 kHz/1500 W	1035531
GSX-BT-E1 -40:0.8:L	GSX-E1 System - 40 kHz/800 W	1035532

6.5.2 GSX-E1 EtherNet/IP Systems

Table 6.6 GSX-E1 EtherNet/IP Systems

Name	Description	EDP
GSX-E1 EIP 20:1.25 BT	GSX-E1 EtherNet/IP System - 20 kHz/1250 W	1033962
GSX-E1 EIP 20:2.5 BT	GSX-E1 EtherNet/IP System - 20 kHz/2500 W	1033963
GSX-E1 EIP 20:4.0 BT	GSX-E1 EtherNet/IP System - 20 kHz/4000 W	BU-1033964
GSX-E1 EIP 30:1.5 BT	GSX-E1 EtherNet/IP System - 30 kHz/1500 W	1033965
GSX-E1 EIP 40:0.8 BT	GSX-E1 EtherNet/IP System - 40 kHz/800 W	1033966

6.5.3 GSX-E1 Systems - V1 Model

Table 6.7 GSX-E1 Systems - V1 Model

Name	Description	EDP
GSX-BT-E1 -20:1.25:L	GSX-E1 System - 20 kHz/1250 W	1015501
GSX-BT-E1 -20:2.5:L	GSX-E1 System - 20 kHz/2500 W	1015502
GSX-BT-E1 -20:4.0:L	GSX-E1 System - 20 kHz/4000 W	1015503
GSX-BT-E1- 30:1.5:L	GSX-E1 System - 30 kHz/1500 W	1015505
GSX-BT-E1 -40:0.8:L	GSX-E1 System - 40 kHz/800 W	1015507

6.5.4 Converters

Table 6.8 Converters

Description	EDP
CJ20	101-135-059R
CA30	101-135-114R
4TJ	101-135-041R

6.5.5 Boosters

6.5.5.1 20 kHz

Table 6.9 Boosters - 20 kHz

Type of Booster	Description	EDP
Standard Series 1/2-20 Input; 1/20-20 Output 20 kHz	Aluminum, 1:0.6 (Purple)	101-149-055
	Aluminum, 1:1 (Green)	101-149-051
	Aluminum, 1:1.5 (Gold)	101-149-052
	Aluminum, 1:2 (Silver)	101-149-053
	Titanium, 1:0.6 (Purple)	101-149-060
	Titanium, 1:1 (Green)	101-149-056
	Titanium, 1:1.5 (Gold)	101-149-057
	Titanium, 1:2 (Silver)	101-149-058
	Titanium, 1:2.5 (Black)	101-149-059
Solid Mount 1/2-20 Input; 1/20-20 Output 20 kHz	Titanium, 1:0.6 (Purple)	101-149-095
	Titanium, 1:1 (Green)	101-149-096
	Titanium, 1:1.5 (Gold)	101-149-097
	Titanium, 1:2 (Silver)	101-149-098
	Titanium, 1:2.5 (Black)	101-149-099

6.5.5.2 30 kHz

Table 6.10 Boosters - 30 kHz

Type of Booster	Description	EDP
Standard Series 3/8-24 Input; 3/8-24 Output 30 kHz	Titanium, 1:0:6 (Purple)	101-149-124
	Titanium, 1:1 (Green)	101-149-123
	Titanium, 1:1.5 (Gold)	101-149-122
	Titanium, 1:2 (Silver)	101-149-121
	Titanium, 1:2.5 (Black)	101-149-120
Solid Mount 3/8-24 Input; 3/8-24 Output 30 kHz	Titanium, 1:0:6 (Purple)	159-149-142
	Titanium, 1:1 (Green)	159-149-141
	Titanium, 1:1.5 (Gold)	159-149-140
	Titanium, 1:2 (Silver)	159-149-139
	Titanium, 1:2.5 (Black)	159-149-138

6.5.5.3 40 kHz

Table 6.11 Boosters - 40 kHz

Type of Booster	Description	EDP
Standard Series 8 mm 40 kHz	Aluminum, 1:0.6 (Purple)	101-149-087
	Aluminum, 1:1 (Green)	101-149-079
	Aluminum, 1:1.5 (Gold)	101-149-080
	Aluminum, 1:2 (Silver)	101-149-081R
	Aluminum, 1:2.5 (Black)	101-149-082
	Titanium, 1:1 (Green)	101-149-085
	Titanium, 1:1.5 (Gold)	101-149-086
	Titanium, 1:2 (Silver)	101-149-083
	Titanium, 1:2.5 (Black)	101-149-084
Solid Mount 8 mm 40 kHz	Titanium, 1:0:6 (Purple)	109-041-178
	Titanium, 1:1 (Green)	109-041-177
	Titanium, 1:1.5 (Gold)	109-041-176
	Titanium, 1:2 (Silver)	109-041-175
	Titanium, 1:2.5 (Black)	109-041-174

6.5.6 Spare Parts - GSX-E1 - V2 & EtherNet/IP Models

Table 6.12 Spare Parts - GSX-E1 - V2 & EtherNet/IP Models

Name	Description	EDP
Actuator		
GSX-E-Actuator Rear Exit	Elite Precision Series actuator with electro-mechanical actuation.	1035526
GSX-E-Actuator Top Exit		1035527
Auxiliary Box		
Auxiliary Box Rear Exit	Auxiliary Box	1035524
Auxiliary Box Side Exit		1035525
Base/Column		
E Series Base & Column	Elite Precision Series Base & Column	1027619
Power Supply - E1		
GSX-PS-E1 20:1.25 Bottom Exit	GSX-E1 Power Supply - 20 kHz/1250 W	1027599
GSX-PS-E1 20:2.5 Bottom Exit	GSX-E1 Power Supply - 20 kHz/2500 W	1027600
GSX-PS-E1 20:4.0 Bottom Exit	GSX-E1 Power Supply - 20 kHz/4000 W	1027601
GSX-PS-E1 30:1.5 Bottom Exit	GSX-E1 Power Supply - 30 kHz/1500 W	1027602
GSX-PS-E1 40:0.8 Bottom Exit	GSX-E1 Power Supply - 40 kHz/800 W	1027603
GSX-PS-E1 20:1.25 Rear Exit	GSX-E1 Power Supply - 20 kHz/1250 W	1027604
GSX-PS-E1 20:2.5 Rear Exit	GSX-E1 Power Supply - 20 kHz/2500 W	1027605
GSX-PS-E1 20:4.0 Rear Exit	GSX-E1 Power Supply - 20 kHz/4000 W	1027606
GSX-PS-E1 30:1.5 Rear Exit	GSX-E1 Power Supply - 30 kHz/1500 W	1027607
GSX-PS-E1 40:0.8 Rear Exit	GSX-E1 Power Supply - 40 kHz/800 W	1027608

Power Supply - EtherNet/IP

GSX-PS-E1 20:1.25 Bottom Exit	GSX-E1 EtherNet/IP Power Supply - 20 kHz/1250 W	1033777
GSX-PS-E1 20:2.5 Bottom Exit	GSX-E1 EtherNet/IP Power Supply - 20 kHz/2500 W	BU-1033778
GSX-PS-E1 20:4.0 Bottom Exit	GSX-E1 EtherNet/IP Power Supply - 20 kHz/4000 W	1033779
GSX-PS-E1 30:1.5 Bottom Exit	GSX-E1 EtherNet/IP Power Supply - 30 kHz/1500 W	1033780
GSX-PS-E1 40:0.8 Bottom Exit	GSX-E1 EtherNet/IP Power Supply - 40 kHz/800 W	1033781
GSX-PS-E1 20:1.25 Rear Exit	GSX-E1 EtherNet/IP Power Supply - 20 kHz/1250 W	1033782
GSX-PS-E1 20:2.5 Rear Exit	GSX-E1 EtherNet/IP Power Supply - 20 kHz/2500 W	1033783
GSX-PS-E1 20:4.0 Rear Exit	GSX-E1 EtherNet/IP Power Supply - 20 kHz/4000 W	1033784
GSX-PS-E1 30:1.5 Rear Exit	GSX-E1 EtherNet/IP Power Supply - 30 kHz/1500 W	1033785
GSX-PS-E1 40:0.8 Rear Exit	GSX-E1 EtherNet/IP Power Supply - 40 kHz/800 W	BU-1033786

6.5.7 Spare Parts - GSX-E1 - V1 Model

Table 6.13 Spare Parts - GSX-E1 - V1 Model

Name	Description	EDP
Actuator		
GSX-E-Actuator Large	Elite Precision Series actuator with electro-mechanical actuation.	1009622
Auxiliary Box		
Auxiliary Box	Auxiliary Box - 12 V	1026969
Base/Column		
E Series Base & Column	Elite Precision Series base & column.	1012086
Power Supply		
GSX-PS-E1 20:1.25	GSX-E1 Power Supply - 20 kHz/1250 W	1015677
GSX-PS-E1 20:2.5	GSX-E1 Power Supply - 20 kHz/2500 W	1015678
GSX-PS-E1 20:4.0	GSX-E1 Power Supply - 20 kHz/4000 W	1015679
GSX-PS-E1 30:0.75	GSX-E1 Power Supply - 30 kHz/750 W	1015680
GSX-PS-E1 30:1.5	GSX-E1 Power Supply - 30 kHz/1500 W	1015681
GSX-PS-E1 40:0.8	GSX-E1 Power Supply - 40 kHz/800 W	1015683

6.5.8 GSX-E1 System Options

Table 6.14 GSX-E1 System Options

Name	Description	EDP
Warranty		
Extended Warranty	6 months	800-101-006
	12 months	800-101-012
	18 months	800-101-024
Cables		
Ground Detect Cable	2.5 m	1018466
	7.5 m	1018467
	15 m	1018468
Power Supply I/O Cable	2.5 m	1019375
	7.5 m	100-240-392
	15 m	100-240-393
Actuator I/O Cable	2.5 m	1018437
	7.5 m	1018438
	15 m	1018439
User Manuals		
GSX-E1 System User Manual - V2 & EtherNet/IP Models		1032609
GSX-E1 System User Manual - V1 Model		1014910
Other		
12" HMI Display		1030472
GSX-E1 HMI Monitor Arm		1030368
GSX-E1 Standard Leveling Plate		1015704
GSX-E1 Quick Exchange Stack Mount		1017299
Password Recovery Kit		1016041
Connectivity Package		1031967
GSX-E1 Power Supply and Auxiliary Box Mounting Brackets		1030969
GSX-E1 Stainless Steel Actuator Covers		1032397
GSX-E1 Front Bezel Split		1031469

Chapter 7: Support

7.1	Warranty	182
7.2	How to Contact Branson	183

7.1 Warranty

For warranty information please reference the warranty section of Terms and Conditions found at: www.emerson.com/branson-terms-conditions

7.2 How to Contact Branson



We partner with companies of every size and scope to help resolve critical issues. Our global resources and unrivaled technical expertise are available where you need them. Our professionally trained Branson Service Specialists will help you address your needs to maximize productivity — while minimizing any chance of unwanted downtime.

7.2.1 Americas

Table 7.1 Authorized Service Center (Americas)

Name	Address	Tel/Fax Number
CANADA		
Canada Branson Ultrasonics.	66 Leek Crescent Richmond Hill, ON L4B-1H1	T: +1 905 762-3301 F: +1 905-762-3317 www.emerson.com/branson
UNITED STATES		
Headquarters Branson Ultrasonics Corporation	120 Park Ridge Road Brookfield, CT 06804	T: +1 203-796-0400 F: +1 203-796-0450 www.emerson.com/branson
California Branson Ultrasonics Corporation	22693 Old Canal Road Yorba Linda, CA 92887	T: +1 714-637-1029 F: +1 714-637-1046 www.emerson.com/branson
	43272 Christy Street Fremont, CA 94538	T: +1 510-226-8210 www.emerson.com/branson
Georgia Branson Ultrasonics Corporation	1665 Lakes Parkway, Suite 107 Lawrenceville, GA 30043	T: +1 770-962-2111 F: +1 770-962-3720 www.emerson.com/branson
Illinois Branson Ultrasonics Corporation	1585 Barclay Boulevard Buffalo Grove, IL 60089	T: +1 847-229-0800 F: +1 847-229-0861 C: +1 847-989-1564 www.emerson.com/branson

Table 7.1 Authorized Service Center (Americas)

Name	Address	Tel/Fax Number
Massachusetts Branson Ultrasonics Corporation	267 Boston Road, Suite 4 N. Billerica, MA 01862	T: +1 978-262-9040 F: +1 978-262-1494 www.emerson.com/branson
Michigan Branson Ultrasonics Corporation	6590 Sims Drive Sterling Heights, MI 48313	T: +1 586-276-0150 F: +1 586-276-0160 www.emerson.com/branson
Texas Branson Ultrasonics Corporation	4950 Keller Springs Unit 160 Addison, TX 75001	T: +1 972-385-9673 www.emerson.com/branson
MEXICO		
Nuevo Laredo Branson de Mexico S.A. de C.V.	Carretera Nacional Km 8.5 Modulo Industrial America Lote #4 C.P. 88277 Nuevo Laredo, Tamaulipas, Mexico	T: +52 867-711-0810 F: +52 867-711-0811
Monterrey Branson de Mexico S.A. de C.V.	Av. Norte 200 Parque Industrial Kalos C.P. 66600 Monterrey, Nuevo Leon, Mexico	T: +52 81-1332-0261

7.2.2 Europe

Table 7.2 Authorized Service Centers (Europe)

Name	Address	Tel/Fax Number
GERMANY		
Headquarters Branson Ultraschall	Niederlassung der Emerson Technologies GmbH & Co. OHG Waldstrasse 53-55 63128 Dietzenbach, Germany	T: +49 6074-497-0 F: +49 6074-497-199 www.branson.eu
FRANCE		
Rungis Branson Ultrasons	Parc d'affaires Silic 1 Rue des Pyrénées, BP 90404 94573 Rungis Cedex, France	T: +33 (0)1-4180-2550 F: +33 (0)1-4687-8729 www.branson.eu
ITALY		
Milan Branson Ultrasuoni, S.r.l.	Via Dei Lavoratori, 25 20092 Cinisello Balsamo Milano, Italy	T: +39 02-660-8171 F: +39 02-660-10480 www.branson.eu
SLOVAKIA		
Nove Mesto Emerson a.s., Division Branson	Piestanska 1202/44 91528 Nove Mesto Nad Vahom Slovak Republic	T: +421 32-7700-501 F: +421 32-7700-470
SPAIN		
Barcelona Branson Ultrasonidos S.A.E.	C/ Botánica, 131 08908 L'Hospitalet de Llobregat Barcelona, Spain	T: +34 93-586-0500 F: +34 93-588-2258 www.branson.eu
SWITZERLAND		

Table 7.2 Authorized Service Centers (Europe)

Name	Address	Tel/Fax Number
Geneva Branson Ultrasonic SA	9 Chemin du Faubourg-de-Cruseilles CH-1227, Carouge Geneve, Switzerland	T: +41 22-304-83-40
UNITED KINGDOM		
Berkshire Branson Ultrasonics	158 Edinburgh Avenue Slough, Berkshire England SL1 4UE	T: +44 4753-756675 T: +44 1753-756675 F: +44 1753-551270 www.branson.eu

7.2.3 Asia/Pacific

Table 7.3 Authorized Service Centers (Asia/Pacific)

Name	Address	Tel/Fax Number
CHINA		
Headquarters Branson Ultrasonics (Shanghai) Co., Ltd. (China H.Q.)	758 Rong Le Dong Road, Song Jiang Shanghai, PRC, 201613	T: +86 21-3781-9600 F: +86 21-5774-5100 www.branson-china.com
Changzhou Branson Ultrasonics	Room B1206, Hu Tang World Trade Center Wujin District, Changzhou, China	T: +86 189-1753-8535
Chongqing Branson Ultrasonics	Room 5-2403, No.333 Dong Hu South Road, Yu Bei District, Chongqing, China, 401120	T: +86 23-6749-6660 F: +86 23-6749-6660
Dongguan Branson Ultrasonics	Unit B, 4/F, Block 9, Ke Gu Industrial Park No. 6 Zhong Nan Nan Road Shang Sha She Qu, Chang An Town Dongguan, Guangdong, China	T: +86 769-8541-0736 F: +86 769-8541-0735
Tianjin Branson Ultrasonics (Shanghai) Co., Ltd. (Tianjin Office)	Room 103, 5 Gates, Block K2, Haitai Green Industry Base Northwest Side of Sanjing Road and Erwei Road Huayuan Industrial Zone, Tianjin New Industrial Park, China	T: +86 22-8763-0822 F: +86 22-8763-0822
INDIA		
Navi Mumbai Emerson Electric Company (India) Pvt. Ltd. Div. Branson Ultrasonics	Plot A 145/6 , TTC Industrial Area MIDC Kopar Khairne Navi Mumbai - 400 710 Maharashtra India	T: +91 022-6181-6700 T: +91 022-6181-6701 F: +91 22-2768-9088
JAPAN		
Fukuoka Branson Ultrasonics Div. of Emerson Japan Ltd. (Fukuoka Office)	No. 16 Hakata-higashi IR Bldg. 1-3-8 Toko, Hakata Fukuoka, Japan 812-0008	T: +81 92-473-8292 F: +81 92-473-8446 www.branson-jp.com

Table 7.3 Authorized Service Centers (Asia/Pacific)

Name	Address	Tel/Fax Number
Kanagawa Branson Ultrasonics Div. of Emerson Japan Ltd. (Japan H.Q.)	4-3-14 Okada, Atsugi-Shi Kanagawa, Japan, 243-0021	T: +81 46-228-2881 F: +81 46-288-8892 www.branson-jp.com
Nagoya Branson Ultrasonics Div. of Emerson Japan Ltd. (Nagoya Office)	2100 Hattanda Higashi-tanaka, Komaki, Aichi Nagoya, Japan, 485-0826	T: +81 568-41-5411 F: +81 568-41-5410 www.branson-jp.com
Osaka Branson Ultrasonics Div. of Emerson Japan Ltd. (Osaka Office)	3-3-3 Moto-machi, Naniwa Osaka, Japan, 556-0016	T: +81 6-6636-7601 F: +81 6-6636-7602 www.branson-jp.com
Saitama Branson Ultrasonics Div. of Emerson Japan Ltd. (Urawa Office)	2-18-7 Higashiurawa, Midori-ku, Saitama, Japan, 336-0926	T: +81 48 638 1600 F: +81 48 638 1601 www.branson-jp.com
MALAYSIA		
Kuala Lumpur Branson Ultrasonics Div. of Emerson Elec (M) Sdn Bhd.	Clean: No. 11, Jalan TP5A Taman Perindustian Sime UEP 47600 Subang Jaya, Selangor, Malaysia	T: +603 8081-3338 F: +603 8081-5188
Penang Branson Ultrasonics (Penang Office)	No. 1-3-35 Ideal Avenue, Jalan Tun Dr. Awang 11900 Bayan Lepas, Penang, Malaysia	T: +604 641-0276 F: +604 641-0273
SINGAPORE		
Singapore Branson Ultrasonics Div. of Emerson Electric (South Asia) Pte. Ltd.	Blk 4008 Ang Mo Kio Avenue 10 #04-16, TECHPLACE I Singapore 569625	T: +65 6556-1100 F: +65 6455-8459 www.bransonultrasonics.com
SOUTH KOREA		
Gunpo Branson Korea Co. Ltd.	82-20, Bongseong-ro, Gunpo-si Gyeonggi-do, Korea 15850	T: +82 31-422-0631 F: +82 31-422-9572
THAILAND		
Bangkok Emerson (Thailand) Ltd.	662/39-40 Rama 3 Road Bangpongpan, Yannawa Bangkok, Thailand, 10120	T: +66 2-293-0121-7 F: +66 2-293-0129 www.bransonultrasonics.com
Rayong Branson Ultrasonics	100/59-60, Moo 8, Khao Khan Song Sriracha, Chonburi 20110, Thailand	T: +66 2-293-0121 F: +66 2-293-0129

Appendix A: Alarms

A.1	Alarm Categories	188
A.1.1	No Cycle Alarms	189
A.1.2	Hardware Failure Alarms	190
A.1.3	Cycle Modified Alarms	192
A.1.4	Suspect Alarms	193
A.1.5	Reject Alarms	194
A.1.6	Warning Alarms	195
A.1.7	Overload Alarms	196
A.1.8	No Cycle Overload Alarms	197
A.1.9	EN Faults Alarms	198

A.1 Alarm Categories

When the GSX-E1 system encounters a situation that is outside of normal conditions, an alarm is generated. If there is any alarm condition, the HMI displays the name of the alarm and a brief description. Press the Reset button to clear the alarm.

Figure A.1 Alarm

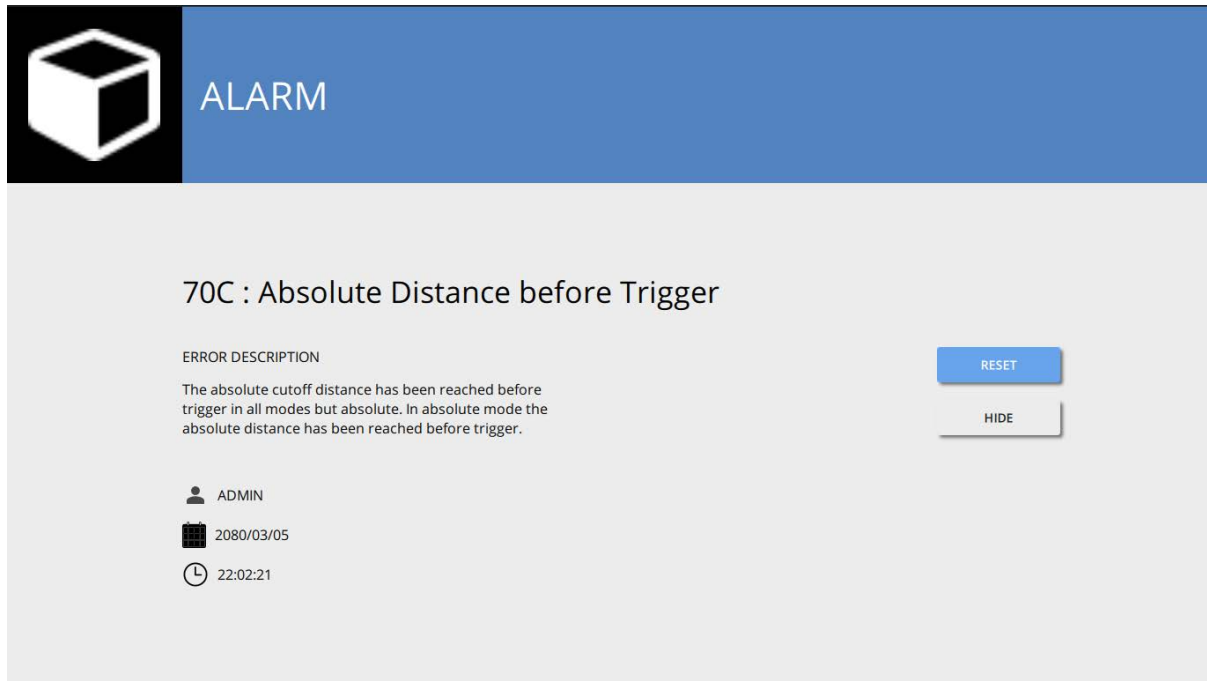

A.1.1 No Cycle Alarms

A No Cycle alarm occurs when the most recent weld cycle was aborted before any weld took place. The specific alarm that has occurred is indicated by the message on the HMI.

Table A.1 No Cycle

Alarm ID	Name	Description
703	External Sonics Delay Timeout	Trigger Delay has been turned on, but the assigned input did not become inactive within the 30 seconds allowed.
706	Part Window Abort	The Missing Part Minimum Distance has not been reached before Trigger occurred or the Maximum Distance has been exceeded before Trigger has occurred.
708	Part Contact before Pretrigger	The Part Contact Distance has been met before the defined Pretrigger Distance.
714	External Tooling Input Lost	The External Tooling Input became inactive before Hold Time ended.
715	External Tooling Input Timeout	The External Tooling Input did not become active within the Tooling Delay Input time after the External Tooling Output became active.
716	Part Present Input Lost	The Part Present Input became inactive before the end of Hold Time.
717	Actuation Drive Error	The Actuator did not reach the target defined position or Actuation is being prevented.
718	Ready Position Timeout	The Actuator did not return to the Ready Position within 4 seconds from end of Hold Time.
719	Recipe Not Valid	The External Recipe # is not valid through the I/O or Barcode scanner.
720	Power Supply Assembly Component Mismatch	The Power Supply Component Name defined in the System Configuration do not match the Name stored with this Recipe.
721	Actuator Assembly Component Mismatch	The Actuator Component Name defined in the System Configuration do not match the Name stored with this Recipe.
722	Stack Assembly Component Mismatch	The Ultrasonic Stack Component Name defined in the System Configuration do not match the Name stored with this Recipe.
70A	External Cycle Abort	The Cycle Abort Digital Input has been activated before trigger occurred.
70C	Invalid Part Contact Distance	The Part Contact Distance is invalid or not set.
71A	Batch Count Complete	The target number of welds for this Batch has been met.\n\nNavigate to the Recipe Production Screen to reset the count.
71B	Active Recipe not Validated	The Operator is attempting to run a recipe that has not been Validated.

A.1.2 Hardware Failure Alarms

Hardware Failure alarms are those which might occur for hardware failure, or hardware disconnected. The specific alarm that has occurred is indicated by the message on the HMI.

Table A.2 Hardware Failure

Alarm ID	Name	Description
601	Start Switch Still Active	The Start Switches are still active 6 seconds after the end of the Cycle.
602	ULS Still Active	The ULS has not become inactive after Trigger or Pretrigger has been reached.
604	ULS Not Active After Homing	The ULS is not active after an E-Stop or Alarm.
605	Ground Detect Before Trigger	The Ground Detect Input has become active before Trigger occurred.
609	Start Switch Lost	The Start Switches became inactive before Trigger occurred.
611	Alarm Log Capacity Reached	Alarm Log Storage is Full.
612	Event Log Capacity Reached	Event Log Storage is Full.
613	Weld Result Capacity Reached	Weld Result Storage is Full.
614	Weld Graph Capacity Reached	Weld Graph Storage is Full.
615	Horn Scan Graph Capacity Reached	Horn Scan Graph Storage is Full.
620	Pretrigger Timeout	Pretrigger has not occurred within 10 seconds of ULS going inactive.
621	Encoder Failure	No distance after part contact is made.
624	Data Error	Corrupted data in the Recipe checked at power up.
625	Actuator Return Timeout	The carriage has not returned home in 4 seconds
626	Actuator NOVRAM	The actuator NOVRAM has corrupted data. This is checked at power up.
627	P/S NOVRAM	The power supply NOVRAM has corrupted data. This is checked at power up.
628	Start Switch Time	Both Start Switches were not pressed within the allowed time frame.
629	Data Storage Full	Internal Storage Device is full. Any operation which requires Data Storage will not be allowed.
62A	Internal Storage Failure	Contact Branson Service for assistance.
62F	Recalibrate Actuator	The force calibration values loaded into the system are invalid.
630	Actuator Clear Function	ULS is active before actuator clear condition was met.
631	External Tooling Active	The External Tooling Input has not become inactive for more than 4 seconds after the end of a cycle.
632	Actuator Type Changed	The actuator type detected at power up is different from power down or after an E-Stop.
633	System Pressure Incorrect	The set air pressure is not achieved.

Table A.2 Hardware Failure

Alarm ID	Name	Description
634	Part Present Active	The Part Present Input is configured and is still active for more than 4 seconds after the end of a cycle.
635	USB Memory Lost	The USB memory stick has been removed or is not functional. Since weld data was configured to be saved on the USB stick welding must be stopped until either the USB stick is functional or weld data is no longer required to be saved.
638	Connection Lost	Communication between the HMI and the welder has been disconnected.
639	Ethernet Link Lost	The Ethernet link has been lost between the Supervisor, actuator, and power supply modules.
63A	Cable Failure	If Cable Detect is configured and the pin goes inactive.
63B	PROFINET or EtherNet/IP not responding	
63C	AC Line Voltage Lost	230 V input to the Power Supply is not ON.
63D	Trigger active in Ready	Trigger force is detected in the Ready State.
63E	HMI Connection Lost	Internal communication failure. Contact Branson Service.
63F	Internal Component Failure	There is an internal failure. Contact Branson Service.
444	RTC Low Battery	System time may not be reliable. Set system time.

A.1.3 Cycle Modified Alarms

A Cycle Modified alarm occurs when the most recent weld cycle has been modified by some event. The specific alarm that has occurred is indicated by the message on the HMI. If you encounter numerous or successive cycle modified alarms, review your weld parameter recipe.

Table A.3 Cycle Modified

Alarm ID	Name	Description
303	Ground Detect Abort	The Ground Detect Input has become active and the Cycle has been aborted.
304	Max Weld Time Exceeded	The maximum time allowed for Ultrasonic energy to be applied to the part has been reached.
306	No Force Step	The force step trigger was not reached.
41B	Peak Power Cutoff	The Peak Power Cutoff value has been exceeded during the weld.
41C	Absolute Distance Cutoff	The Absolute Distance Cutoff value has been exceeded during the weld.
41F	Collapse Distance Cutoff	The Collapse Distance Cutoff value has been exceeded during the weld.
421	Ultrasonics disabled	The Ultrasonics Disable user input has been enabled during this cycle.
426	Frequency Low Cutoff	The Frequency Low Cutoff value has been exceeded during the weld.
427	Frequency High Cutoff	The Frequency High Cutoff value has been exceeded during the weld.
429	Energy Cutoff	The Energy Cutoff value has been exceeded during the weld.
42A	Ground Detect Cutoff	The Ground Detect Cutoff has triggered during the weld.
42B	Time Cutoff	The Time Cutoff value has been exceeded during the weld.

A.1.4 Suspect Alarms

Suspect alarms occurs when the most recent weld cycle fell outside your programmed limits. The specific alarm that has occurred is indicated by the message on the HMI. You should inspect any part that was welded during a cycle that resulted in an alarm. If you encounter numerous or successive alarms you should review your limits parameter recipe.

Table A.4 Suspect

Alarm ID	Name	Description
557	-Absolute Distance Suspect Limit	The total Absolute Distance did not exceed the lower limit value.
558	+Absolute Distance Suspect Limit	The total Absolute Distance exceeded the upper limit value.
555	-Collapse Distance Suspect Limit	The total Collapse Distance did not exceed the lower limit value.
556	+Collapse Distance Suspect Limit	The total Collapse Distance exceeded the upper limit value.
551	-Energy Suspect Limit	The total Weld Energy did not exceed the lower limit value.
552	+Energy Suspect Limit	The total Weld Energy exceeded the upper limit value.
562	-Frequency Suspect Limit	The Weld Frequency did not exceed the lower limit value.
563	+Frequency Suspect Limit	The Weld Frequency exceeded the upper limit value.
553	-Peak Power Suspect Limit	The Peak Power did not exceed the lower limit value.
554	+Peak Power Suspect Limit	The Peak Power exceeded the upper limit value.
55D	-Time Suspect Limit	The total Weld Time did not exceed the lower limit value.
55E	+Time Suspect Limit	The total Weld Time exceeded the upper limit value.
559	-Trigger Distance Suspect Limit	The Trigger Distance did not exceed the lower limit value.
55A	+Trigger Distance Suspect Limit	The Trigger Distance exceeded the upper limit value.
560	-Velocity Suspect Limit	The Weld Velocity did not exceed the lower limit value.
561	+Velocity Suspect Limit	The Weld Velocity exceeded the upper limit value.
55B	-Weld Force Suspect Limit	The total Weld Force did not exceed the lower limit value.
55C	+Weld Force Suspect Limit	The total Weld Force exceeded the upper limit value.

A.1.5 Reject Alarms

Reject alarms occurs when the most recent weld cycle fell outside your programmed limits. The specific alarm that has occurred is indicated by the message on the HMI. You should inspect any part that was welded during a cycle that resulted in an alarm. If you encounter numerous or successive alarms you should review your limits parameter setup

Table A.5 Reject

Alarm ID	Name	Description
50B	-Absolute Distance Reject Limit	The total Absolute Distance did not exceed the lower limit value.
50C	+Absolute Distance Reject Limit	The total Absolute Distance exceeded the upper limit value.
509	-Collapse Distance Reject Limit	The total Collapse Distance did not exceed the lower limit value.
50A	+Collapse Distance Reject Limit	The total Collapse Distance exceeded the upper limit value.
507	-Energy Reject Limit	The total Weld Energy did not exceed the lower limit value.
508	+Energy Reject Limit	The total Weld Energy exceeded the upper limit value.
512	-Frequency Reject Limit	The Weld Frequency did not exceed the lower limit value.
513	+Frequency Reject Limit	The Weld Frequency exceeded the upper limit value.
503	-Peak Power Reject Limit	The Peak Power did not exceed the lower limit value.
504	+Peak Power Reject Limit	The Peak Power exceeded the upper limit value.
514	-Power Match Curve Limit	The Power Match Curve did not exceed the lower limit value.
515	+Power Match Curve Limit	The Power Match Curve exceeded the upper limit value.
505	-Time Reject Limit	The total Weld Time did not exceed the lower limit value.
506	+Time Reject Limit	The total Weld Time exceeded the upper limit value.
50D	-Trigger Reject Limit	The Trigger Distance did not exceed the lower limit value.
50E	+Trigger Reject Limit	The Trigger Distance exceeded the upper limit value.
501	-Velocity Reject Limit	The Weld Velocity did not exceed the lower limit value.
502	+Velocity Reject Limit	The Weld Velocity exceeded the upper limit value.
50F	-Weld Force Reject Limit	The total Weld Force did not exceed the lower limit value.
510	+Weld Force Reject Limit	The total Weld Force exceeded the upper limit value.

A.1.6 Warning Alarms

Table A.6 Warnings

Alarm ID	Name	Description
401	Trigger Force lost in Weld	The applied Force dropped below the minimum Trigger Force during the cycle.
417	Actuator clear not reached	
422	USB Memory Nearly Full (80%)	USB memory is greater than 80% Full. Please consider extracting data to an external storage drive to avoid loss of data.
423	Internal Storage Capacity Warning	Internal Storage is greater than 80% Full. Please consider extracting data to USB to avoid loss of data.
445	Alarm Log Capacity Warning	Alarm Log Storage is greater than 80% Full.
446	Event Log Capacity Warning	Event Log Storage is greater than 80% Full.
447	Weld Result Capacity Warning	Weld Result Storage is greater than 80% Full.
448	Weld Graph Capacity Warning	Weld Graph Storage is greater than 80% Full.
449	Horn Scan Graph Capacity Warning	Horn Scan Graph Storage is greater than 80% Full.
450	Possible Data Error	System Configuration potentially incorrect. Double check the System Information.
41E	Actuator Recalibration suggested	

A.1.7 Overload Alarms

An Overload alarm occurs when the GSX-E1 system has overloaded. The specific overload that has occurred is indicated by the message on the HMI.

Table A.7 Weld Overloads

Alarm ID	Name	Description
001	Weld - Phase Overload	Phase overload occurred during the weld.
002	Weld - Current Overload	Current overload occurred during the weld.
003	Weld - Frequency Overload	Frequency overload occurred during the weld.
004	Weld - Power Overload	Power overload occurred during the weld.
005	Weld - Voltage Overload	Voltage overload occurred during the weld.
006	Weld - Temperature Overload	Temperature overload occurred during the weld.

Table A.8 Energy Brake Overloads

Alarm ID	Name	Description
011	Energy Brake - Phase Overload	Phase overload occurred during Energy Brake.
012	Energy Brake - Current Overload	Current overload occurred during Energy Brake.
013	Energy Brake - Frequency Overload	Frequency overload occurred during Energy Brake.
014	Energy Brake - Power Overload	Power overload occurred during Energy Brake.
015	Energy Brake - Voltage Overload	Voltage overload occurred during Energy Brake.
016	Energy Brake - Temperature Overload	Temperature overload occurred during Energy Brake.

Table A.9 Afterburst Overloads

Alarm ID	Name	Description
021	Afterburst - Phase Overload	Phase overload occurred during Afterburst.
022	Afterburst - Current Overload	Current overload occurred during Afterburst.
023	Afterburst - Frequency Overload	Frequency overload occurred during Afterburst.
024	Afterburst - Power Overload	Power overload occurred during Afterburst.
025	Afterburst - Voltage Overload	Voltage overload occurred during Afterburst.
026	Afterburst - Temperature Overload	Temperature overload occurred during Afterburst.

Table A.10 Post-Weld Seek Overloads

Alarm ID	Name	Description
031	Post-Weld Seek - Phase Overload	Phase overload occurred during Post-Weld Seek.
032	Post-Weld Seek - Current Overload	Current overload occurred during Post-Weld Seek.
033	Post-Weld Seek - Frequency Overload	Frequency overload occurred during Post-Weld Seek.
034	Post-Weld Seek - Power Overload	Power overload occurred during Post-Weld Seek.
035	Post-Weld Seek - Voltage Overload	Voltage overload occurred during Post-Weld Seek.
036	Post-Weld Seek - Temperature Overload	Temperature overload occurred during Post-Weld Seek.

A.1.8 No Cycle Overload Alarms

A No Cycle Overload alarm occurs when the GSX-E1 system has overloaded before trigger or outside the weld cycle.

Table A.11 Test Overloads

Alarm ID	Name	Description
841	Test - Phase Overload	Phase overload occurred during Test.
842	Test - Current Overload	Current overload occurred during Test.
843	Test - Frequency Overload	Frequency overload occurred during Test.
844	Test - Power Overload	Power overload occurred during Test.
845	Test - Voltage Overload	Voltage overload occurred during Test.
846	Test - Temperature Overload	Temperature overload occurred during Test.

Table A.12 Pretrigger Overloads

Alarm ID	Name	Description
851	Pretrigger - Phase Overload	Phase overload occurred during Pretrigger.
852	Pretrigger - Current Overload	Current overload occurred during Pretrigger.
853	Pretrigger - Frequency Overload	Frequency overload occurred during Pretrigger.
854	Pretrigger - Power Overload	Power overload occurred during Pretrigger.
855	Pretrigger - Voltage Overload	Voltage overload occurred during Pretrigger.
856	Pretrigger - Temperature Overload	Temperature overload occurred during Pretrigger.

Table A.13 Seek Overloads

Alarm ID	Name	Description
861	Seek - Phase Overload	Phase overload occurred during Seek.
862	Seek - Current Overload	Current overload occurred during Seek.
863	Seek - Frequency Overload	Frequency overload occurred during Seek.
864	Seek - Power Overload	Power overload occurred during Seek.
865	Seek - Voltage Overload	Voltage overload occurred during Seek.
866	Seek - Temperature Overload	Temperature overload occurred during Seek.

Table A.14 Pre-Weld Seek Overloads

Alarm ID	Name	Description
881	Pre-Weld Seek - Phase Overload	Phase overload occurred during Pre-Weld Seek.
882	Pre-Weld Seek - Current Overload	Current overload occurred during Pre-Weld Seek.
883	Pre-Weld Seek - Frequency Overload	Frequency overload occurred during Pre-Weld Seek.
884	Pre-Weld Seek - Power Overload	Power overload occurred during Pre-Weld Seek.
885	Pre-Weld Seek - Voltage Overload	Voltage overload occurred during Pre-Weld Seek.
886	Pre-Weld Seek - Temperature Overload	Temperature overload occurred during Pre-Weld Seek.

A.1.9 EN Faults Alarms

Table A.15 EN Faults

Alarm ID	Name
EF0	Multiple Faults
EF1	Start Switch Fault
EF2	24 V Fault
EF3	E-Stop Fault
EF4	Linear Encoder Fault
EF5	S-Beam Fault
EF6	Trigger Switch Fault
EF7	Drive Fault
EF8	Cross Monitoring Fault
EF9	Logic Unit Fault
EFA	Sonics Enable Fault

Appendix B: Timing Diagrams

B.1	State Timing Diagrams	200
B.2	Output Timing Diagrams	201
B.3	I/O Timing Diagrams.....	202
B.4	Home & Ready Position Timing Diagrams	205

B.1 State Timing Diagrams

B.1.1 Weld Cycle With No Alarms

The sequence below is for a weld cycle with no alarms. If an alarm occurred, the AlarmST would be executed waiting for the alarm to be reset.

Figure B.1 Weld Cycle With No Alarms

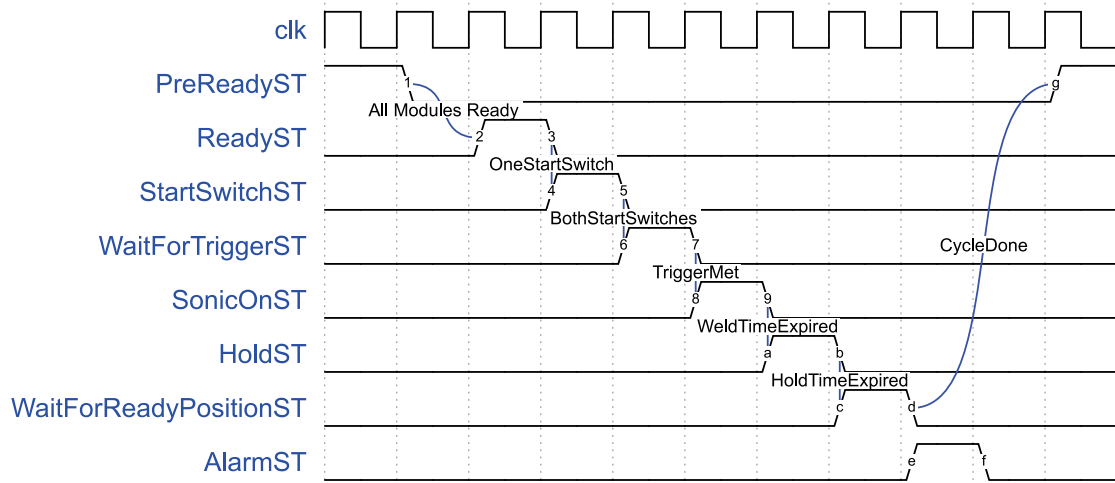

B.2 Output Timing Diagrams

B.2.1 PBRelease, U/S On and Cycle Running Outputs

PBRelease goes active when trigger is met. It goes inactive during PreReadyST.

U/S On goes active when ultrasonics is on.

Cycle Running goes active when exiting ReadyST once the start switches are pressed. It goes inactive when returning to ReadyST or an alarm has occurred.

Cycle OK goes active when entering ready if the previous weld cycle has no alarms.

Figure B.2 PBRelease, U/S On and Cycle Running Outputs

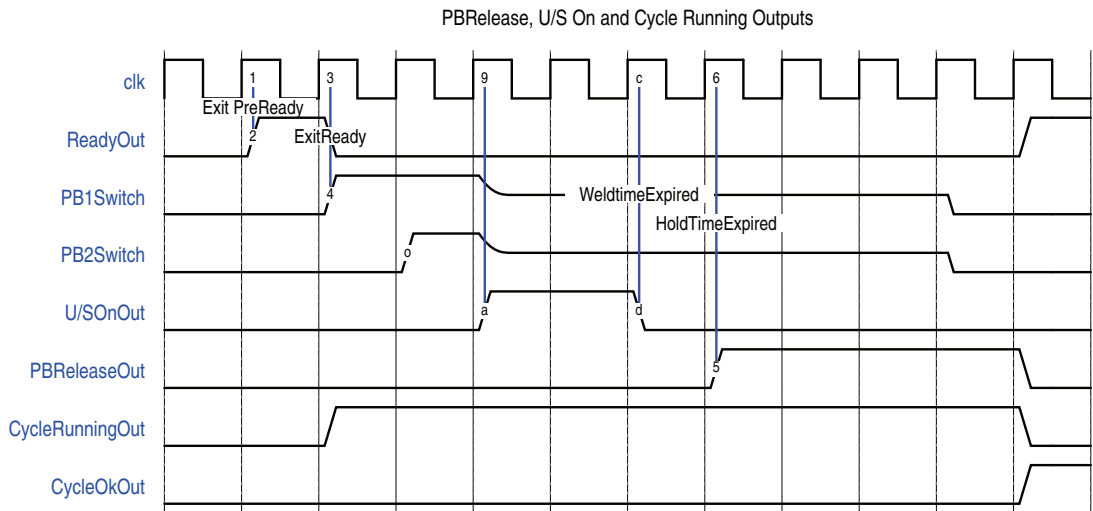

B.3 I/O Timing Diagrams

B.3.1 Part Present Input & Ready Output

If the Part Present in is configured the system will not go to ready until the Part Present signal goes active. Then the system will go to ready and will be able to run a weld cycle.

Ready Output goes active once the Part Present is detected. Ready Output goes inactive once the start switches are pressed.

Figure B.3 Part Present Input & Ready Output

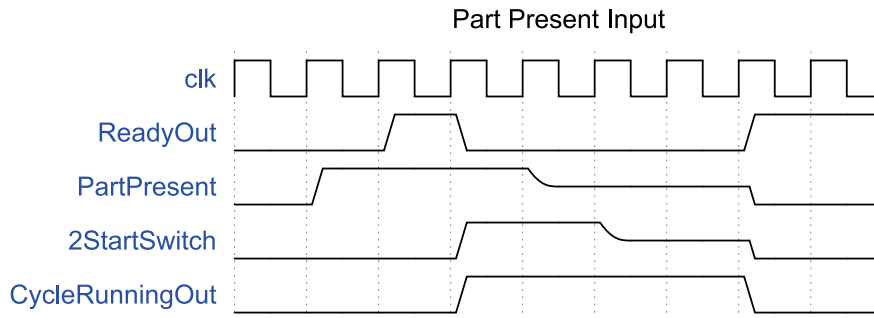

B.3.2 U/S Disable & Reset Input

If U/S Disable is configured, the system will not turn on ultrasonics. The system will be able to run a weld cycle but there will be a warning alarm generated. If General Alarm output is configured it will go active at the end of the weld cycle.

General Alarm output will remain active until a Reset input is received or when you enter the ready state when reset is not required.

Figure B.4 U/S Disable & Reset Input

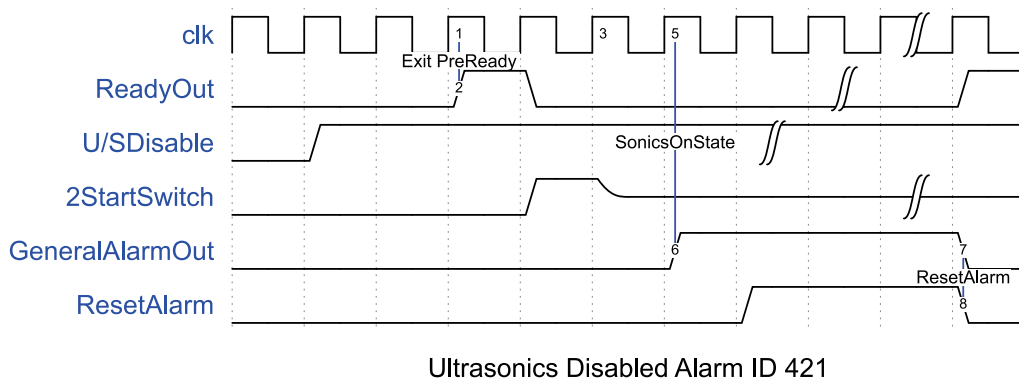

B.3.3 Cycle Abort Input

When Cycle Abort goes active, the weld cycle is terminated. If General Alarm output is configured it will also go active.

General Alarm output will remain active until a Reset input is received or when you enter the ready state when reset is not required.

Figure B.5 Cycle Abort Input

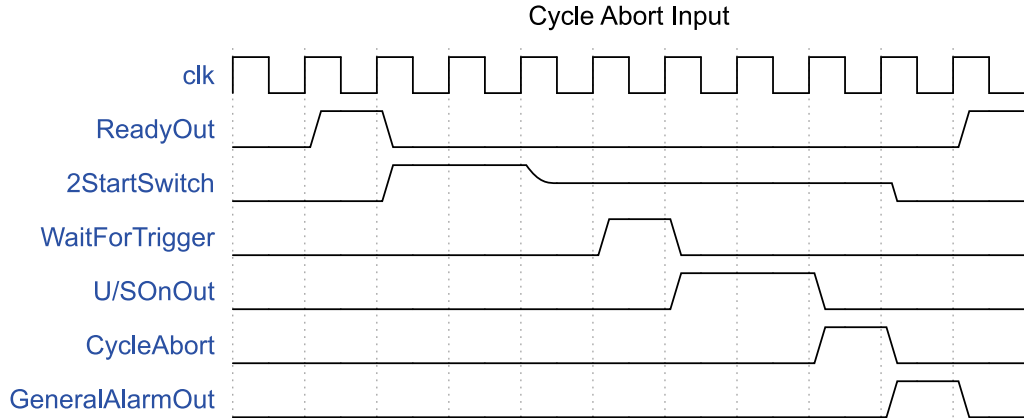

B.3.4 Reject Output

The Reject Alarm is checked after the WeldST. If a Reject Limit alarm occurred, the Reject Alarm output and general alarm output will go active.

They will remain active until a Reset input is received or when you enter the ReadyST when reset is not required.

Figure B.6 Reject Output

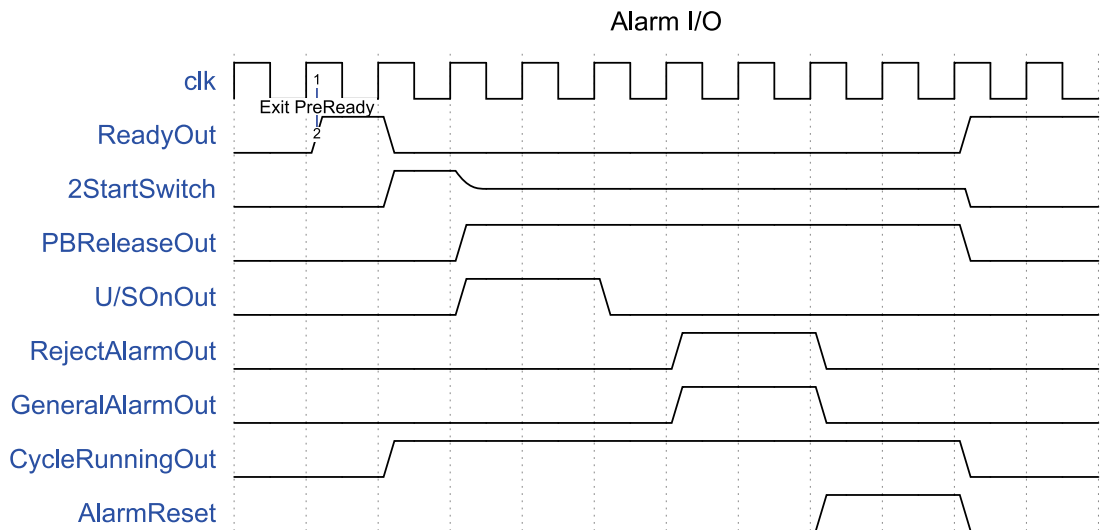

B.3.5 Hold Delay Input

If the Hold Input is configured, hold will not be terminated at the end of Hold Time until the Hold Input is received.

Figure B.7 Hold Delay Input

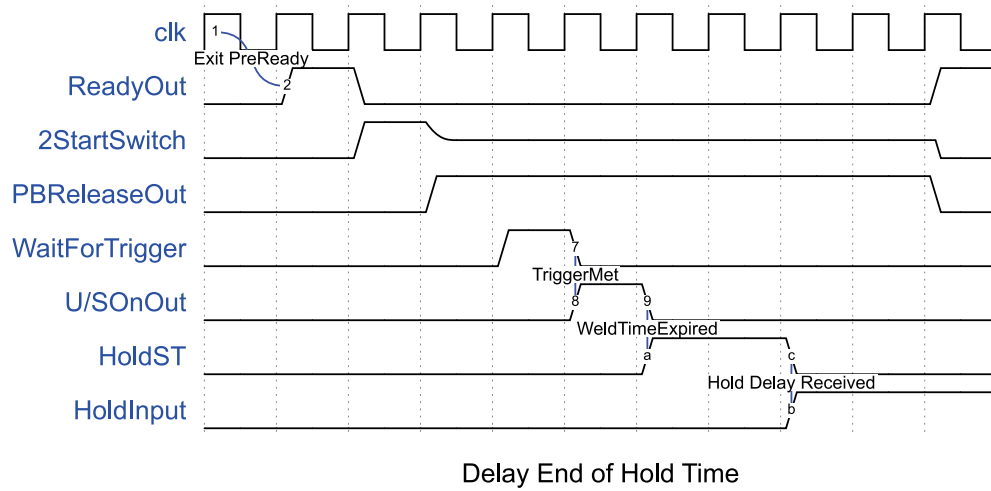

B.4 Home & Ready Position Timing Diagrams

B.4.1 Actuator Starts in Ready Position

1. *ReadyOut* must be active
2. Set the *Go to Home Position* input active
3. Activate start switches
4. When *Home Position* output is active, deactivate start switches
5. The *Go to Home Position* must be deactivated for the system to go back to *Ready*

NOTICE	
	<p>There are no alarms if you do not deactivate the <i>Go to Home Position</i>. Inputs and outputs must be valid for a minimum of 5 ms.</p>

Figure B.8 Actuator Starts in Ready Position



B.4.2 Actuator Starts in Home Position

1. *ReadyOut* must be active
2. Set *Go to Ready Position* input active
3. Activate start switches
4. When *Ready Position* output is active, deactivate start switches
5. The *Go to Ready Position* must be deactivated for the system to go back to *Ready*

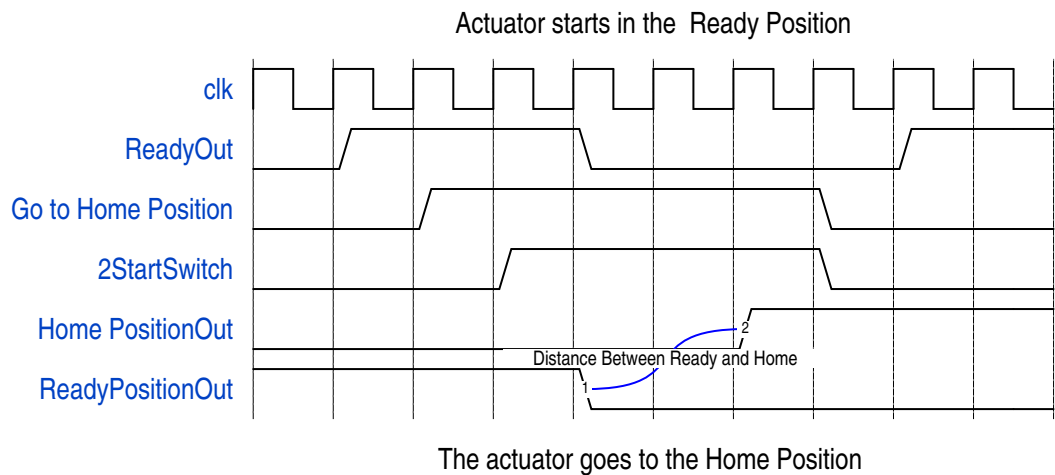
NOTICE	
	<p>There are no alarms if you do not deactivate the <i>Ready Position</i>. Inputs and Outputs must be valid for a minimum of 5 ms.</p>

Figure B.9 Actuator Starts in Home Position



Appendix C: System Automation

C.1	GSX-E1 Automation Guide	208
C.2	GSX-E1 EtherNet/IP Automation Guide	209

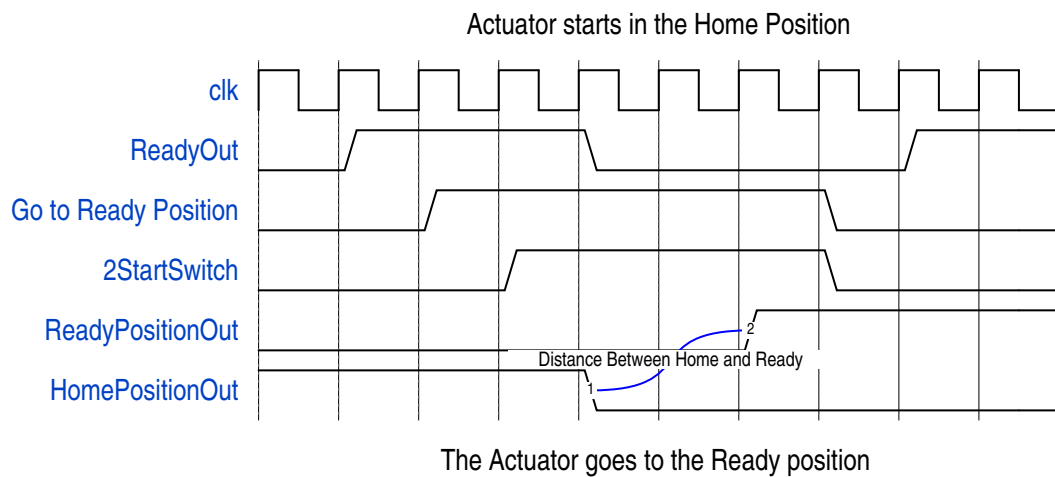
C.1 GSX-E1 Automation Guide

NOTICE



See document **1032610 GSX-E1 V2 Automation User Guide** for more information.

C.2 GSX-E1 EtherNet/IP Automation Guide

NOTICE



See document **BU-4001182 GSX-E1 EtherNet/IP Automation User Guide** for more information.

[This page intentionally left blank]

Appendix D: Web Services

D.1	Overview	212
D.2	Enable Web Service Communication	213
D.3	Authentication Key	214
D.4	Command List	216
D.5	HTTPS Support.	234

D.1 Overview

D.1.1 Introduction

The GSX-E1 System Web Services provide functionality to access the system through Java Script Object Notation (JSON) web requests. This web access encompasses practically every aspect of the GSX-E1 system features; from modifying and reading recipes to configuring hardware and getting access to the internal logs of the system. In addition to that, the web service interface offers fully functional login/logout capability that can allow the client to remotely do anything that can be done from the HMI.

This document gives the details of the web service implementation and interface to the GSX-E1 system. It also gives the details of JSON Service URLs and the data format required by the client to implement custom software for the interface. Lastly, this document provides examples of server/client interaction with details of the data to be expected.

NOTICE	
	For security purposes, communications should use SSL protocol via Ethernet.

NOTICE	
	Users can be logged-in into the GSX system via HMI and Web Services at the same time.

D.1.2 Service URL

The GSX-E1 system has a built-in web server that can handle various web requests. In order to provide the web service functionality, the URL string that is to be sent to the system to initiate the service is of the form:

`https://<GSX-E1 System IP Address>/Services/<Service Name>`

Where the <GSX-E1 System IP Address> is the IP Address found on the *Data > Security* screen and the <Service Name> is the feature you wish to exploit. See section [5.10.4.3 Security](#) for details.

Figure D.1 Ethernet Port

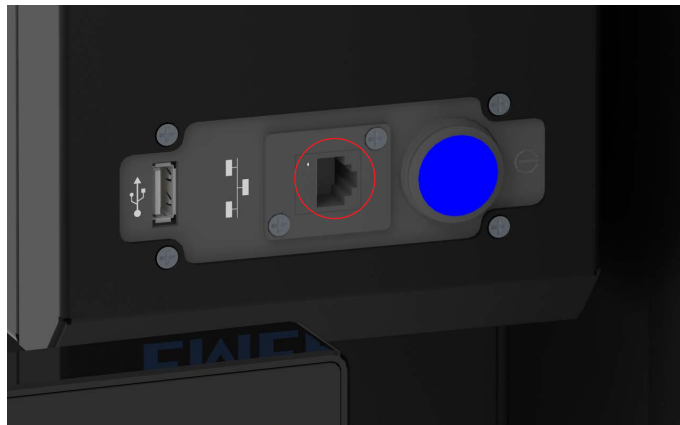

D.2 Enable Web Service Communication

To enable web service communication, press the Main Menu button and navigate to *System > Data > Security*. Turn on the *Enable Web Service Communication* toggle to enable the functionality.



NOTICE	
	<p>GSX IP address must match the host computer network.</p> <p>Example: If the IP address of the host computer is 240.172.80.159, the GSX IP address must be set to 240.172.80.160</p>

Figure D.2 Web Service Communication Toggle

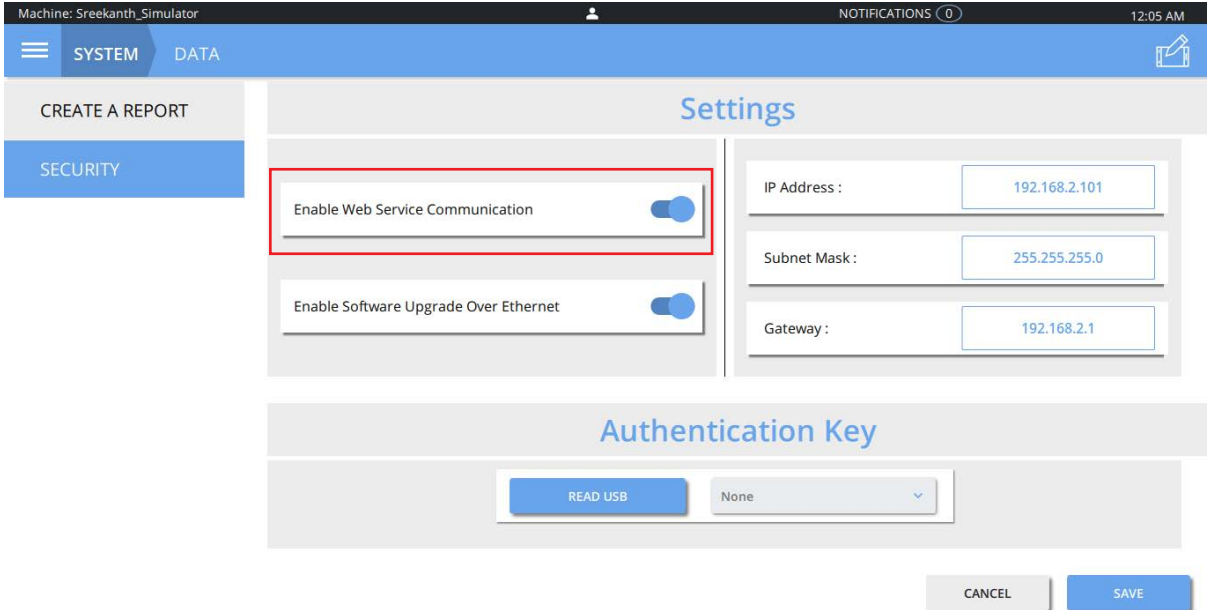

The screenshot displays the 'Settings' page in the Branson simulator. The left sidebar shows 'SYSTEM' and 'DATA' tabs, with 'SECURITY' selected. The main content area is titled 'Settings' and contains two sections: 'Settings' and 'Authentication Key'. In the 'Settings' section, the 'Enable Web Service Communication' toggle is turned on and is highlighted with a red rectangular box. Below it, the 'Enable Software Upgrade Over Ethernet' toggle is also turned on. To the right of these toggles are three input fields: 'IP Address' (192.168.2.101), 'Subnet Mask' (255.255.255.0), and 'Gateway' (192.168.2.1). The 'Authentication Key' section features a 'READ USB' button and a dropdown menu currently set to 'None'. At the bottom right of the settings area, there are 'CANCEL' and 'SAVE' buttons.

NOTICE	
	<p>Only executive level users can enable web service communication.</p>

D.3 Authentication Key

An authentication key consists on a 32 character alphanumeric sequence, and it is required to log in via web services.

Table D.1 Authentication Key



Step	Action
1	<p>On a PC, open Notepad and type: @BEGIN_KEY@<32 CHARACTERS ALPHANUMERIC SEQUENCE>@END_KEY@ Example: @BEGIN_KEY@1234567890QWERTYUIOPASDFGHJKLZXC@END_KEY@</p> 
2	<p>Open the <i>File</i> menu and press the <i>Save As...</i> button. On the dialog box, press the <i>Save as type:</i> menu and select <i>All Files</i>. Enter a name for the file without spaces and with a .key extension, e.g. NAME.key and save the file on the root of an empty USB memory stick.</p>  <p>NOTICE Do not use spaces in the file name.</p>
3	<p>Insert the USB memory stick into the USB port located on the power supply.</p> 

Table D.1 Authentication Key

Step	Action
4	<p>On the HMI, press the <i>Main Menu</i> button and navigate to <i>System > Data > Security</i>. Press the <i>Read USB</i> button and select the .key file that was previously created. Press the <i>Save</i> button to upload the authentication key into the GSX-E1 system.</p>  <p>The screenshot shows the 'Settings' page in the 'SECURITY' section. The 'Authentication Key' section is highlighted with a red box, containing a 'READ USB' button and a dropdown menu currently set to 'None'. Below this are 'CANCEL' and 'SAVE' buttons.</p>

NOTICE	
	<p>After uploading the Authentication Key, the system must be restarted.</p>

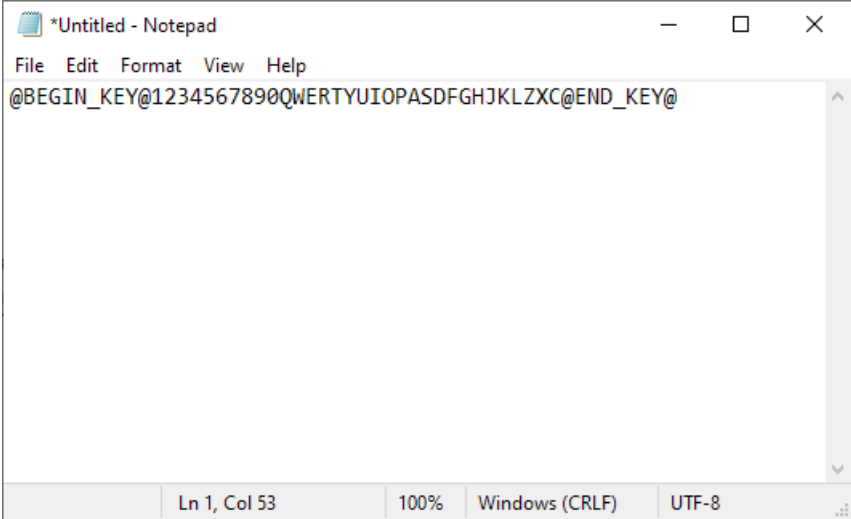
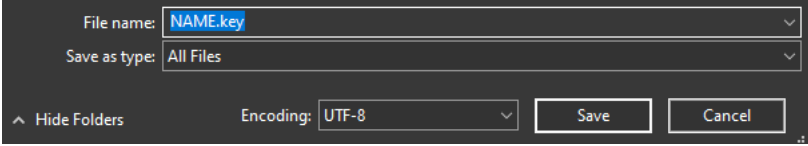
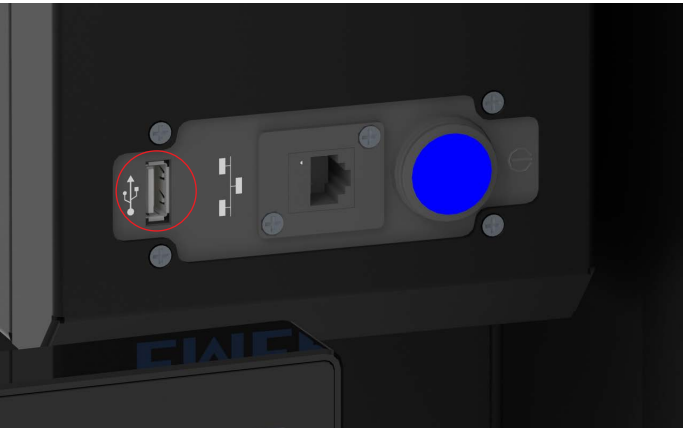
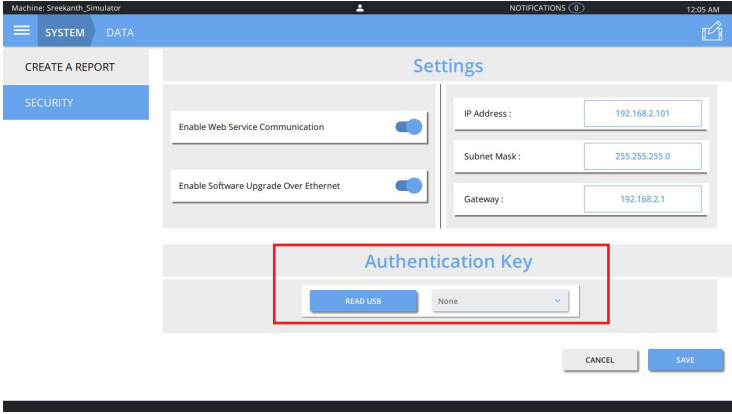
D.4 Command List

This section will define all the possible web requests that can be sent to the server. All URLs and accompanying POST Data is made available here.

Table D.2 Command List

Command List		
Login	Set Active Recipe	Get Last Weld Result
Logout	Set Recipe Value	Get Weld History
Get SW Version	Get Recipe Value	Get Number of Alarms
Delete Recipe	Get System Value	Get Alarm Log
Save Recipe	Get Number of Weld History	Get Graph Results

D.4.1 Login

- Login request will be accepted only if Authority Check is On during System Configuration
- Status Code 29 will be returned If Authority check is Off
- User must pass username, password and 2nd level authentication key
- 2nd level authentication key field will consist of the reversed 32 alphanumeric original sequence. See section [D.3 Authentication Key](#) for more information

Login service format:

URL

https://<GSX-E1 Ethernet IP Address>/Services/SystemLogin

POST Data

```
{"UserId":"XXXXX","Password":"XXXXX","Key":"Reversed 32 alphanumeric original sequence"}
```

Response

```
{"StatusCode":0,"Sid":12345}
```

- If login is successful, a unique ID will be written to Client. This will be used for future communications. This is called Session ID, "SID"
- All authority privileges for Executive, Supervisor, Operator and Technician should work as per the HMI functionality
- This session will remain for limited time as per "Idle Logoff Time" later it will be expired, which is set on the HMI UI
- Once the session expires, no indications will be shown in the web client; Status Code 2 will be returned on the next command, indicated that the session has expired
- After logging in, all requests needs to use the unique SID in the post command for validation, else Status Code 35 will be returned
- If log in fails due to an expired password, it will be indicated by Status Code 16
- Logging in to the system creates an event and will be stored in Event History

UI screens that restrict the Web Services user to log in

- System > Calibration
- System > Configuration > User Management > Modify User (only if the user being modified is the one trying to login through the Web Services)
- System > Configuration > User Authority > Operators Authority Options (only if the user that is trying to login is an operator)
- System > Configuration > Change Password (only if the UI user logged at that moment is the same trying to login through the Web Services)
- System > Data > Security
- Actuator Setupzz
- Actuator Setup > Advanced Feature

D.4.2 Logout

- The logout service is needed only when Authority check is to ON
- Logging out of the system creates an event that is stored in the Event History

Logout service format:

URL

https://<SC Ethernet IP Address>/Services/SystemLogout

POST Data

```
{"Sid":12345}
```

Response

```
{"StatusCode":0}
```

- SID is required for logout function so if it is lost then user must wait for idle logout time

D.4.3 Get SW Version

- This is used to get all software versions running inside Machine as SC, AC, PC and UI
- UI Version will be shown if HMI is Open, else NA will be returned with Status Code 32

Get SW Version service format:

URL

https://<SC Ethernet IP Address>/Services/GetSoftwareVersion

POST Data

```
{"Sid":12345}
```

Response

```
{"StatusCode":0,
```

```
"Supervisory
```

```
"Actuator
```

```
"Power
```

```
"HMI Controller","1.2.0.0"}

```

```
Controller","1.2.0.0",
Controller","1.2.0.0",
Controller","1.2.0.0",

```

D.4.4 Delete Recipe

- This service will delete a recipe
- The recipe must not be an active recipe
- The rules for deleting a recipe will follow User Authority policy

Delete Recipe service format:

URL

https://<Ethernet IP Address>/Services/DeleteRecipe

POST Data

```
{"Sid":12345,"RecipeNo":2}
```

Response

```
{"StatusCode":0}
```

D.4.5 Save Recipe

- This service will save current recipe

Save Recipe service format:

URL

https://<Ethernet IP Address>/Services/SaveCurrentRecipe

POST Data

```
{"Sid": 12345}
```

Response

```
{"StatusCode":0}
```

D.4.6 Set Active Recipe

- This service will set a recipe to active state
- The recipe will become recipe zero (current recipe)
- If Current Active recipe is not in saved mode then Status Code 33 will be returned
- If provided recipe number is not available Status Code 28 will be returned
- The rules for setting a recipe active will follow User Authority policy

Set Active Recipe service format:

URL

https://<Ethernet IP Address>/Services/SetActiveRecipe

POST Data

```
{"Sid": 12345, "RecipeNo": 24}
```

Response

```
{"StatusCode":0, "RecipeNo":24}
```

D.4.7 Set Recipe Value

- This service will set a recipe parameter value(s) in a recipe
- Recipe zero will be updated if recipe is active
- The rules for setting a recipe value will follow User Authority policy

To set single recipe value:

URL

https://<Ethernet IP Address>/Services/SetRecipeValue

POST Data

```
{"Sid":12345,"ParamId":28,"ParamValue":50,"Reason":"xyz"}
```

Response

```
{"StatusCode":0}
```

To set multiple recipe values:

URL

https://<Ethernet IP Address>/Services/SetRecipeValue

POST Data

```
{"Sid":12345, "RecipeValues":[{"ParamId":28,"ParamValue":50}, {"ParamId":29,"ParamValue":75}] "Reason":"xyz"}
```

Response

```
{"StatusCode":0}
```

D.4.8 Get Recipe Value

- This service will return a recipe parameter value(s) from a recipe
- The rules for getting a recipe value will follow User Authority policy

To get single recipe value:

URL

https://<Ethernet IP Address>/Services/GetRecipeParamValue

POST Data

```
{"Sid":12345,"ParamId":28}
```

Response

```
{"StatusCode":0,"ParamId":28,"ParamValue":50}
```

To get multiple recipe values:

URL

https://<Ethernet IP Address>/Services/GetRecipeParamValue

POST Data

```
{"Sid":12345,"RecipeParameters":[{"ParamId":28}, {"ParamId":29}]}
```

Response

```
{"StatusCode":0,"RecipeParameters":[{"ParamId":28,"ParamValue":50}, {"ParamId":29,"ParamValue":75}]}
```

NOTICE



There is a maximum web service request size of 512 bytes. This applies to the entire packet size, not just the POST data. This limitation means that the entire recipe cannot be sent in one request, but must be broken up into multiple requests.

Similarly, the request to read the entire recipe must also be broken up into multiple requests.

D.4.8.1 Recipe Parameter ID

Table D.3 Recipe Parameter ID

ID	Name	Unit
1	WELD_MODE	Coded See Table D.4 Weld Mode
2	MODE_VALUE	Dependant See Table D.5 Mode Value
3	AMPLITUDESTEPSCNT	N/A
4	AMPLITUDE_STEP_AT	Coded See Table D.6 Amplitude Step At
5	AMPLITUDE_STEP_VALUE1	Dependant See Table D.7 Amplitude Step Value (1-10)
6	AMPLITUDE_STEP_VALUE2	
7	AMPLITUDE_STEP_VALUE3	
8	AMPLITUDE_STEP_VALUE4	
9	AMPLITUDE_STEP_VALUE5	
10	AMPLITUDE_STEP_VALUE6	
11	AMPLITUDE_STEP_VALUE7	
12	AMPLITUDE_STEP_VALUE8	
13	AMPLITUDE_STEP_VALUE9	
14	AMPLITUDE_STEP_VALUE10	
15	AMPLITUDE_STEP1	%
16	AMPLITUDE_STEP2	%
17	AMPLITUDE_STEP3	%
18	AMPLITUDE_STEP4	%
19	AMPLITUDE_STEP5	%
20	AMPLITUDE_STEP6	%
21	AMPLITUDE_STEP7	%
22	AMPLITUDE_STEP8	%
23	AMPLITUDE_STEP9	%
24	AMPLITUDE_STEP10	%
25	TRIGGER_FORCE	N
26	NUM_FORCE_STEPS	N/A
27	FORCE_STEP_AT	Coded See Table D.8 Force Step At
28	FORCE_STEP1	N
29	FORCE_STEP2	N
30	FORCE_STEP3	N

Table D.3 Recipe Parameter ID

ID	Name	Unit
31	FORCE_STEP4	N
32	FORCE_STEP5	N
33	FORCE_STEP6	N
34	FORCE_STEP7	N
35	FORCE_STEP8	N
36	FORCE_STEP9	N
37	FORCE_STEP10	N
38	HOLD_TIME	s
39	PRETRIGGER	ON/OFF
40	AUTO_PRETRIGGER	ON/OFF
41	DISTANCE_PRETRIGGER	NOTICE Auto Pretrigger and Distance Pretrigger can't be ON at the same time.
42	PRETRIGGER_AMPLITUDE	%
43	PRETRIGGER_DISTANCE	mm
57	GLOBALSUSPECT	ON/OFF
58	GLOBALREJECT	ON/OFF
59	SUSPECT_TIME_ENABLED	ON/OFF
60	SUSPECT_TIME_LOW_VALUE	s
61	SUSPECT_TIME_HIGH_VALUE	s
62	REJECT_TIME_ENABLED	ON/OFF
63	REJECT_TIME_LOW_VALUE	s
64	REJECT_TIME_HIGH_VALUE	s
65	SUSPECT_ENERGY_ENABLED	ON/OFF
66	SUSPECT_ENERGY_LOW_VALUE	J
67	SUSPECT_ENERGY_HIGH_VALUE	J
68	REJECT_ENERGY_ENABLED	ON/OFF
69	REJECT_ENERGY_LOW_VALUE	J
70	REJECT_ENERGY_HIGH_VALUE	J
71	SUSPECT_PEAKPOWER_ENABLED	ON/OFF
72	SUSPECT_PEAKPOWER_LOW_VALUE	W
73	SUSPECT_PEAKPOWER_HIGH_VALUE	W
74	REJECT_PEAKPOWER_ENABLED	ON/OFF
75	REJECT_PEAKPOWER_LOW_VALUE	W
76	REJECT_PEAKPOWER_HIGH_VALUE	W
77	SUSPECT_ABSOLUTEDISTANCE_ENABLED	ON/OFF

Table D.3 Recipe Parameter ID

ID	Name	Unit
78	SUSPECT_ABSOLUTEDISTANCE_LOW_VALUE	mm
79	SUSPECT_ABSOLUTEDISTANCE_HIGH_VALUE	mm
80	REJECT_ABSOLUTEDISTANCE_ENABLED	ON/OFF
81	REJECT_ABSOLUTEDISTANCE_LOW_VALUE	mm
82	REJECT_ABSOLUTEDISTANCE_HIGH_VALUE	mm
83	SUSPECT_COLLAPSEDISTANCE_ENABLED	ON/OFF
84	SUSPECT_COLLAPSEDISTANCE_LOW_VALUE	mm
85	SUSPECT_COLLAPSEDISTANCE_HIGH_VALUE	mm
86	REJECT_COLLAPSEDISTANCE_ENABLED	ON/OFF
87	REJECT_COLLAPSEDISTANCE_LOW_VALUE	mm
88	REJECT_COLLAPSEDISTANCE_HIGH_VALUE	mm
89	SUSPECT_TRIGGERDISTANCE_ENABLE	ON/OFF
90	SUSPECT_TRIGGERDISTANCE_LOW_VALUE	mm
91	SUSPECT_TRIGGERDISTANCE_HIGH_VALUE	mm
92	REJECT_TRIGGERDISTANCE_ENABLE	ON/OFF
93	REJECT_TRIGGERDISTANCE_LOW_VALUE	mm
94	REJECT_TRIGGERDISTANCE_HIGH_VALUE	mm
95	SUSPECT_ENDWELDFORCE_ENABLED	ON/OFF
96	SUSPECT_ENDWELDFORCE_LOW_VALUE	N
97	SUSPECT_ENDWELDFORCE_HIGH_VALUE	N
98	REJECT_ENDWELDFORCE_ENABLED	ON/OFF
99	REJECT_ENDWELDFORCE_LOW_VALUE	N
100	REJECT_ENDWELDFORCE_HIGH_VALUE	N
101	SUSPECT_FREQUENCY_ENABLED	ON/OFF
102	SUSPECT_FREQUENCY_LOW_VALUE	Hz
103	SUSPECT_FREQUENCY_HIGH_VALUE	Hz
104	REJECT_FREQUENCY_ENABLED	ON/OFF
105	REJECT_FREQUENCY_LOW_VALUE	Hz
106	REJECT_FREQUENCY_HIGH_VALUE	Hz
123	FORCE_STEP_VALUE1	Dependant See Table D.9 Force Step Value (1-10)
124	FORCE_STEP_VALUE2	
125	FORCE_STEP_VALUE3	
126	FORCE_STEP_VALUE4	
127	FORCE_STEP_VALUE5	
128	FORCE_STEP_VALUE6	
129	FORCE_STEP_VALUE7	

Table D.3 Recipe Parameter ID

ID	Name	Unit
130	FORCE_STEP_VALUE8	Dependant See Table D.9 Force Step Value (1-10)
131	FORCE_STEP_VALUE9	
132	FORCE_STEP_VALUE10	
133	FORCE_STEP_RAMP_VALUE1	s
134	FORCE_STEP_RAMP_VALUE2	s
135	FORCE_STEP_RAMP_VALUE3	s
136	FORCE_STEP_RAMP_VALUE4	s
137	FORCE_STEP_RAMP_VALUE5	s
138	FORCE_STEP_RAMP_VALUE6	s
139	FORCE_STEP_RAMP_VALUE7	s
140	FORCE_STEP_RAMP_VALUE8	s
141	FORCE_STEP_RAMP_VALUE9	s
142	FORCE_STEP_RAMP_VALUE10	s
143	FORCE_RAMP_TIME	s
144	HOLD_FORCE	N
145	HOLD_FORCE_RAMP_TIME	s
146	READY_POSITION	mm
148	READY_POSITION_TOGGLE	ON/OFF
149	EXPECTED_PART_CONTACT_POSITION	mm
150	PART_CONTACT_WINDOW_OFFSET	mm
151	PART_CONTACT_WINDOW_MINUS	mm
152	PART_CONTACT_WINDOW_PLUS	mm
153	DOWN_ACCELERATION	mm/s ²
154*	DOWN_MAX_VELOCITY	mm/s
155	DOWN_DECELERATION	mm/s ²
156	RETURN_ACCELERATION	mm/s ²
157*	RETURN_MAX_VELOCITY	mm/s
158	RETURN_DECELERATION	mm/s ²
159	WELD_RAMP_TIME	s

NOTICE

*When setting these values, input must be divided by 1000 (in order to set a value of 50, need to send 50000). Similarly, when reading back the values, multiply the results by 1000.

D.4.8.2 Coded Recipe Parameters

Table D.4 Weld Mode

Value ID	Name	Value ID	Name
1	Time	5	Absolute Distance
2	Energy	6	Collapse Distance
3	Peak Power	7	Dynamic
4	Ground Detect		

Table D.5 Mode Value

Value ID	Name	Value ID	Name
Time	s	Absolute Distance	mm
Energy	J	Collapse Distance	mm
Peak Power	W	Dynamic	%
Ground Detect	s		

Table D.6 Amplitude Step At

Value ID	Name	Value ID	Name
1	Time	4	Absolute Distance
2	Energy	5	Collapse Distance
3	Peak Power	6	External Signal

Table D.7 Amplitude Step Value (1-10)

If Amplitude Step At is:	Amplitude Step Value 1-10 unit is:
Time	s
Energy	J
Peak Power	W
Absolute Distance	mm
Collapse Distance	mm
External Signal	Just 1 amplitude step, no unit

Table D.8 Force Step At

Value ID	Name	Value ID	Name
1	Time	4	Absolute Distance
2	Energy	5	Collapse Distance
3	Peak Power	6	External Signal

Table D.9 Force Step Value (1-10)

If Force Step At is:	Force Step Value 1-10 unit is:
Time	s
Energy	J
Peak Power	W
Absolute Distance	mm
Collapse Distance	mm
External Signal	Just 1 force step, no unit

D.4.9 Get System Value

- This service will return a system parameter value from the system configuration information

Get System Value service format:

URL

https://<Ethernet IP Address>/Services/GetSystemConfigValue

POST Data

```
{"Sid": 12345, "ParamId": 2}
```

Response

```
{"StatusCode": 0, "ParamValue": 1}
```

Or

```
{"StatusCode": 0, "ParamValue": "xyz"}
```

D.4.9.1 Parameter ID and Values

Table D.10 Parameter ID and Values

ID	Name
1	Memory Full Action
	STOP: 0
	CONTINUE: 1
2	Language
	ENGLISH: 0
	FRENCH: 1
	SPANISH: 2
	GERMAN: 3
	KOREAN: 4
	TRADITIONAL CHINESE: 5
	SIMPLIFIED CHINESE: 6
	ITALIAN: 7
JAPANESE: 8	
3	Start Up Screen
	DASHBOARD: 0
	PRODUCTION: 1
	RECIPES: 2
4	Recipe Prefix for Barcode Scan
	Any letter representing the prefix of the recipe number. R is default
5	Part ID Switch Status
	OFF: 0
	ON: 1

Table D.10 Parameter ID and Values

ID	Name
8	Power Supply Power Up Option
	SEEK: 0
	SCAN: 1
9	NONE: 2
	Machine Name
	FLOOR 1

D.4.10 Get Number of Weld History

- This service will return the total number of welds results currently available in the DB for the current active recipe

Get Number of Weld History service format:

URL

https://<Ethernet IP Address>/Services/GetNumWeldData

POST Data

```
{"Sid":12345}
```

Response

```
{"StatusCode":0,"TotalWeldDataPresent":200}
```

D.4.11 Get Last Weld Result

- This service is used to get weld result after every weld
- Using this service, Ready signal should trigger the most recent weld result

Get Last Weld Result service format:

URL

`https://<Ethernet IP Address>/Services/GetWeldResult`

POST Data

```
{"Sid":12345}
```

Response

```
{"StatusCode":0,  
"1":Value,  
"2":Value,  
...  
"29":Value}
```

NOTICE



Weld data is in JSON format.

D.4.11.1 Weld Results ID

Figure D.3 Weld Results ID

ID	Name	Unit
1	Recipe Number	N/A
2	Recipe Version Number	N/A
3	Date and Time of Weld	N/A
4	Stack Serial Number	N/A
5	Cycle Counter	N/A
6	Weld Mode	Coded See Table D.11 Weld Mode
7	Max Weld Force	N
8	End Hold Force	N
9	Weld Absolute	µm
10	Total Absolute	µm
11	Weld Collapse Distance	µm
12	Hold Collapse Distance	µm
13	Total Collapse Distance	µm
14	Trigger Distance	µm
15	Velocity	µm/s
16	Weld Time	ms
17	Weld Energy	dJ
18	Weld Peak Power	W
19	Start Frequency	Hz
20	Frequency Change	Hz
21	Cycle Time	ms
22	Username	N/A
23	Part ID	N/A
24	Batch ID	N/A
25	Trigger start Point	ms
26	Weld Start Point	ms
27	Hold Start Point	ms
28	Alarm Flag	N/A
29	Recipe Status	Coded See Table D.12 Recipe Status

D.4.11.2 Coded Weld Results

Table D.11 Weld Mode

Value ID	Name
1	Time
2	Energy
3	Peak Power
4	Ground Detect
5	Absolute Distance
6	Collapse Distance
7	Dynamic

Table D.12 Recipe Status

Value ID	Name
0	Saved
1	Validated
2	Unsaved
3	Invalidated

D.4.12 Get Weld History

- If the request is for more than 50, then only 50 will be returned starting at the "from" value
- If the request is for more than the values stored in the system, it will only return the actual amount of results in the system
- The results will be returned for the current Active recipe only
- These two fields are index to the array of welds stored in the memory; their difference should not exceed 50
- If both from and to are zero, then latest 50 will returned

Get Weld History service format:

URL

https://<Ethernet IP Address>/Services/GetWeldHistory

POST Data

```
{"Sid":12345,"From":120,"To":169}
```

Response

```
{"StatusCode":0,  
"WeldData":[  
{"1":Value,"2":Value,...,"29":Value},  
{"1":Value,"2":Value,...,"29":Value},  
...  
{"1":Value,"2":Value,...,"29":Value}]}
```

D.4.13 Get Number of Alarms

- This web service request will return the number of alarms available in the database

Get Number of Alarms service format:

URL

https://<Ethernet IP Address>/Services/GetNumAlarms

POST Data

```
{"Sid": 12345}
```

Response

```
{"StatusCode":0,"TotalAlarmPresent":200}
```

D.4.14 Get Alarm Log

- This web service request will return the alarms available in the DB from the range provided as the input
- There are two ways to get alarm data:
 - Get the most recent 50 alarms. This will contain "from" and "to" values to 0
 - Get any random chunk of up to 50 alarms
- These two fields are index to the array of welds stored in the memory; their difference should not exceed 50

Get Alarm Log service format:

URL

https://<Ethernet IP Address>/Services/GetAlarmLogData

POST Data

Most recent 50 alarms

```
{"Sid": 12345,"From":0,"To":0}
```

Random chunk of up to 50 alarms

```
{"Sid": 12345,"From":120,"To":169}
```

Response

```
{"StatusCode":0,
"AlarmData":[
{"1":Value,"2":Value,...,"6":Value},
{"1":Value,"2":Value,...,"6":Value},
...
{"1":Value,"2":Value,...,"6":Value}]}
```

D.4.14.1 Parameter ID

Table D.13 Parameter ID

ID	Name
1	Date and Time
2	Recipe Number
3	Recipe Ver Number
4	Alarm ID
5	Username
6	Cycle Counter

D.4.15 Get Graph Results

- This service will return the graph data of the particular result mentioned by recipe number and cycle counter.

Get Graph Results service format:

URL

https://<Ethernet IP Address >/Services/GetGraphResult

POST Data

```
{"Sid":12345,"CycleCounter":1,"RecipeNo":1}
```

Response

```
{"StatusCode":0,
"RecipeNo":Recipe #,"RecipeVerNum":Recipe Version #,"Cycle":Cycle #,
"Time":[Time 0, ... ,Time n],"Frequency":[Frequency 0, ... ,Frequency n],"Power":[Power 0, ... ,Power
n],"Current":[Current 0, ... ,Current n],"Amplitude":[Amplitude 0, ... ,Amplitude n], "Phase":[Phase 0, ...
,Phase n], "Energy":[Energy 0, ... ,Energy n],"Force":[Force 0, ... ,Force n],"Velocity":[Velocity 0, ... ,Velocity
n],"AbsDistance":[AbsDistance 0, ... ,AbsDistance n],"ColDistance":[ColDistance 0, ... ,ColDistance n]}
```

D.5 HTTPS Support

- User must connect to SC Ethernet using HTTPS protocol only
- A Default Certificate available in the server side (RTP_SC) will be shared with the client on the successful connection to use it for future communications from the client
- SSL Certificate expiry notifications should be given to the user from HMI UI with 6 Months, 1 month and 1 day as the limits
- If certificate expires and a HTTP request is received, server should respond accordingly using built in HTTP errors for invalid certificate

D.5.1 HTTPS and Status Codes

Information Responses

- TBD

Successful Responses

- **200** **OK**
The request has succeeded
- **202** **Accepted**
The request has been received but not yet acted upon

Client Error Responses

- **400** **Bad Request**
Server could not understand the request due to invalid syntax
- **401** **Unauthorized**
Client must authenticate itself to get the requested response
- **403** **Forbidden**
Client does not have access rights to the content
- **404** **Not Found**
Server cannot find requested resource
- **413** **Request Buffer Too Large**
Maximum web service request size of 512 bytes reached

Server Error Responses

- **500 Internal Server Error**
- **501** **Not Supported**
Request method is not supported by the server (service)
- **503 Service Unavailable**

Table D.14 Server Error Responses

ID	Error	Description
0	SUCCESS	Command executed success
1	ALREADY_LOGGED_IN	Another user is already logged in via HMI/web services
2	NOT_LOGGED_IN	Tried to executed a Command without login
3	WRONGNAME_PASSWORD	Invalid username or password provided for login command
4	FIRSTTIMELOGIN	User is trying to login for the first time. A first time login after the user creation is not permitted in the web services. The user must use the HMI to login and need to change the password later he can login via web services
5	RECIPE_NOT_VERIFIED	

Table D.14 Server Error Responses

ID	Error	Description
6	SYSTEM_BUSY	Internally if any of the message queue response is not recipe with in 5 sec then this error will be sent to client
7	EXCEEDS_LIMITS	Recipe parameter provided is not in the range
8	MISMATCH_PARAMID	Parameter ID provided is either not available or the runtime features flag is off for this parameter
9	DATA_NOT_FOUND_IN_SPECIFIEDRANGE	Parameter value provides is Invalid or not in the range.
10	EXCEEDS_ACTIVEUSER	While creating a new user, if existing Active users count exceeds the maximum Active Users limit
11	EXCEEDS_TOTALUSER	While creating a new user, if existing users count exceeds the maximum limit
12	INVALID_PASSWORD	While creating a new user, the provided password is not valid
13	LARGENO_OF_DATA_REQUESTED	
14	USERID_CHANGE_NOT_PERMITTED	
15	INVALID_SECURITYLEVEL	Logged in user don't have privileges to perform the provided command
16	PASSWORDEXPIRED	While user tried to login, if password was expired this error will come. User need to use HMI to change the new password and need to retry in web services with new password.
17	USEREXIST	While creating a new user, the user ID provided is already exists
18	MAXWRONGATTEMPTS	User attempts Login with same user ID and password for 5 times wrongly
19	SBC_CONNECTION_TIMEOUT	
20	REASON_REQUIRED	Reason not provided while modifying the recipe parameter value
21	RECIPE_NOT_ENABLED	
22	INVALID_SERVICE_DATA	If SID is wrong or the command provided is not supported then this error code will be sent
23	INVALID_JSON_FORMAT	The JSON format came from the web client is wrong
24	AUTOMATION_ENABLED	
25	SBC_DATA_TIMEOUT	
26	INVALID_USERIO_INPUT	In User IO command, the provided input is not valid
27	INVALID_ACTUATOR_FOR_USERIO_INPUT	In User IO command, the provided actuator input is not valid
28	RECIPE_NOT_FOUND	The recipe number is not available in DB which was a provided in the command set active recipe
29	AUTHORITY_CHECK_DISABLED	User can't login via web services if Authority check was disable via HMI
30	INVALID_CLIENT	
31	NOT_SUPPORTED	Toggle button is off in data screen

Table D.14 Server Error Responses

ID	Error	Description
32	UI_NOT_CONNECTED	UI is not connected to SC, this error code will be sent on get software version only as UI version is sent as NA
33	ACTIVE_RECIPE_NOT_SAVED	set active recipe command is performed without saving current active recipe
34	MEMORY_FULL_ALARM	No Memory in the DB
35	USER_ACCOUNT_DISABLED	The user account was disabled which was provided in login command
36	DELETE_RECIPE_FAIL_ACTIVE_RECIPE	Recipe number provided in delete recipe is Active Recipe, So Can't be deleted.
37	INVALID_UI_SCREEN	The UI screen page does not allow the WebServices user to login, please change the screen page.

Appendix E: EtherNet/IP

E.1	GSX-E1 EtherNet/IP	238
------------	---------------------------------	------------

E.1 GSX-E1 EtherNet/IP

NOTICE



See document **BU-4001304 GSX-E1 EtherNet/IP User Guide** for more information.

Appendix F: Frequently Asked Questions

F.1 **Frequently Asked Questions240**

F.1 Frequently Asked Questions

F.1.1 How do I turn on a GSX-E1 system?

After the GSX-E1 is installed, press the power button located on the front of the power supply. The GSX-E1 system will go through its normal turn on sequence. At the end of this sequence, the Login screen will be displayed.

Figure F.1 Power button on the GSX-E1 system

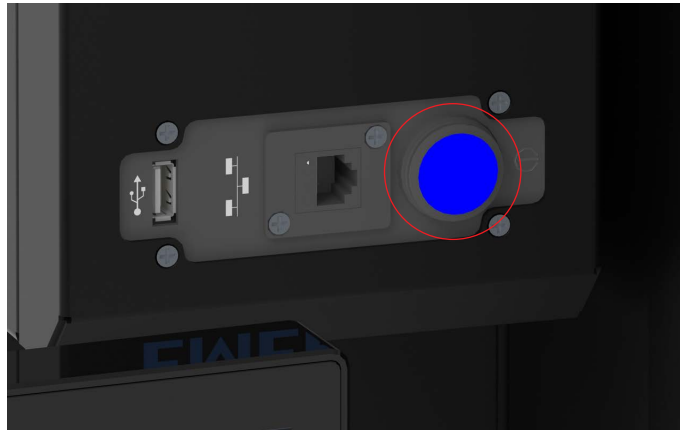

Figure F.2 Power button on the GSX-E1 EtherNet/IP system



F.1.2 Where can I find the GSX-E1 system details?

You can view details and information about the current setup of your GSX-E1 system from the *Machine Details* screen in the System menu.

See section [5.10.5 Information](#) for details.

Figure F.3 Machine Details

Machine: UW-M/C-NAME ADMIN NOTIFICATIONS 05:48 AM

SYSTEM INFORMATION

Machine Details Event Log

Model General Alarm

Software Versions

UI Controller Supervisory Controller

Actuator Controller Power Controller

SOFTWARE UPGRADE

Power Supply

Life Time Welds Overloads

PS Type PS Frequency

PS Watt

Actuator

Life time cycles Type

Calibration Date Overloads

Stroke Length

Connectivity

MAC ID

Third Party Software Information

Please refer to the following URL for information about third party software (e.g., open source software) used in this product: <https://www.emerson.com/documents/automation/open-source-software-notice-en-us-5317230.pdf>

F.1.3 How do I set up a new welding application with recipes using a GSX-E1 system?

You can set up the GSX-E1 system to weld a particular application and then save the settings to a recipe. After analyzing your specific application, you can determine the Weld Mode to use to weld your parts. There are six Weld Modes to choose from Time, Energy, Peak Power, Ground Detect, Absolute Distance and Collapse Distance.

The following table describes each mode:

Mode	Description
Time	Use Time mode to select the length of time (in seconds) that ultrasonic energy is applied to your parts. Within Time mode, you can also select several other parameters, ranging from Hold Time (in seconds) to Suspect and Reject Limits.
Energy	Use Energy mode to select the amount of ultrasonic energy (in joules) that is applied to your parts. Within Energy mode, you can also select several other parameters, ranging from Hold Time (in seconds) to Suspect and Reject Limits.
Peak Power	Use Peak Power mode to select the maximum watts of the total available power that will be used to process your welds. When the power level you set is reached, ultrasonics will be terminated. From within Peak Power Mode, you can also select several other parameters, ranging from Hold Time (in seconds) to Suspect and Reject Limits.
Ground Detect	Use Ground Detect mode to have ultrasonic energy turn off when the horn comes in contact with your electrically isolated fixture or anvil. The electrically isolated fixture should be so designed that the insulator allows no continuity to the actuator base. It is necessary to install Ground Detect cable (see Table 6.14 for more information) from the connector on the side of the actuator to your isolated fixture/anvil in order to utilize this feature. From within Ground Detect Mode, you can also select several other parameters, ranging from Hold Time (in seconds) to Suspect and Reject Limits.
Absolute Distance	You can use the Absolute Distance Mode to select the distance (in inches or millimeters) the horn will travel before ultrasonic energy is terminated. Within Absolute Mode, you can also select several other parameters ranging from Hold Time (in seconds) to Suspect and Reject limits.
Collapse Distance	You can use the Collapse Distance Mode to select the distance (in inches or millimeters) your part will be collapsed before ultrasonic energy is terminated. This distance parameter can be set when in Collapse Mode to establish Suspect and Reject Limits. Total Collapse Limits in Collapse Mode is that value achieved at the end of Hold. Within Collapse Mode, you can also select several other parameters, ranging from Hold Time (in seconds) to Suspect and Reject limits.

See section [5.7 Recipes](#) for details.

F.1.4 What are best practices to ensure proper maintenance of a GSX-E1 system?

Proper maintenance of the GSX-E1 system consists in periodically cleaning the equipment (covers and touchscreen), and reconditioning the stack (Converter, Booster and Horn).

NOTICE	
	There are no customer replaceable components inside the system. Have all servicing done by a qualified Branson technician.

See [Chapter 6: Maintenance](#) for details.

F.1.5 How do I service a GSX-E1 system?

There are no customer replaceable components inside the system. Have all servicing done by a qualified Branson technician.

See section [7.2 How to Contact Branson](#) to find information on how to contact Branson Service Specialists to help you address your servicing needs.

F.1.6 What is the OS of the GSX-E1 system?

The GSX-E1 system uses Windows 10.

F.1.7 What accessories and spare parts are applicable to the GSX-E1 system?

For a complete list of accessories and spare parts, see section [6.5 GSX-E1 Systems, Accessories, Spare Parts & Options](#).

F.1.8 How do I change or update my GSX-E1 system authority level?

User Authority ensures that users logging into the GSX-E1 system only have access to features dependent on their authority level. See section [5.10.1.4 User Authority](#) for details.

F.1.9 I'm struggling to find a specific GSX-E1 HMI icon and understand its functionality?

For detailed information on the HMI screen layout, see section [5.2 Screen Layout](#).

Figure F.4 Screen Layout

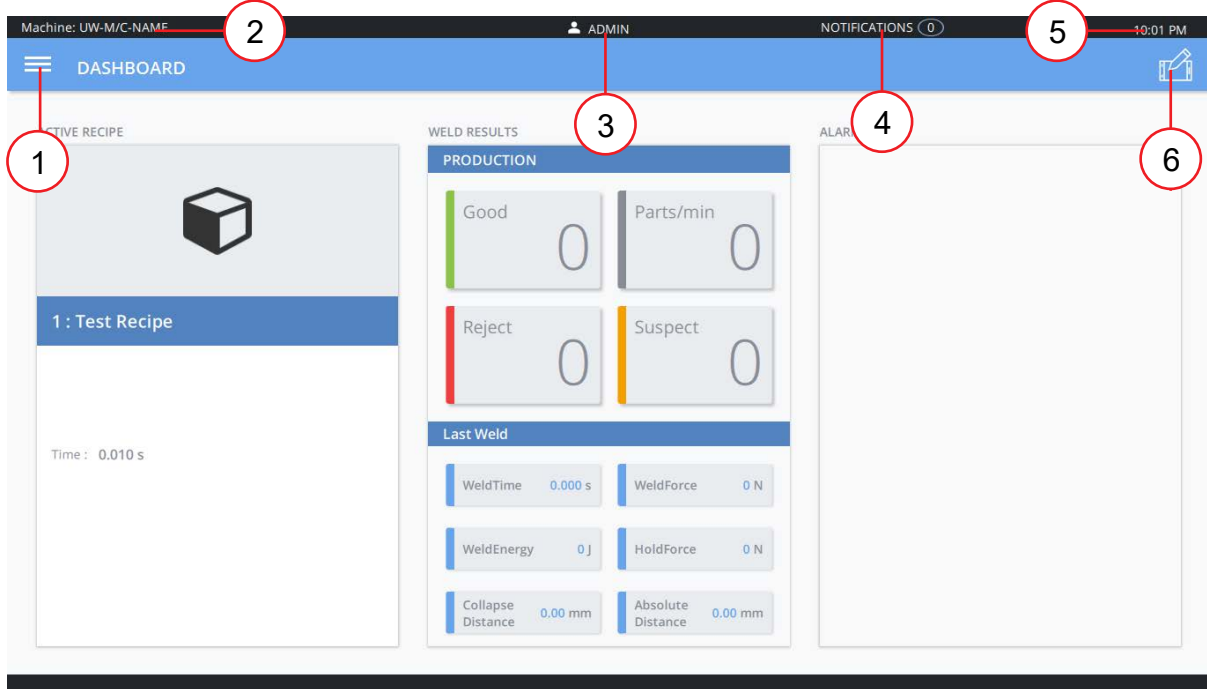

Item	Description
1	Main Menu Button Press the main menu button on the top left corner to open the Main Menu.
2	Machine Name Displays the assigned machine name.
3	Current User Displays the current user logged in.
4	Notifications Notifications alert you to the arrival of alarms and events.
5	Time Displays the current time.
6	Action Center Button Press the button on the top right corner to open the Action Center.

F.1.10 My GSX-E1 system is displaying an alarm. What does it mean and what do I do?

When the GSX-E1 system encounters a situation that is outside of normal conditions, an alarm is generated. If there is any alarm condition, the HMI displays the name of the alarm and a brief description. Press the Reset button to clear the alarm. See [Appendix A: Alarms](#) for more details.

Figure F.5 Alarm

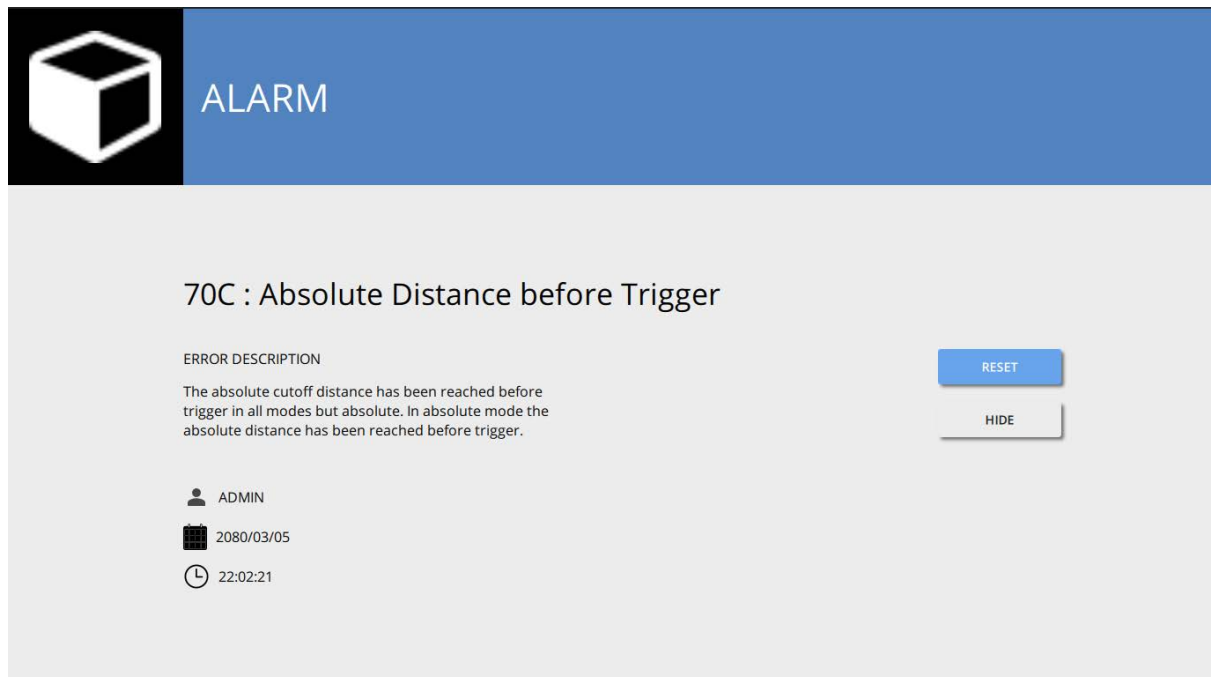

F.1.11 How do I connect an external device (keyboard, mouse, USB memory stick) to the GSX-E1 system?

USB (Universal Serial Bus) is a plug-and-play interface that allows the GSX-E1 system to communicate with keyboards and mice.

The GSX-E1 system is equipped with two USB ports located on the touchscreen.

Figure F.6 USB Ports

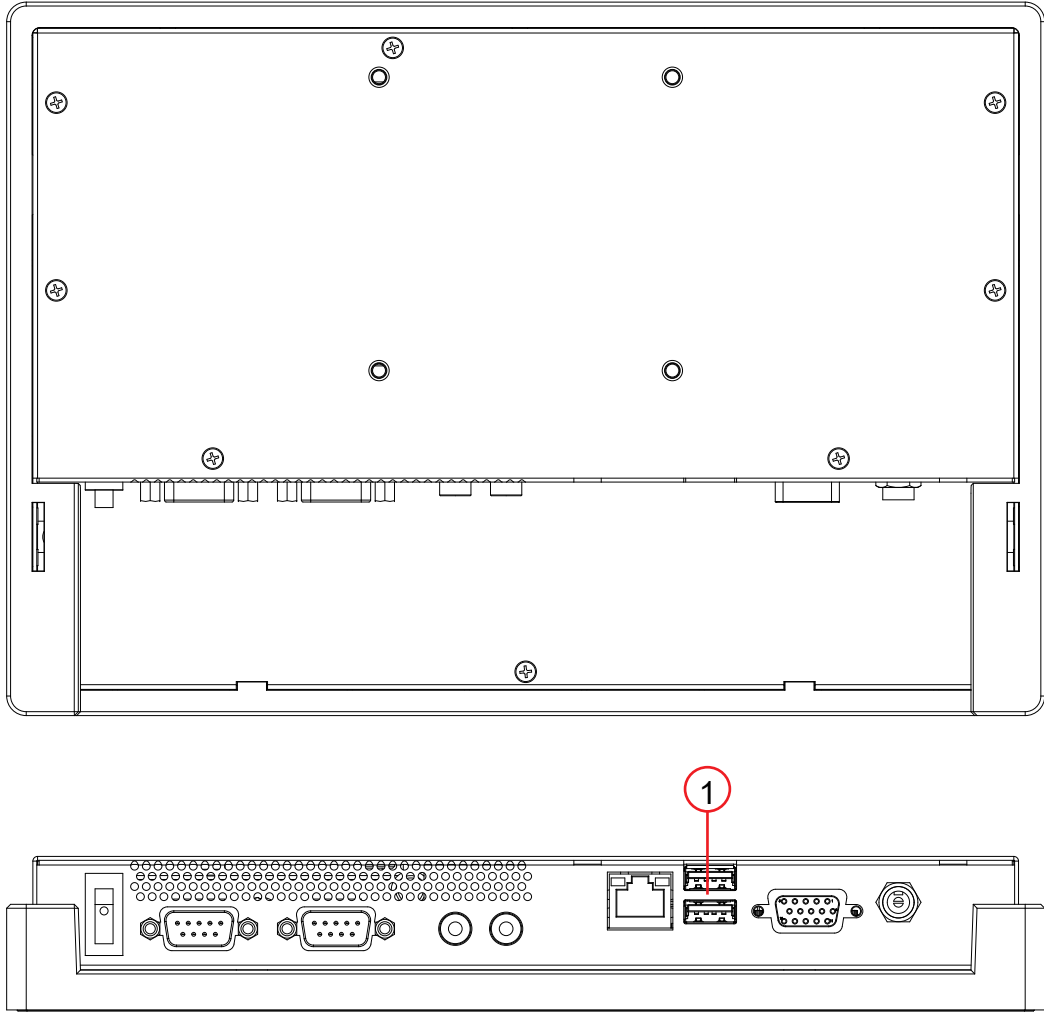

Table F.1 USB Ports

Item	Description
1	USB 2.0/USB 3.0 Ports

NOTICE



USB ports on the HMI are for keyboards and mice only. Do not use any other kind of device into these ports.

F.1.12 How do I connect a barcode scanner the GSX-E1 system?

The GSX-E1 system supports USB barcode scanners. The barcode scanner must have a keyboard emulation mode. The barcode scanner can be used to recall recipes and enter the Part ID by scanning 1D linear barcodes (such as UPC and EAN codes) & 2D barcodes (such as QR and Data Matrix codes). See section [5.10.1.1 General](#) for more information.

A Datalogic Gryphon I GD44XX barcode scanner is recommended for proper operation.

Figure F.7 Barcode scanner, 1D linear barcode & 2D barcode example



NOTICE	
	Barcode scanner must be connected to the USB port located on the power supply.

Figure F.8 Power Supply - USB port on the GSX-E1 system



Table F.2 Power Supply - USB port on the GSX-E1 system

Item	Description
1	USB 2.0/USB 3.0 Port

Figure F.9 Power Supply - USB port on the GSX-E1 EtherNet/IP system



Table F.3 Power Supply - USB port on the GSX-E1 EtherNet/IP system

Item	Description
1	USB 2.0/USB 3.0 Port

[This page intentionally left blank]

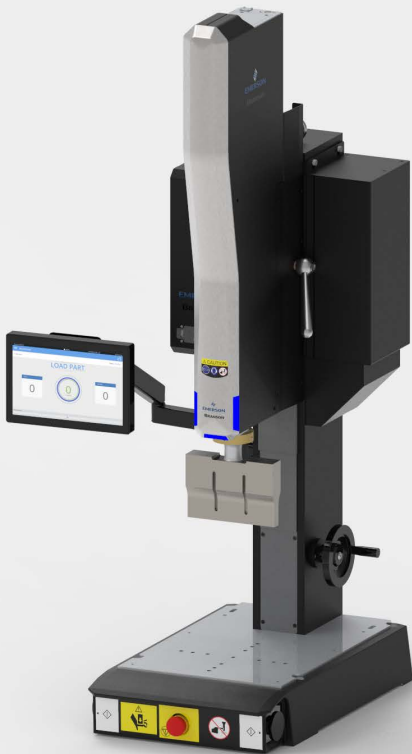

Branson Ultrasonics Corporation

120 Park Ridge Road
Brookfield, CT 06804
(203) 796-0400

<http://www.bransonultrasonics.com>

Copyright © 2025 Branson Ultrasonics Corporation. All rights reserved. Contents of this publication may not be reproduced in any form without the written permission of Branson Ultrasonics Corporation.

BRANSON